

BodyCraft

Family **Xpress** PRO STRENGTH TRAINING SYSTEM INSTRUCTION MANUAL

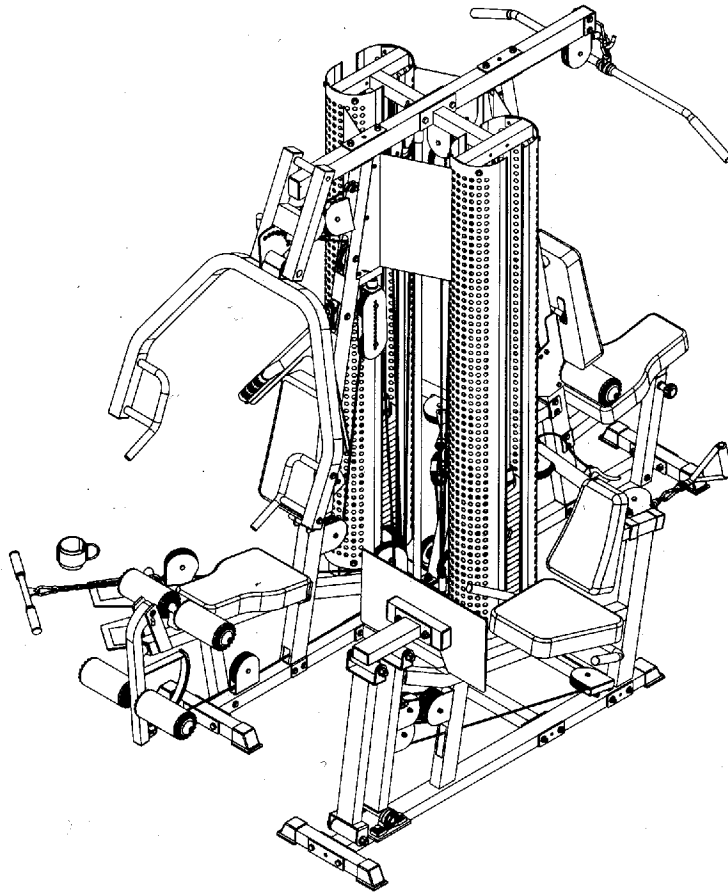

QUESTION?

As a quality home gym supplier we are committed to your complete satisfaction. If you have questions, or find missing or damaged parts, we will guarantee your complete satisfaction through our authorized dealer service centers or our home office customer service department. Please call your local dealer for assistance or RSI at 800-990-5556 (9:00 AM - 5:00 PM). Our trained technicians will provide immediate assistance to you, free of charge.

We stand behind our products. Every piece, every part of this BODYCRAFT strength training system is guaranteed for as long as you own it. We will repair or replace anything that goes wrong.

Bodycraft is a division of Recreation Supply Inc.
P.O. BOX 181
Sunbury, OH 43074

BEFORE YOU BEGIN

Congratulations and thank you for selecting the **BODYCRAFT Family Xpress^{PRO}** strength training system. The **BODYCRAFT Family Xpress^{PRO}** offers an impressive array of strength training exercises to develop every major muscle group of the body. Whether your goal is cardiovascular fitness, a shapely, toned body or dramatic muscle size and strength, the **BODYCRAFT Family Xpress^{PRO}** will help you achieve the specific results you want.

For your safety and benefit, read this manual and the accompanying literature before using the **BODYCRAFT Family Xpress^{PRO}**. Keep this manual for future reference. If you have additional questions, please call your local **BODYCRAFT** dealer or our customer service department at 800-990-5556 Monday through Friday, 9 a.m. until 5 p.m. Eastern Time.

IMPORTANT SAFETY NOTES

There is a risk assumed by individuals who use this type of equipment. Before beginning this or any other exercise program consult your physician. This is especially important for individuals over the age of 35 or persons with pre-existing health problems. Recreation Supply, Inc. assumes no responsibility for personal injury or property damage sustained by or through use of this product.

1. This product must be assembled on a flat, level surface to assure its proper function.
2. Clean pads and frame on a regular basis. We recommend warm, soapy water. Do not use harsh or abrasive chemicals.
3. Inspect and tighten all parts before every use. Replace any worn parts immediately. Failure to do so may result in serious injury.
4. Keep children away from the **BODYCRAFT Family Xpress^{PRO}** at all times.
5. Keep your hands away from cables and pulleys during operation. Keep your hands away from moving parts other than the designated handles.
6. When adjusting the seat, make sure the spring pin is fully engaged. If not, the seat may slip and cause serious injury.
7. Make certain all cables are seated within the pulleys before every use.
8. Exercise with care to avoid injury.
9. If unsure about the proper use of the **BODYCRAFT Family Xpress^{PRO}** strength training system call your local **BODYCRAFT** dealer or our customer service department at 800-990-5556.

EXPLODED VIEW

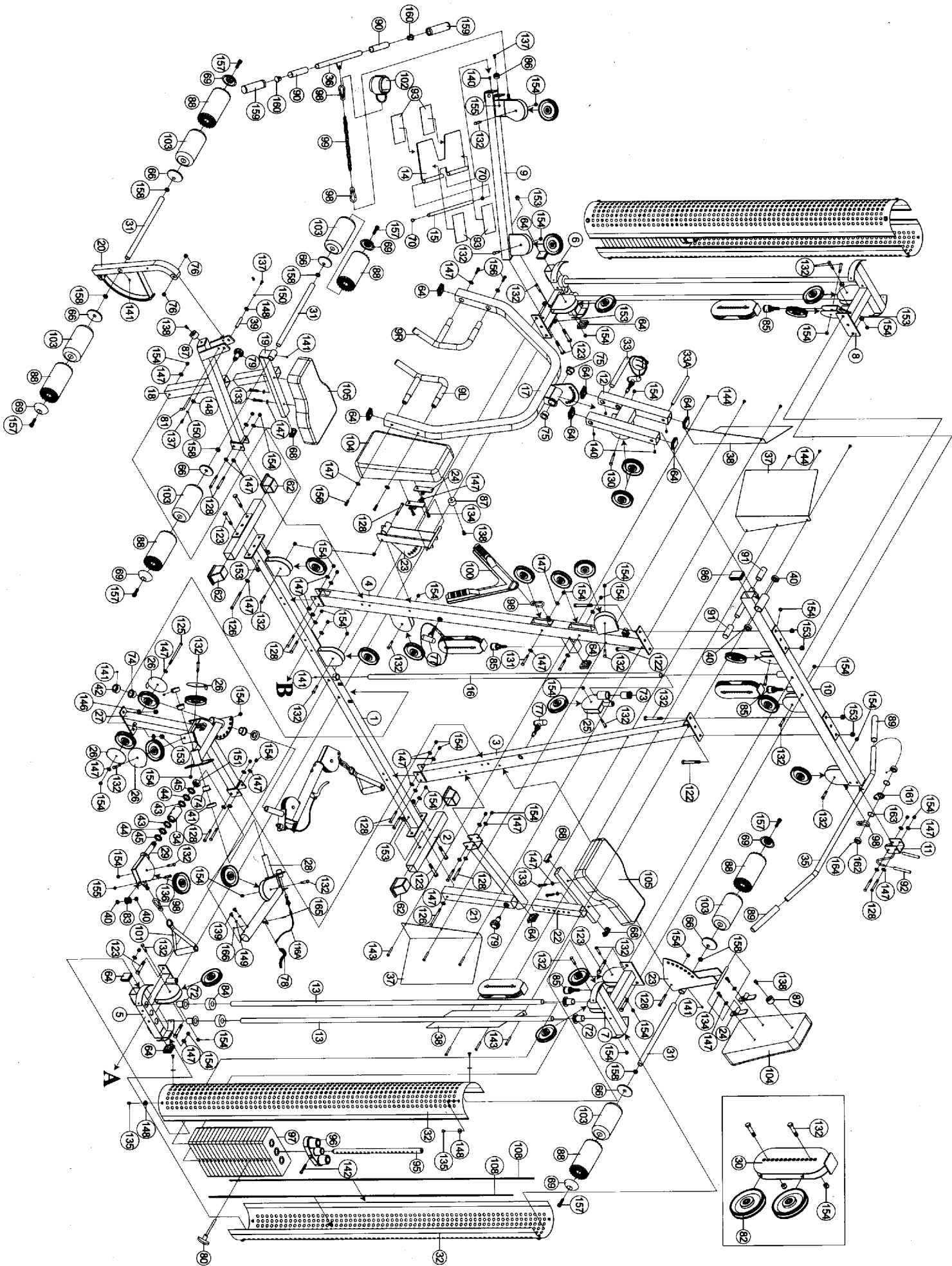

EXPLODED VIEW

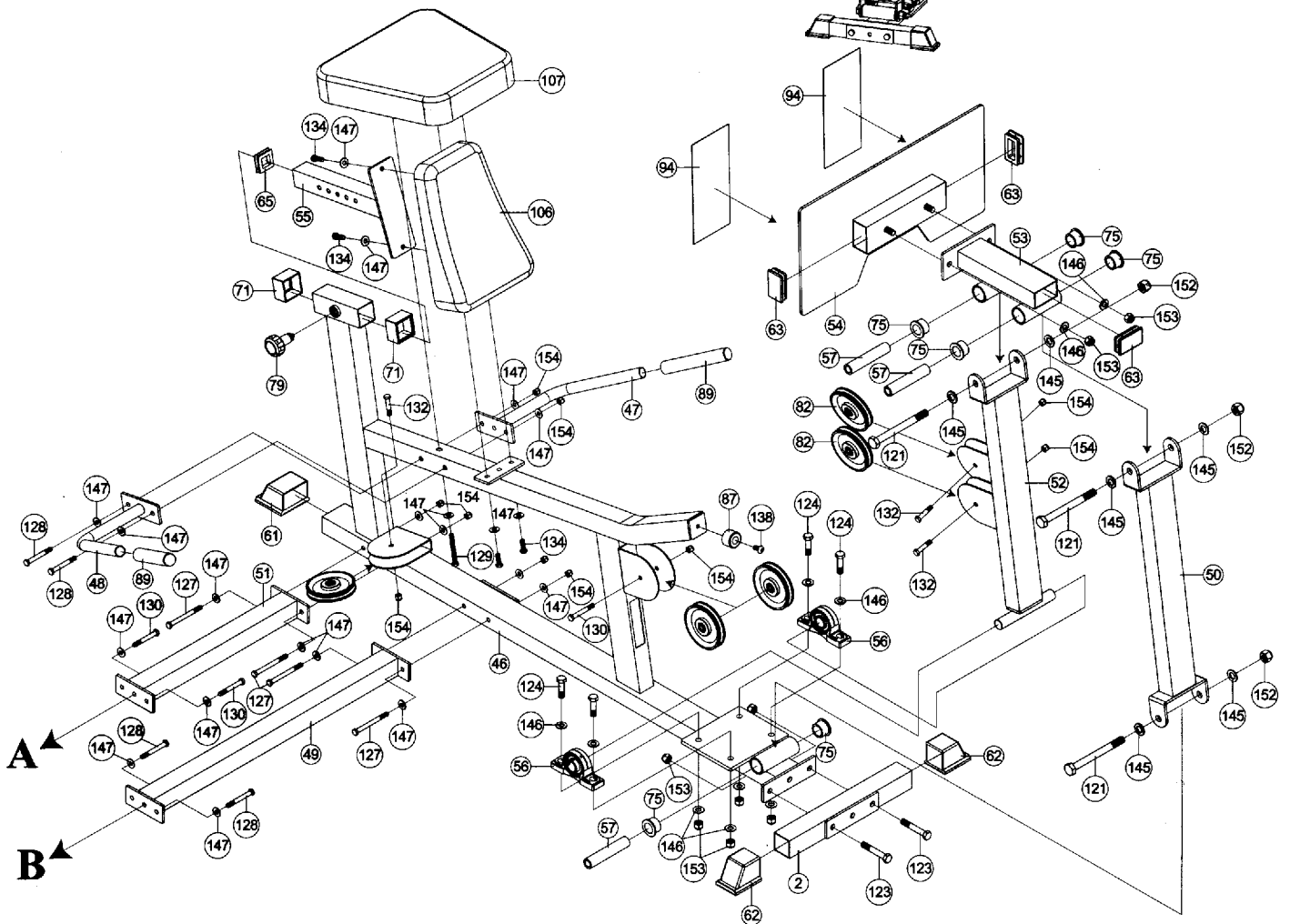
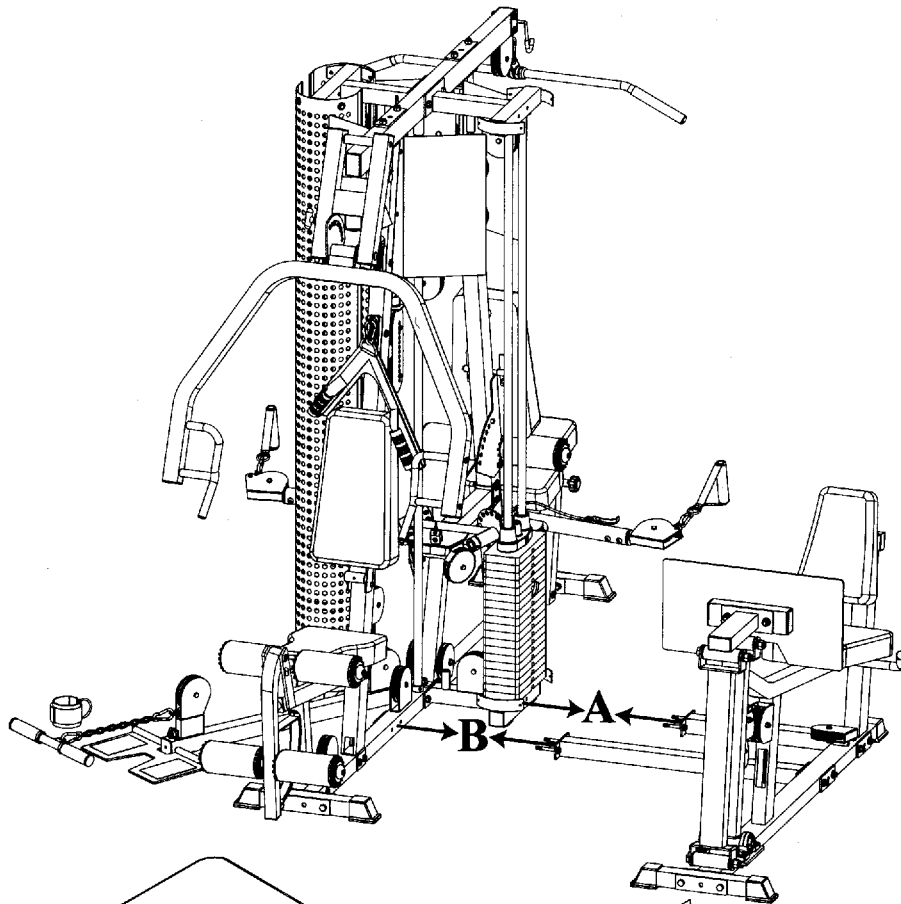

PARTS CHART

NO. DESCRIPTION

QTY.

1	BASE FRAME	1
2	BASE STABILIZER	3
3	REAR UPRIGHT	1
4	FRONT UPRIGHT	1
5	WEIGHT STACK BASE (Leg Press Side)	1
6	WEIGHT STACK BASE (Low Row Side)	1
7	WEIGHT STACK TOP (Leg Press Side)	1
8	WEIGHT STACK TOP (Low Row Side)	1
9	LOW ROW BASE	1
10	TOP FRAME-bearing pre-installed	1
11	LAT BAR HOLDER	1
12	PRESS ARM SELERTOR	1
13	GUIDE ROD (2017mm)	4
14	ROW PLATE	1
15	1/2" ROW PLATE ROLLER	1
16	PULLEY GUIDE ROD (1895mm)	1
17	PRESS ARM	1
17R	RIGHT LEG EXTENSION ARM	1
17L	LEFT LEG EXTENSION ARM	1
18	FRONT SEAT FRAME	1
19	FRONT CHROME SEAT ADJUSTER	1
20	LEG EXTENSION ARM-bearing pre-installed	1
21	REAR SEAT FRAME	1
22	REAR CHROME SEAT ADJUSTER	1
23	SEAT BACK ADJUSTER	2
24	METAL HINGE FOR SEAT BACK ADJUSTER	4
25	SINGLE PULLEY BLOCK	1
26	PULLEY GUIDE BRACKET	4
27	CABLE ARM ASSEMBLY	1
28	CABLE ARM	2
29	SWIVEL CABLE ARM TOP	2
30	ADJUSTABLE PULLEY BLOCK	4
31	1" CHROME ROLLER TUBE	3
32	WEIGHT STACK SHROUD	4
33	1" PIVOT AXLE	1
33A	19.95mm AXLE	1
34	CABLE ARM COLLAR	2
35	LAT BAR	1
36	LOW ROW BAR	1
37	LEFT POSTER PLATE	2
38	RIGHT POSTER PLATE	2
39	LEG EXTENSION AXLE	1
40	608ZB BEARING	2
41	STEEL SPACER(all pre-assembled)	2
42	AXLE COLLAR(all pre-assembled)	2
43	BEARING BASIN(all pre-assembled)	4
44	BEARING(all pre-assembled)	4
45	BEARING COVER(all pre-assembled)	4
46	LEG PRESS MAIN FRAME	1
47	LEFT LEG PRESS HANDLE	1
48	RIGHT LEG PRESS HANDLE	1
49	LONG LEG PRESS CONNECTOR (812mm)	1
50	FRONT LEG PRESS SUPPORT	1
51	LEG PRESS TO WEIGHT BASE CONNECTOR(512mm)	1
52	REAR LEG PRESS SUPPORT	1
53	FOOT PLATE CONNECTOR	1
54	FOOT PLATE	1
55	BACK PAD ADJUSTER	1
56	BEARING HOUSING(all pre-assembled)	2
57	LEG PRESS AXLE	3

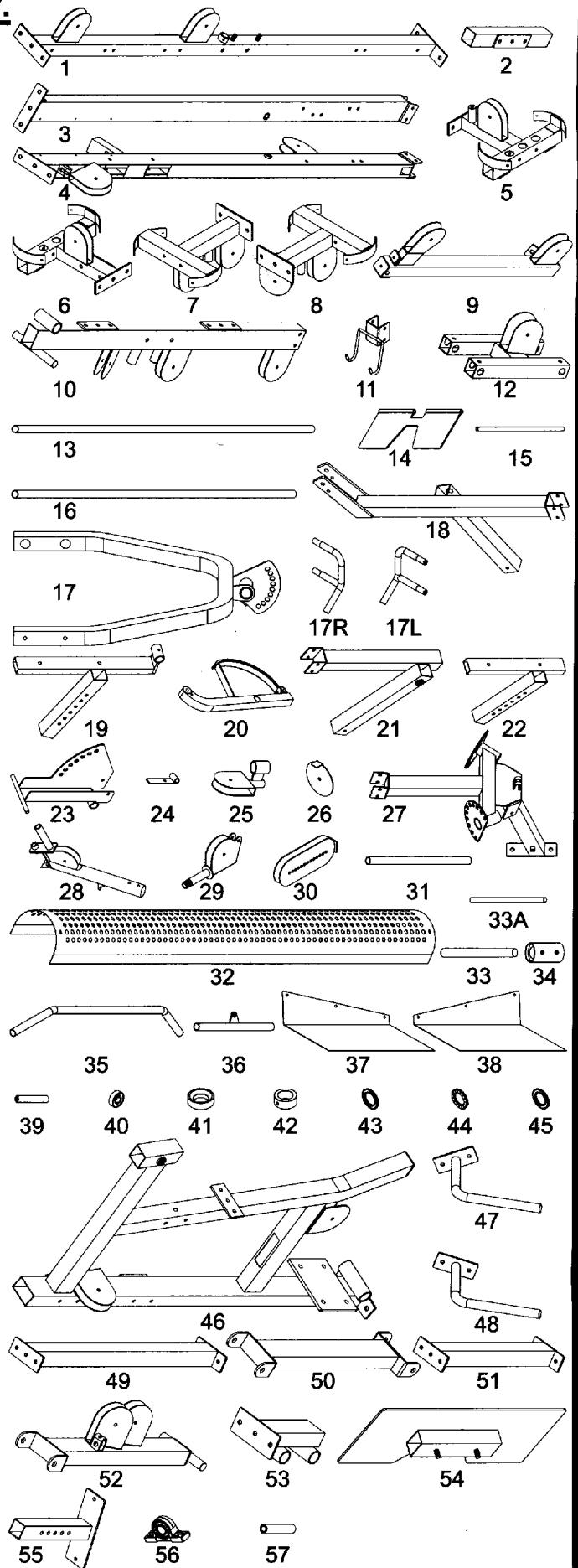





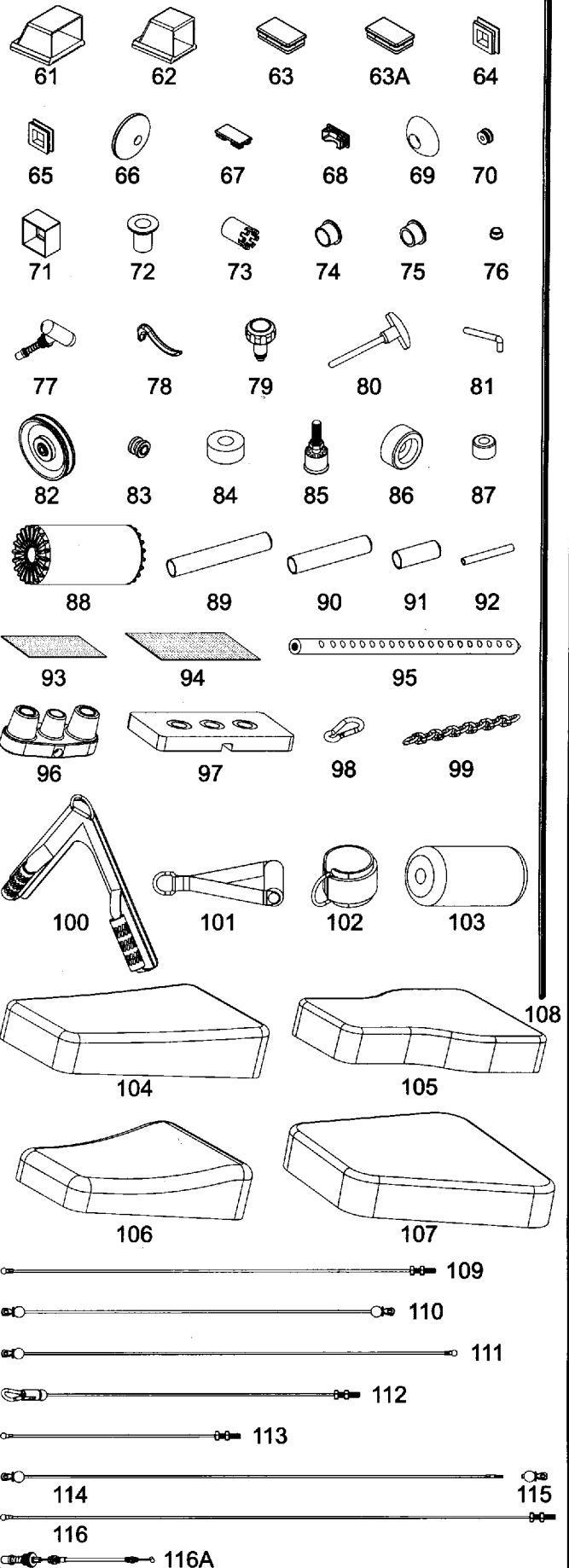



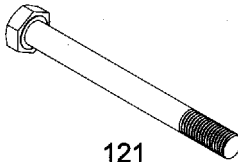



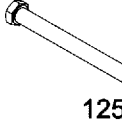
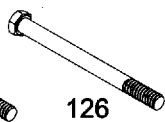
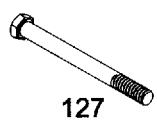





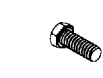



PARTS CHART

NO.	DESCRIPTION	QTY.
61	45 X 75mm RECT. CAP	1
62	50mm SQ. CAP	6
63	45 X 75mm RECT. PLUG	3
63A	50 X 75mm RECT. PLUG	1
64	50mm SQ. PLUG	10
65	45mm SQ. PLUG	1
66	PLASTIC WASHER	6
67	30 X 60mm RECT. PLUG	1
68	25 X 50mm RECT. PLUG	3
69	PLASTIC COVER	6
70	1/2" ROUND PLUG	2
71	SPACER	2
72	PLASTIC GUIDE ROD HOLDER	8
73	1" PLASTIC BUSHING(pre-assembled)	1
74	28.6mm STEEL BUSHING(all pre-assembled)	4
75	25.4mm STEEL BUSHING(all pre-assembled)	8
76	1/2" X 1-1/8" BEARING(all pre-assembled)	2
77	LONGER POP PIN(one pcs. pre-assembled)	3
78	CLUTCH LEVER OF CABLE ARM	2
79	LOCKING SPRING KNOB	3
80	SELECTOR PIN	2
81	L PIN	1
82	PULLEY(four pcs. pre-assembled)	41
83	SMALL PULLEY IN SWIVEL ARM (all pre-assembled)	2
84	RUBBER DONUT	4
85	ADJUSTABLE STOPPER(all pre-assembled)	4
86	1/2" STOPPER(all pre-assembled)	1
87	LEG PRESS STOPPER(all pre-assembled)	4
88	COVER OF FOAM PAD	6
89	1" X 200mm HAND GRIP(all pre-assembled)	4
90	1" X 140mm HAND GRIP(all pre-assembled)	2
91	1" X 70mm PRESS ARM STOPPER (all pre-assembled)	2
92	LAT BAR HOLDER COVER(95mm) (all pre-assembled)	2
93	100 X 150mm NON SLIP	4
94	120 X 280mm NON SLIP	2
95	SELECTOR ROD	2
96	TOP PLATE	2
97	10 LB. PLATE	38
98	SNAP HOOK	6
99	LOW ROW CHAIN	1
100	AB CRUNCH STRAP	1
101	SINGLE HANDLE	2
102	ANKLE STRAP	1
103	FOAM PAD	6
104	BACK PAD	2
105	SEAT PAD	2
106	BACK PAD FOR LEG PRESS	1
107	SEAT PAD FOR LEG PRESS	1
108	TRIM FOR WEIGHT SHROUD	8
109	PRESS CABLE	1
110	LOW CABLE	1
111	AB CRUNCH CABLE	1
112	TOP CABLE	1
113	CABLE ARM CONNECTING CABLE	1
114	CABLE ARM CABLE(pre-assembled)	1
115	REMOVABLE END CABLE ARM CABLE (pre-assembled)	1
116	LEG PRESS CABLE	1
116A	CLUTCH CABLE	2



PARTS CHART

NO.	DESCRIPTION	QTY.	
121	5/8" X 6-1/2" HEX BOLT	3	
122	1/2" X 4" HEX BOLT	4	
123	1/2" X 3" HEX BOLT	12	
124	1/2" X 1-3/4" HEX BOLT	4	
125	3/8" X 5-3/4" HEX BOLT	1	
126	3/8" X 4-1/2" HEX BOLT	2	
127	3/8" X 4" HEX BOLT	4	
128	3/8" X 3" HEX BOLT	18	
129	3/8" X 2-3/4" HEX THREADED BOLT	1	
130	3/8" X 2-3/4" HEX BOLT	4	
131	3/8" X 2-1/2" HEX BOLT	2	
132	3/8" X 1-3/4" HEX BOLT(four pcs. pre-assembled)	33	
133	3/8" X 1-3/4" HEX THREADED BOLT	4	
134	3/8" X 1" HEX THREADED BOLT	8	
135	5/16" X 1/2" HEX THREADED BOLT	16	
136	5/16" X 1-1/2" SET SCREW(all pre-assembled)	2	
137	5/16" X 5/8" SET SCREW(all pre-assembled)	3	
138	3/8" X 5/8" SET SCREW(all pre-assembled)	4	
139	3/8" X 1/2" ROUND BOLT(all pre-assembled)	4	
140	3/8" X 1/2" SET SCREW(all pre-assembled)	5	
141	5/16" X 1/4" SET SCREW(all pre-assembled)	5	
142	TOP PLATE BOLT	2	
143	8mm X 53mm FEMALE BOLT FOR POSTER	6	
144	6mm X 12mm MALE NUT FOR POSTER	6	
145	5/8" WASHER	6	
146	1/2" WASHER(four pcs. pre-assembled)	12	
147	3/8" WASHER	67	
148	5/16" WASHER(two pcs. pre-assembled)	18	
149	3/8" SPRING WASHER(all pre-assembled)	4	
150	5/16" SPRING WASHER(all pre-assembled)	2	
151	24mm NYLON NUT(all pre-assembled)	2	
152	5/8" NYLON NUT	3	
153	1/2" NYLON NUT(four pcs. pre-assembled)	23	
154	3/8" NYLON NUT(four pcs. pre-assembled)	64	
155	5/16" NYLON NUT(all pre-assembled)	3	
156	3/8" X 5/8" INNER HEX SCREW	4	
157	5/16" X 32mm SUNKEN HEAD SCREW	6	
158	5/16" NUT	6	
159	1-1/4" HAND GRIP	2	
160	1" T SHAPE END PLUG	2	
161	HOOK PLATE	1	
162	COLLAR	2	
163	SEALING RING	2	
164	M6 SET SCREW	2	
165	M5 X 18mm ROUND HEAD SCREW	2	
166	M5 NYLON NUT	2	



STEP 1 ASSEMBLE BASE FRAME

To ease the assembly process, do not tighten bolts until instructed.

1. Attach Base Stabilizers(2) to each end of Base Frame(1), using two 1/2" X 3" Hex Head Bolt(123) and two 1/2" nut(153). Attach 50mm SQ. Cap(62) onto front & rear Base Stabilizers(2).
2. Attach Weight Stack Base - Leg Press Side(5) and Weight Stack Base - Low Row Side(6) to Base Frame(1) using two 1/2" X 3" Hex Head Bolts(123), two 1/2" Washers(146) and two 1/2" Nylon nuts (153). Attach four 50mm SQ. Plugs(64) and insert four Plastic Guide Rod Holders(72) to both Weight Stack Bases(5, 6).
3. Attach Front Upright(4) to Base Frame(1) using two 3/8" X 3" Hex Head Bolts(128), four 3/8" Washers (147) and two 3/8" Nylon Nuts(154). Repeat process for Rear Upright(3). Screw Longer Pop Pin(77) into Front Upright(4) and Rear Upright(3) as shown.
4. Attach Low Row Base(9) to Weight Stack Base(6) using two 1/2" X 3" Hex Head Bolts(123) and one 1/2" Nylon Nut(153). Attach Row Plate(14) to Low Row Base(9) by inserting 1/2" Row Plate Roller(15). Insert 1/2" Round Plug(70) into 1/2" Row Plate Roller(15). Attach 100 X 150mm Non Slip(93) to Row Plate(14).
5. Attach Leg Press To Weight Base Connector(51) to Weight Stack Base(5) using two 3/8" X 2-3/4" Hex Bolts(130), four 3/8" Washers(147) and two 3/8" Nylon Nuts(154).
6. Attach Long Leg Press Connector(49) to Base Frame(1) using two 3/8" X 3" Hex Head Bolts(128), four 3/8" Washers(147) and two 3/8" Nylon Nuts(154).

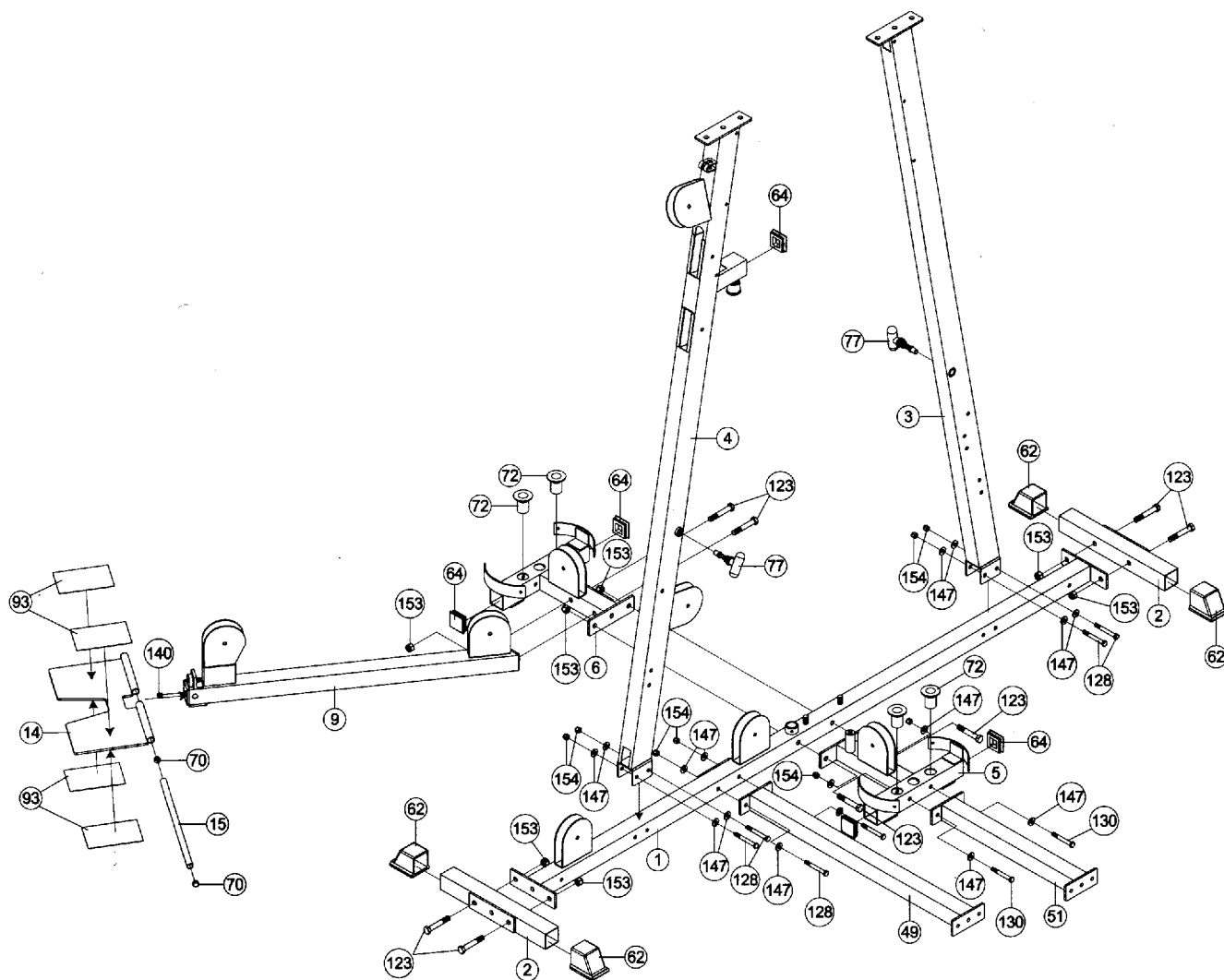

STEP 2 ASSEMBLE TOP FRAME

1. Attach Top Frame - bearing pre-installed(10) to Front and Rear Uprights(3, 4) using two 1/2" X 4" Hex Head Bolts(122) and two 1/2" Nylon Nuts(153). Attach Lat Bar Holder(11) to Top Frame - bearing pre-installed(10) using two 3/8" X 3" Hex Head Bolts(128), four 3/8" Washers(147) and two 3/8" Nylon Nuts(154).
2. Slide two Rubber Donuts(84) onto one end of each Guide Rod(13) and then insert Guide Rod(13) into the Plastic Guide Rod Holders(72) in Weight Stack Bases(5, 6) as shown.
3. Slide each 10 LB Plate(97) over Guide Rods(13). Make certain that each plate is oriented with selector hole on bottom and facing forward. Attach Top Plate(96) to Selector Rod(95) using Top Plate Bolt(142). Slide Top Plate(96) and Selector Rod(95) over Guide Rod(13). Insert Plastic Guide Rod Holders(72) into both Weight Stack Tops(7, 8) and then slide both Weight Stack Tops(7, 8) over top of Guide Rods(13) and attach to Top Frame - bearing pre-installed(10), using two 1/2" X 3" Hex Head Bolts(123) and two 1/2" Nylon Nuts(153). Refer to drawing to be certain each Weight Stack Top(7,8) is on proper side.
4. Attach pre-assembled Cable Arm Assembly(27) to Rear Upright(3) and Base Frame(1) using two 3/8" X 3" Hex Head Bolts(128), four 3/8" Washers(147) and two 3/8" Nylon Nuts(154). Attach pre-assembled Cable Arm Assembly(27) to Base Frame(1) using two 1/2" Washers(146) and two 1/2" Nylon Nuts(153) onto pre-welded bolts on Base Frame(1). Remember to keep all bolts loose to ensure holes will align easily.
5. Slide the axle of each Cable Arm(28) through the hole in selector plate of Cable Arm Assembly(27) and fasten using Axle Collar(42) with 5/16" X 5/8" pre-inserted Set Screw(141).

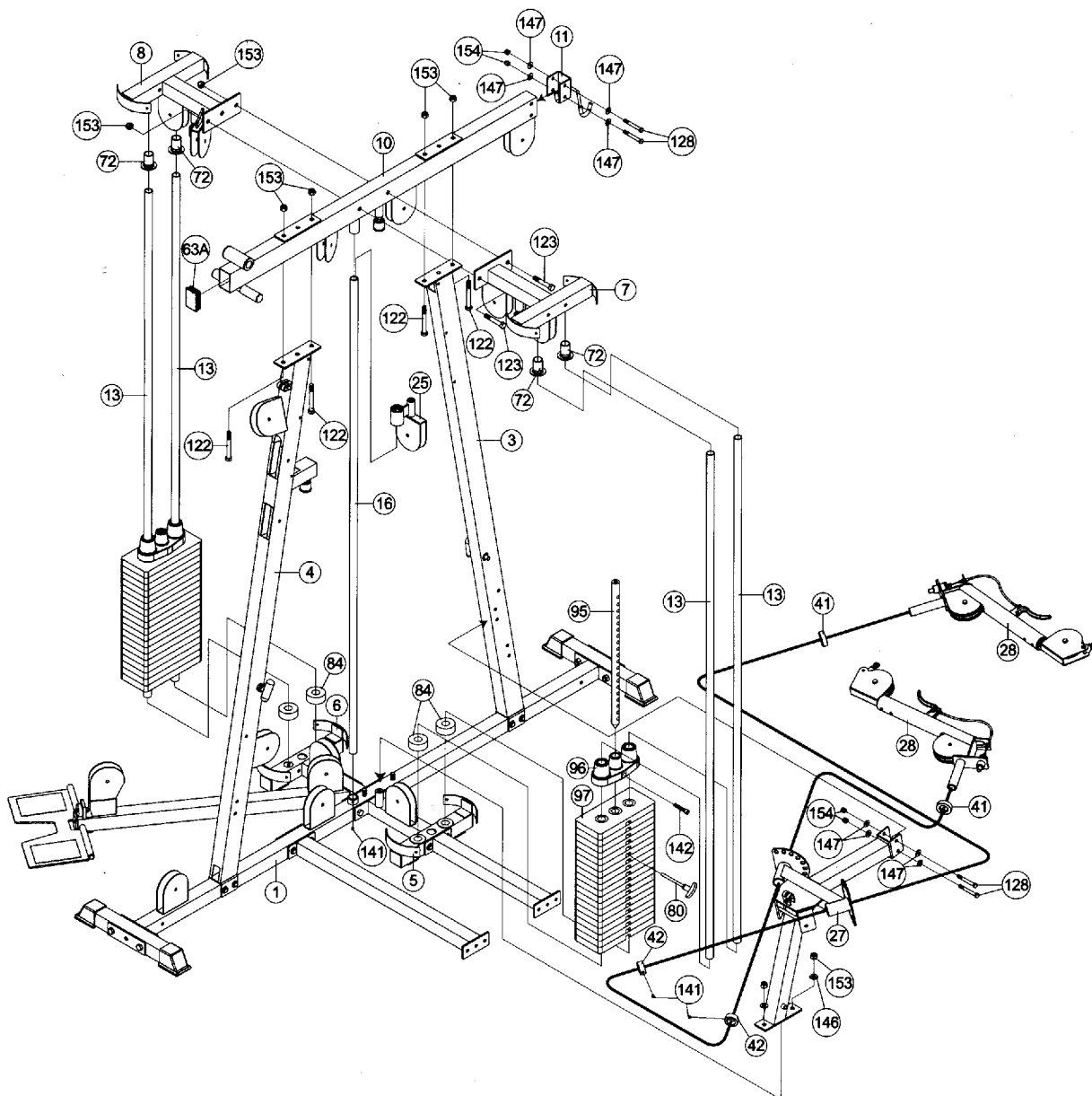

STEP 4 ASSEMBLE BENCH PRESS AND LEG PRESS

1. Attach Press Arm Selector(12) to Top Frame - bearing pre-installed(10) by aligning holes and inserting 1" Pivot Axle(33). Lock into place with pre-installed set screw.
2. Attach Press Arm(17) to Press Arm Selector(12) by aligning holes and inserting 1" Pivot Axle(33), 19.95mm Axle(33A). Lock into place with pre-installed set screw. Attach 50mm SQ. Plug(64) onto ends of Press Arm(17) and Press Arm Selector(12).
3. Check Longer Pop Pin(77) into Press Arm Selector(12), making sure Pop Pin(77) seats into adjustment holes in Press Arm(17).
4. Attach Leg Press Main Frame(46) to Leg Press to Weight Base Connector(51) and Long Leg Press Connector(49), using two 3/8" X 4" Hex Bolts(127), four 3/8" Washers(147) and two 3/8" Nylon Nuts(154).
5. Attach Base Stabilizer(2) to Leg Press Main Frame(46) using two 1/2" X 3" Hex Head Bolts(123) and two 1/2" Nylon Nuts(153). Attach 45 X 75mm Rect. Cap(61) to rear of Leg Press Main Frame(46) and two 50mm SQ. Caps(62) to Base Stabilizer(2).
6. Remove one Bearing Housing(56) from Leg Press Main Frame(46). Slide Axle on Rear Leg Press Support(52) into each Bearing Housing(56), then attach Bearing Housing(56) back onto Leg Press Main Frame(46). Attach Front Leg Press Support(50) to Leg Press Main Frame(46) using one 5/8" X 6-1/2" Hex Head Bolt(121), two 5/8" Washers(145) and one 5/8" Nylon Nut(153).
7. Slide both Leg Press Axles(57) through pre-installed 1" Bushings(75) on Foot Plate Connector(53). Attach Foot Plate Connector(53) to Rear Leg Press Support(52) and Front Leg Support(50) using one each 5/8" X 6-1/2" Hex Head Bolt(121), two 5/8" Washers(145) and one 5/8" Nylon Nut(152).
8. Attach Foot Plate(54) to Foot Plate Connector(53), using two 1/2" Washers(146) and two 1/2" Nylon Nuts(153). Attach 45 X 75mm Rect. Plugs(64) to Foot Plate(54). Attach Right and Left Leg Press Handles(47, 48) to Leg Press Main Frame(46), angle facing up, using two 3/8" X 3" Hex Head Bolts(128), four 3/8" Washers(147) and two 3/8" Nylon Nuts(154). Attach Seat Pad for Leg Press(107) to Leg Press Main Frame(46), using two 3/8" Washers(147) and two 3/8" X 1" Hex Head Bolts(134), one 3/8" X 2-3/4" Hex Head Bolt(129). Attach Back Pad for Leg Press(106) to Back Pad Adjuster(55) using two 3/8" Washers(147) and two 3/8" X 1" Hex Head Bolts(134). Slide Back Pad Adjuster(55) into Leg Press Main Frame(46) by pulling pre-installed Locking Spring Knob(79).

Tighten all the bolts and nuts gradually, from ground - up.

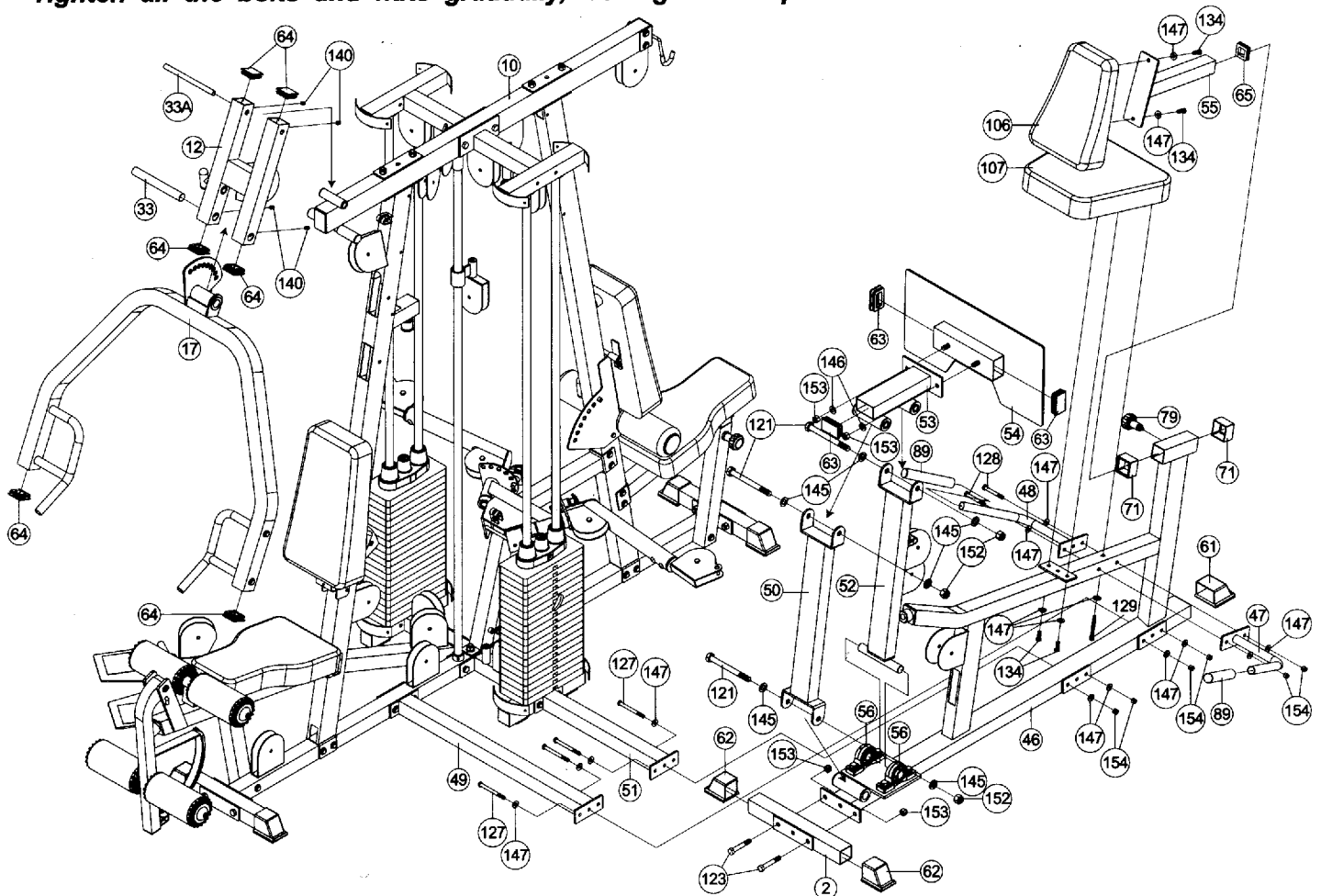

PRESS CABLE 169" (4290mm) length

Assemble cables and pulleys simultaneously.

Attach loop end of Press Cable(109) to the bracket on Front Upright(4). Route cable over and around left (as if sitting on seat) side pulley mounted in Press Arm Selector(12), under and around pulley mounted in Front Upright(4), over and around right side pulley in Press Arm Selector(12) as shown Fig. 2. Continue through (uppermost) slot and over pulley in Front Upright as shown in Fig. 3, under top pulley in Adjustable Pulley Block(30), up and over pulley mounted on Top Frame(10), as shown in Fig. 4, down and around top pulley in Adjustable Pulley Block(30), up and over pulley mounted in Weight Stack Top(8&9), and down to weight stack. Screw Press Cable(109) end into Selector Rod(95) at least 7 threads as shown in Fig. 6.

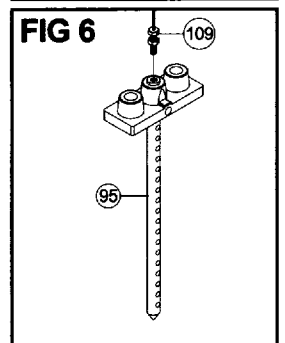
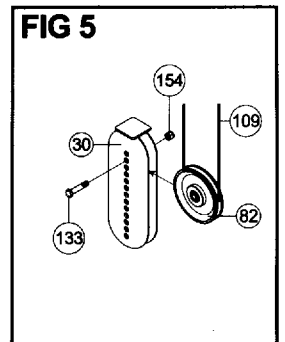
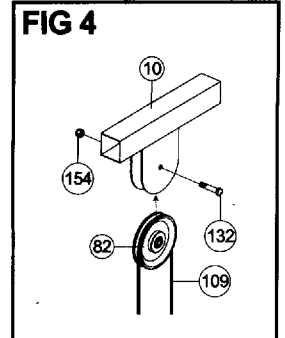
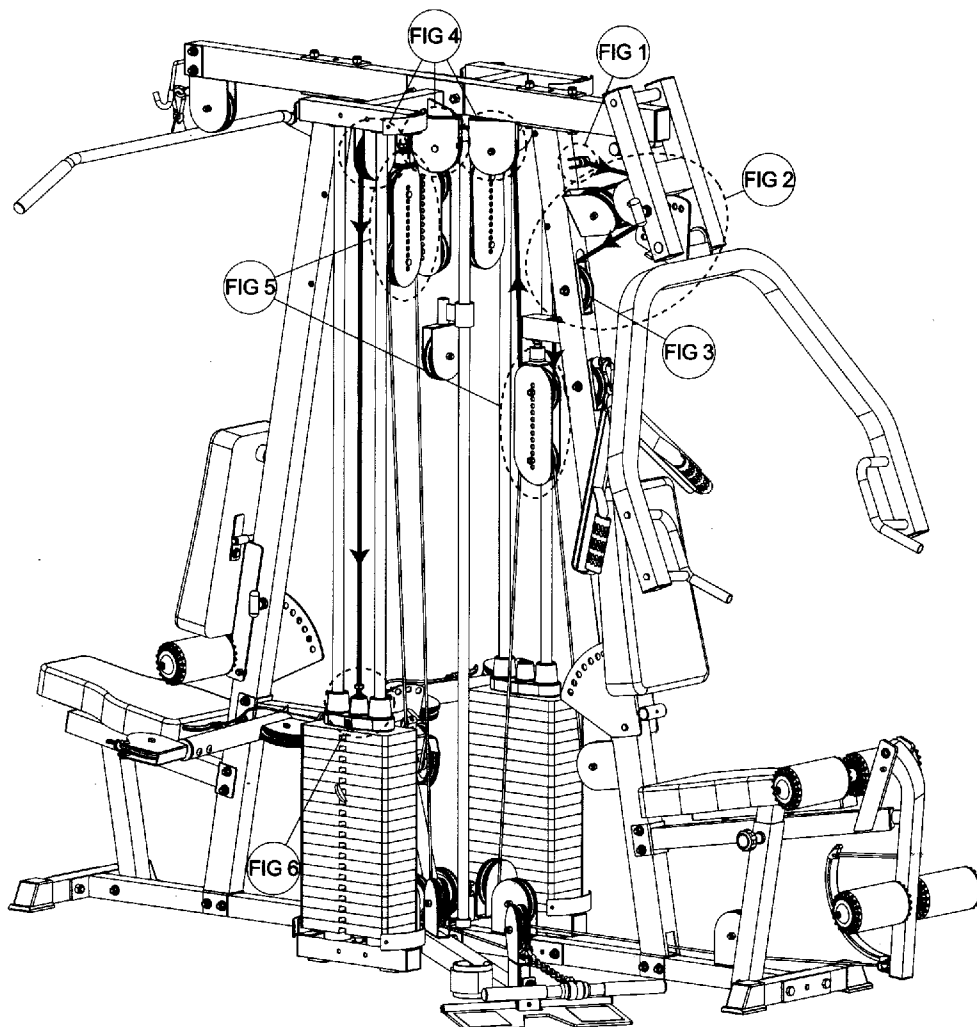
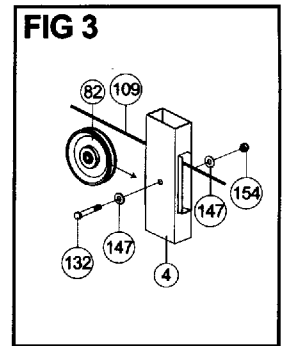
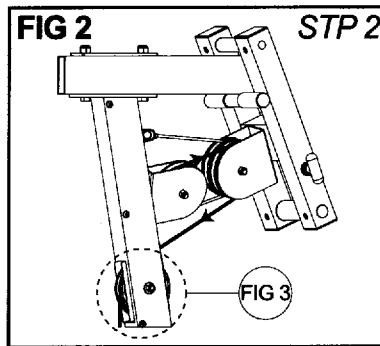
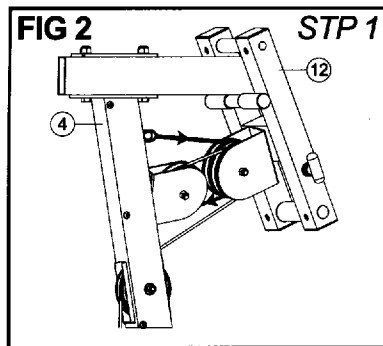
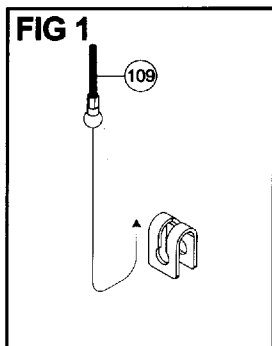

LOW CABLE 166" (4210mm) length

Route Low Cable(110) under two Pulleys(82) on Low Row Base(9) as shown in Fig. 1, and 2, up over lower pulley in Adjustable Pulley Block(30) as shown in Fig. 3, down and ending under the pulley on Weight Stack Base(6) as shown in Fig. 4.

Do not use this cable if you have purchased this option Hip Station. Use this Hip Station Cable instead.

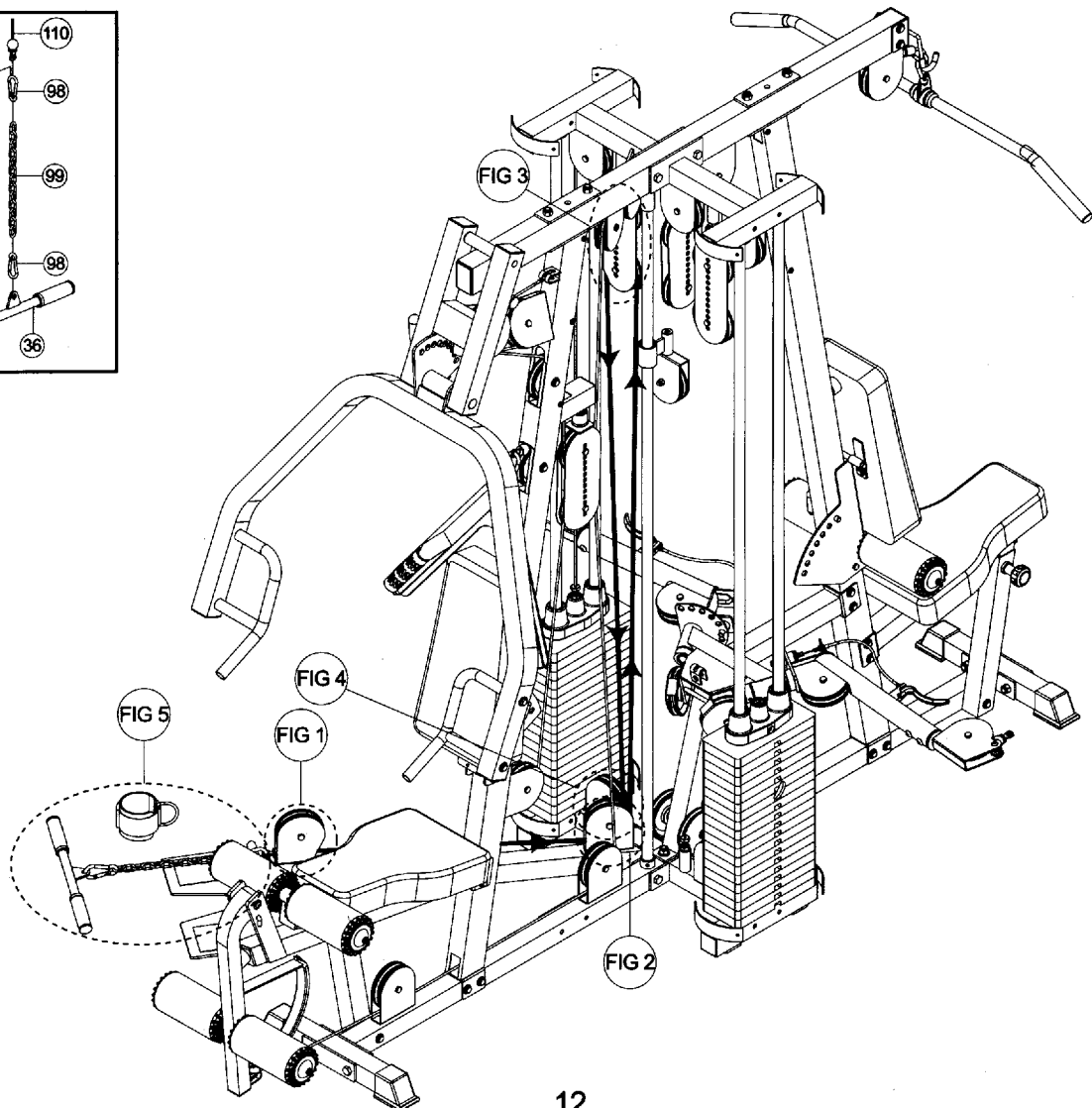
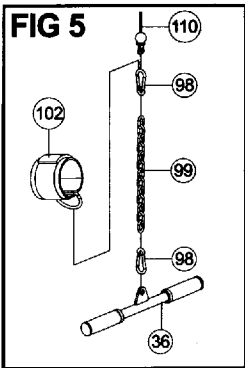
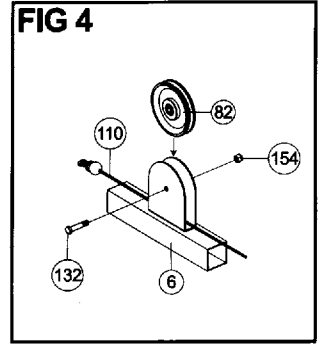
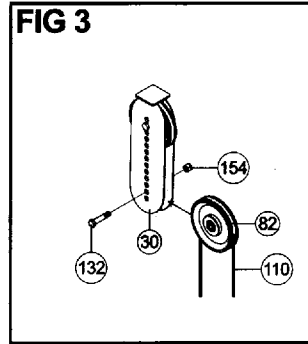
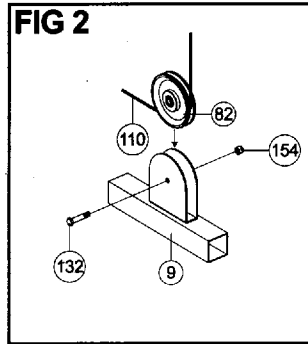
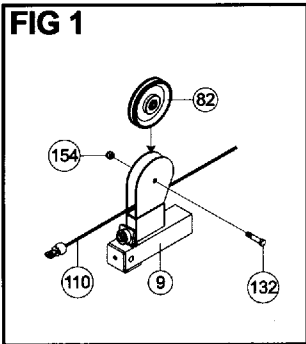

AB CRUNCH CABLE 170" (4320mm) length

Route the AB Crunch Cable(111) through(lower) slot and over pulley in Front Upright(4) as shown in Fig. 2, down and around the pulley mounted on rear of Front Upright(4), up and over lower pulley in Adjustable Pulley Block(30) as shown in Fig. 4, down and under two pulleys mounted on Base Frame (1) and attach cable end to bracket welded on Leg Extension Arm(20) as shown in Fig. 5.

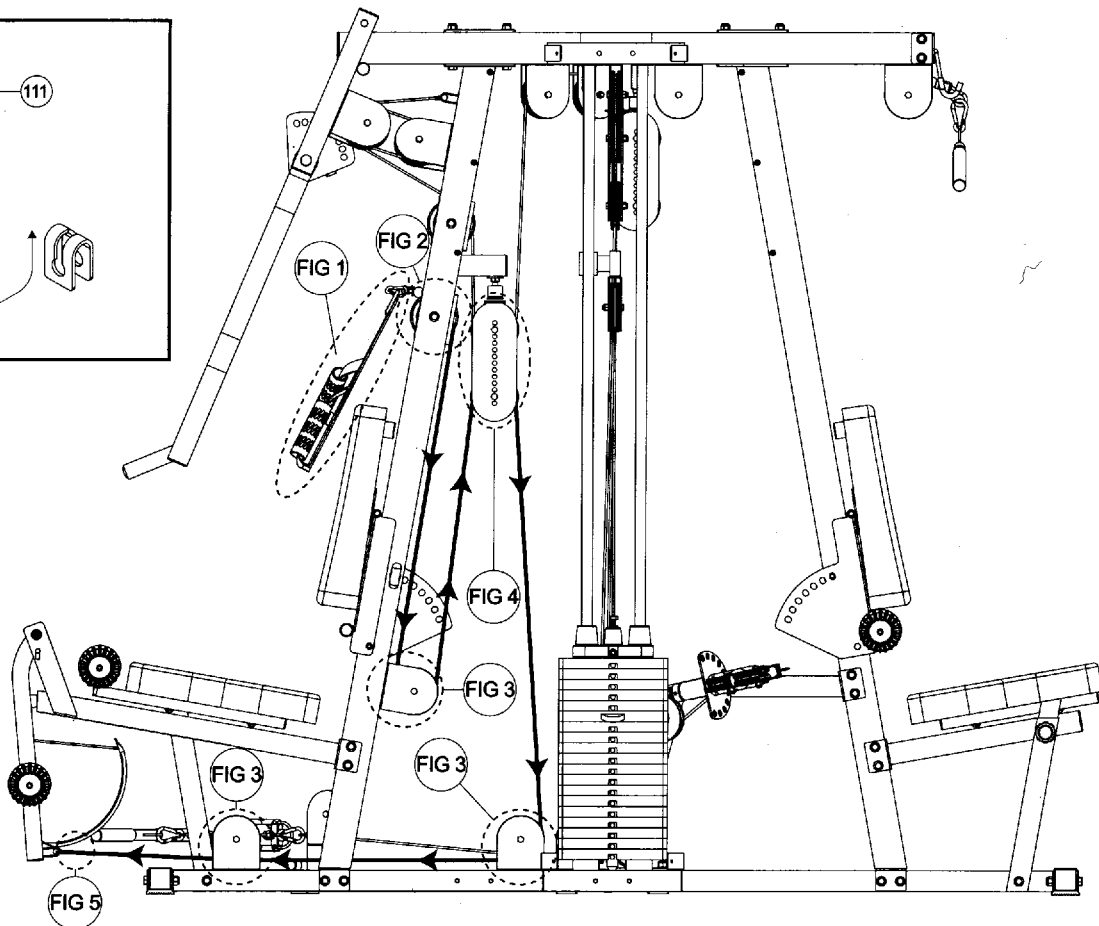
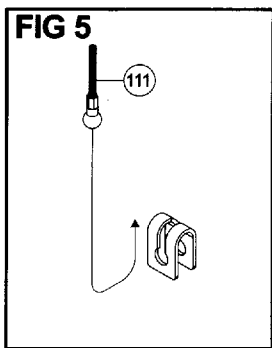
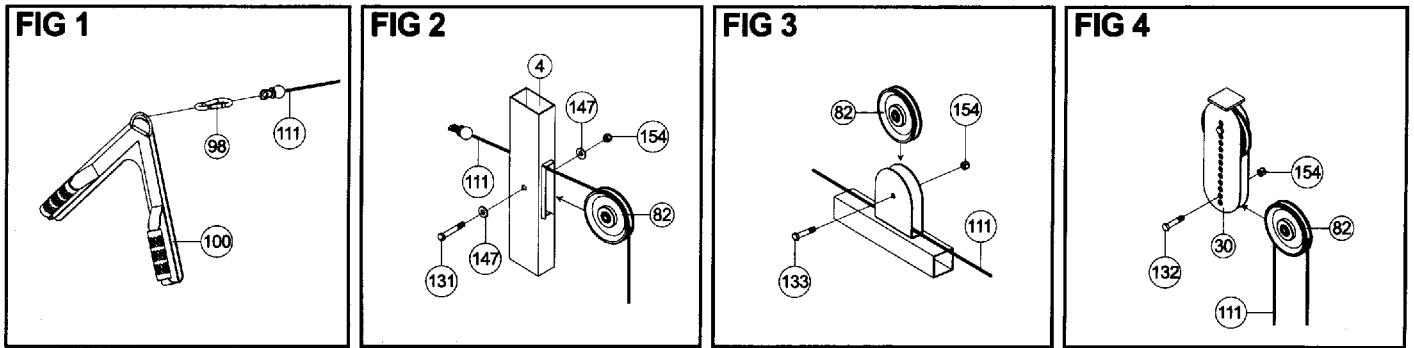

TOP CABLE 120" (3060mm) length

Route threaded end of Top Cable(112) over pulley mounted to Top Frame(10) as shown in Fig. 1, through slot in Rear Upright, over pulley in Top Frame(10), under and around top pulley in Pulley Block, up and over pulley mounted on Weight Stack Top, under top pulley in Adjustable Pulley Block as shown in Fig. 3, up and over pulley mounted to Weight Stack Top as shown in Fig. 2, and down to weight stack.
Screw

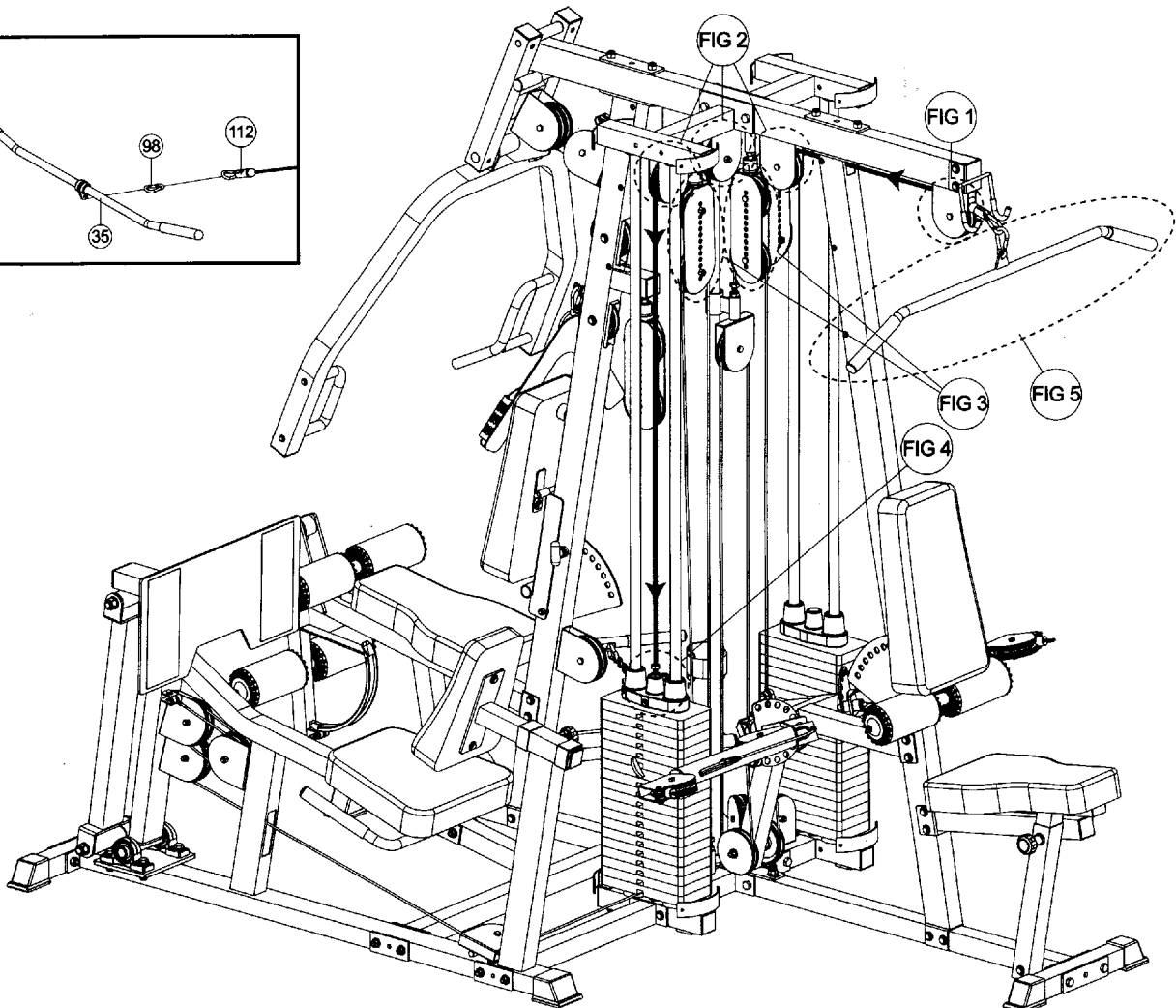
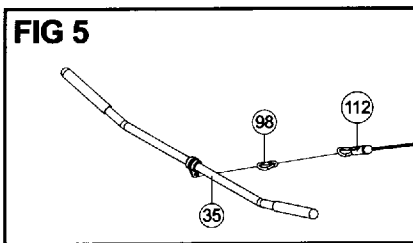
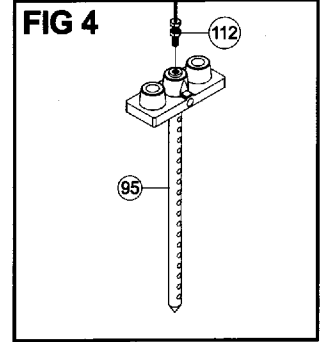
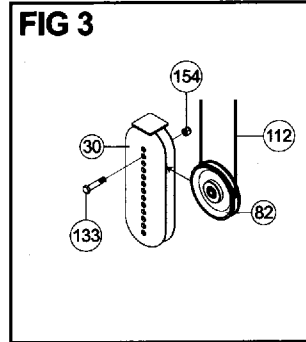
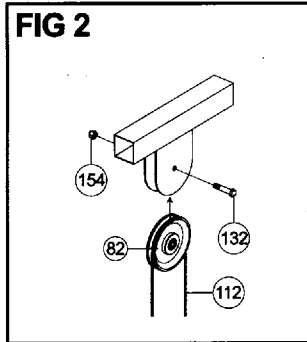
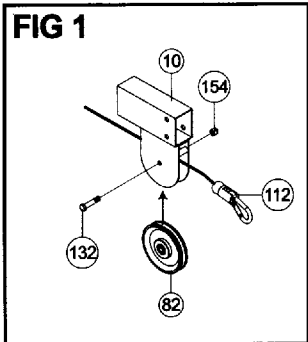

CABLE ARM CONNECTING CABLE 55" (1400mm) length

Hook Cable Arm Connecting Cable(113) on bracket welded to Cable Arm Assembly(27) then route up and over low pulley in Adjustable Pulley Block(30) as shown in Fig. 2, then screw threaded cable end into Single Pulley Block(25).

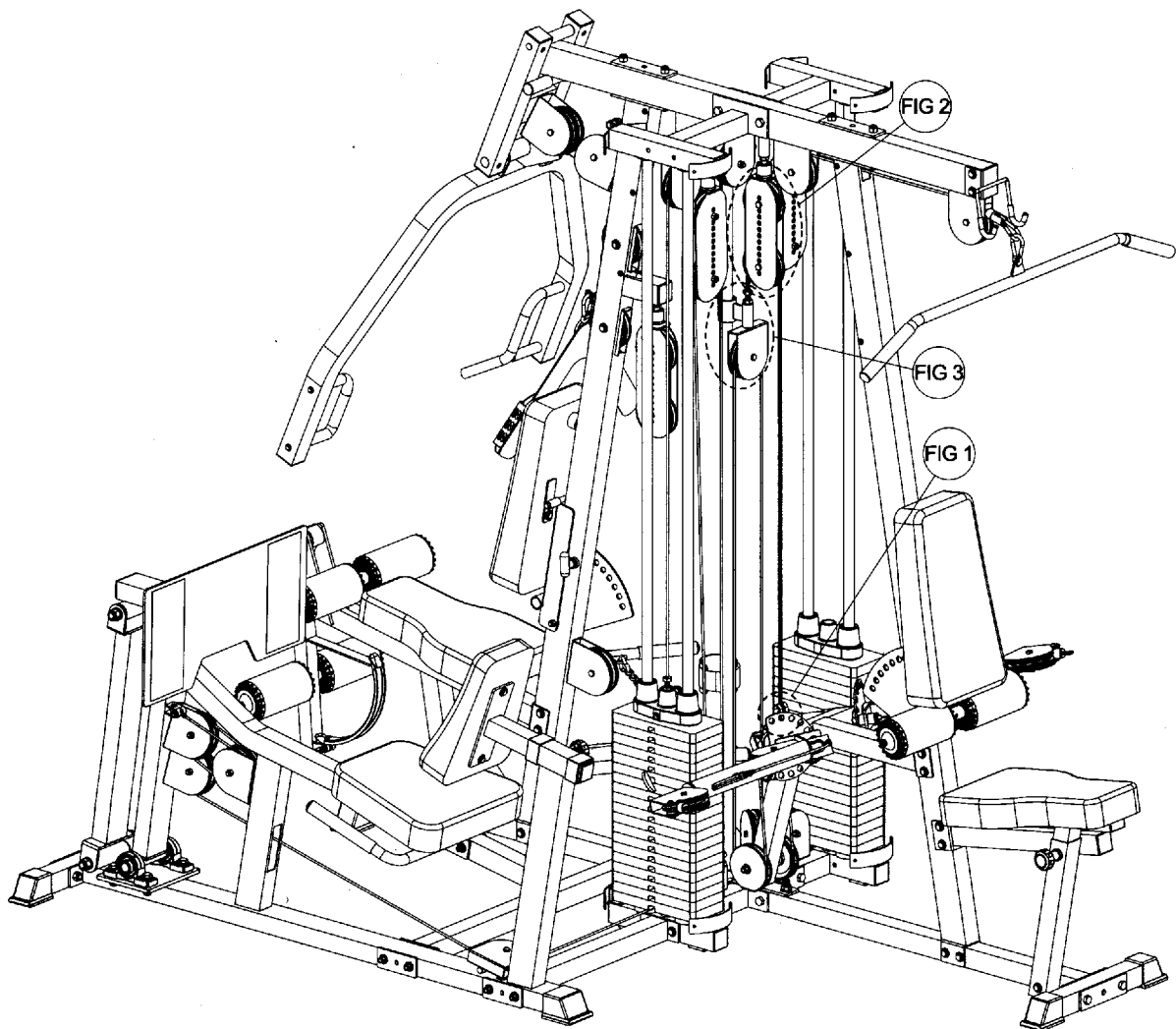
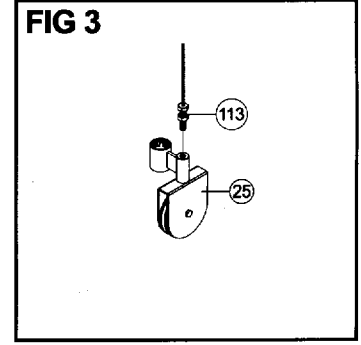
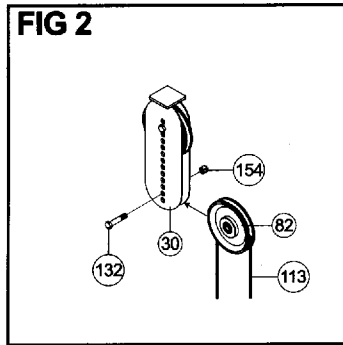
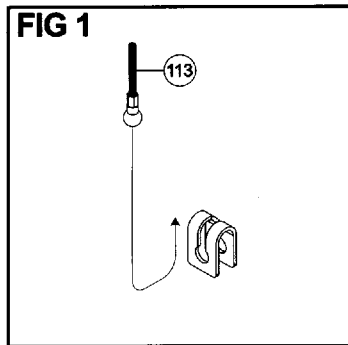

CABLE ARM CABLE 214" (5445mm) length

Slide Single Pulley Block(25) onto Pulley Guide Rod(16). Insert top end of Pulley Guide Rod(16) into top guide rod holder welded to Top Frame(10). Push Pulley Guide Rod(16) up into hole as far as possible, then slide bottom end of Pulley Guide Rod(16) into guide rod holder welded to Base Frame(1). Secure Pulley Guide Rod(16) by tightening pre-installed set screw. Attach pulleys and Pulley Guide Brackets(26) to Cable Arm Assembly(27) as shown in Fig. 3 and Fig. 4. Be certain that, when tightened, the pulley guide brackets do not interfere with cable movement. Route Cable Arm Cable(114) around these pulleys as shown, up and around pulley in the Single Pulley Block(25).

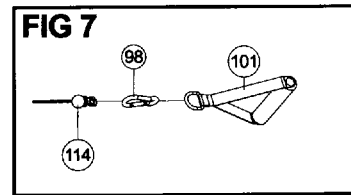
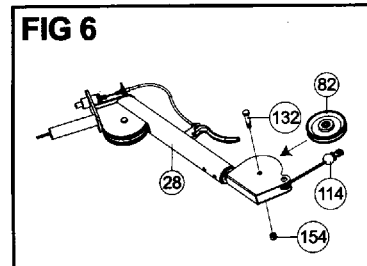
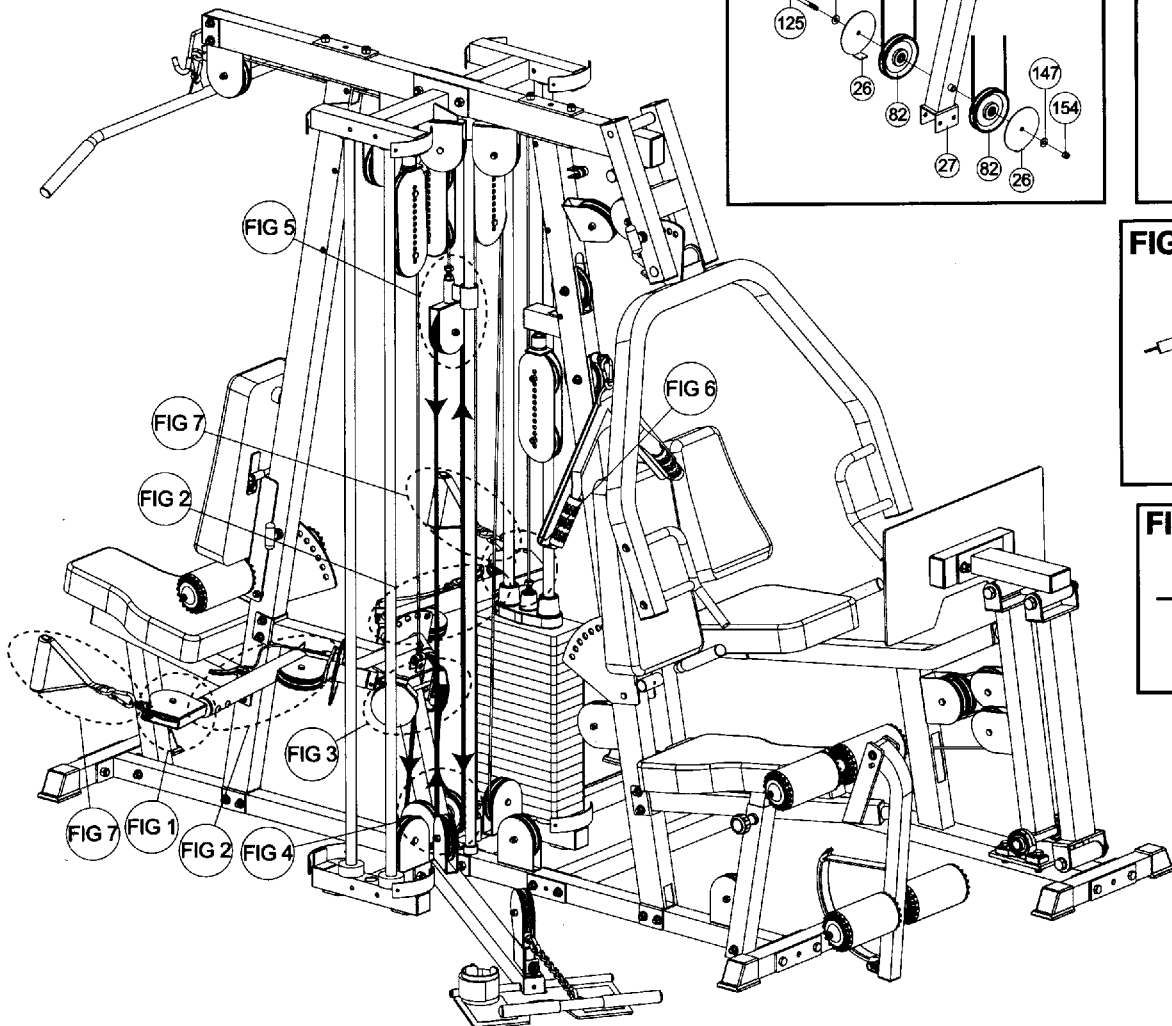
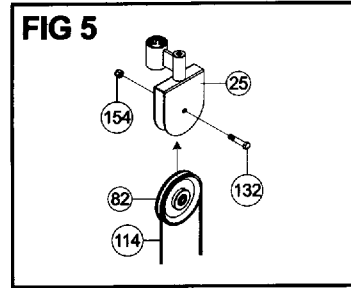
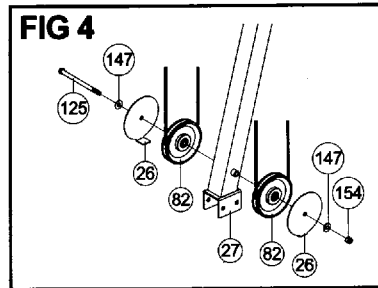
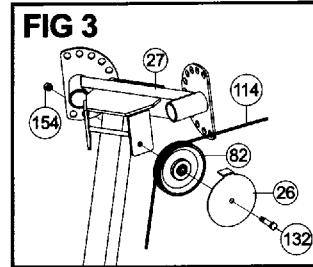
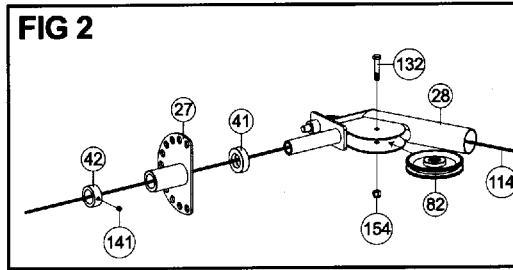
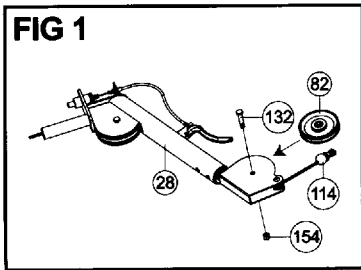

LEG PRESS CABLE 250" (6350mm) length

Screw threaded end (approx. half way) of Leg Press Cable(116) into receiver on Base Frame(1). Route cable up and over the lower pulley in Adjustable Pulley Block(30), then down and under the pulley on Weight Stack Base(4) as shown in Fig. 1, and around horizontal pulley on Leg Press Main Frame(46). Route cable under and around lowest pulley mounted on Rear Leg Press Support(52), under and around right side (as if sitting on seat) pulley on Leg Press Main Frame(46), over and around top pulley on Rear Leg Press Support(52), under and around left side pulley on Leg Press Main Frame(46) as shown in Fig. 5. Then hook the terminal end of cable on bracket on Rear Leg Press Support(52) as shown in Fig. 6.

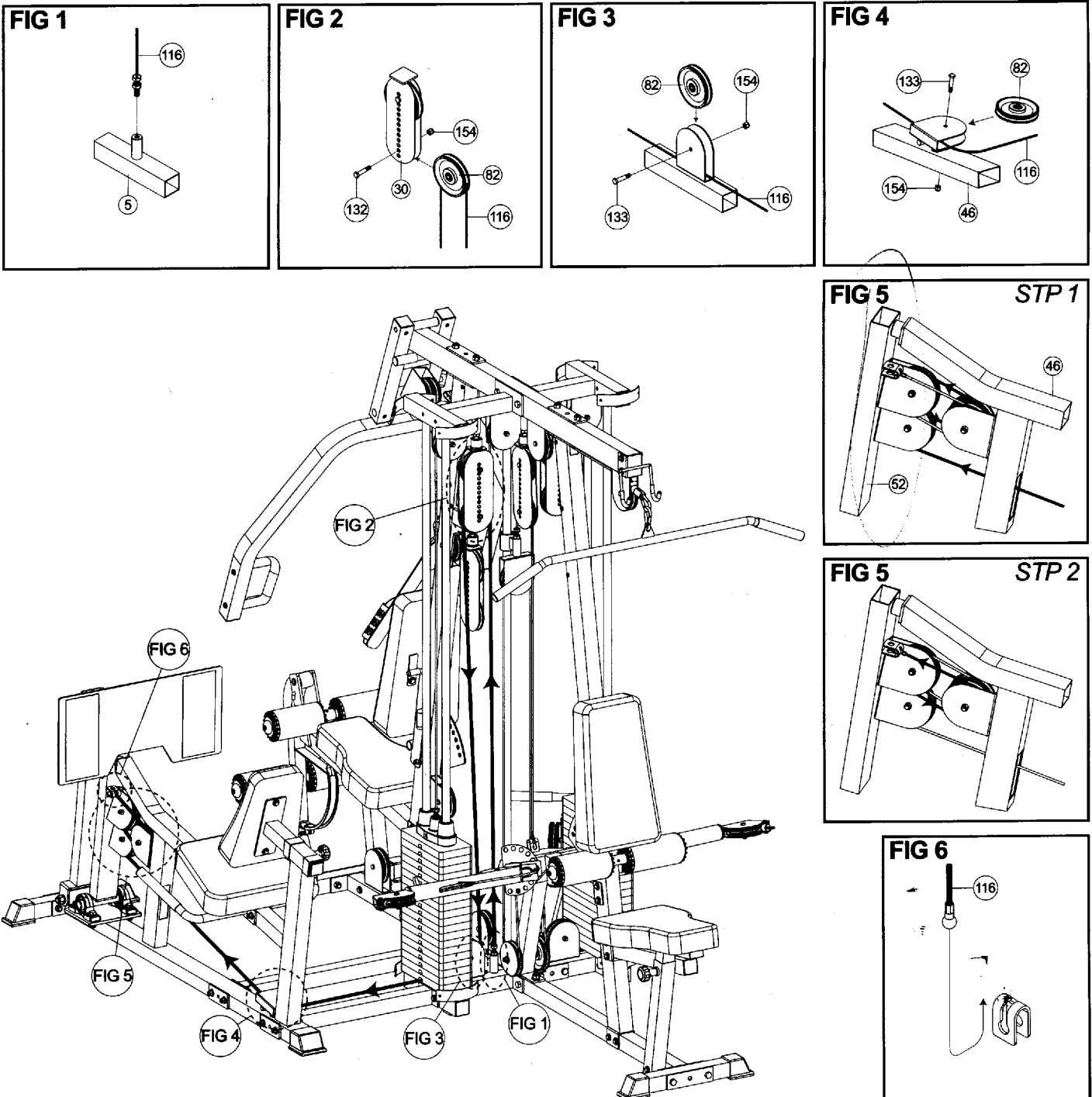

STEP 5 ASSEMBLE WEIGHT STACK SHROUDS AND POSTER PLATES

1. Attach Weight Stack Shrouds(32) to Weight Stack Bases(5, 6) and Tops using 5/16" Washers(148) and 5/16" X 1/2" Hex Head Bolts(135). Remember to keep all bolts loose in frame to ensure holes line up easily.
2. Attach Poster Plates(37, 38) to Rear and Front Uprights(3, 4) using 8 X 53mm Female Bolts(143) and 6 X 12mm Male Nuts(144).
3. Trim two Trims for Weight Shroud(108) on Weight Stack Shroud(32).

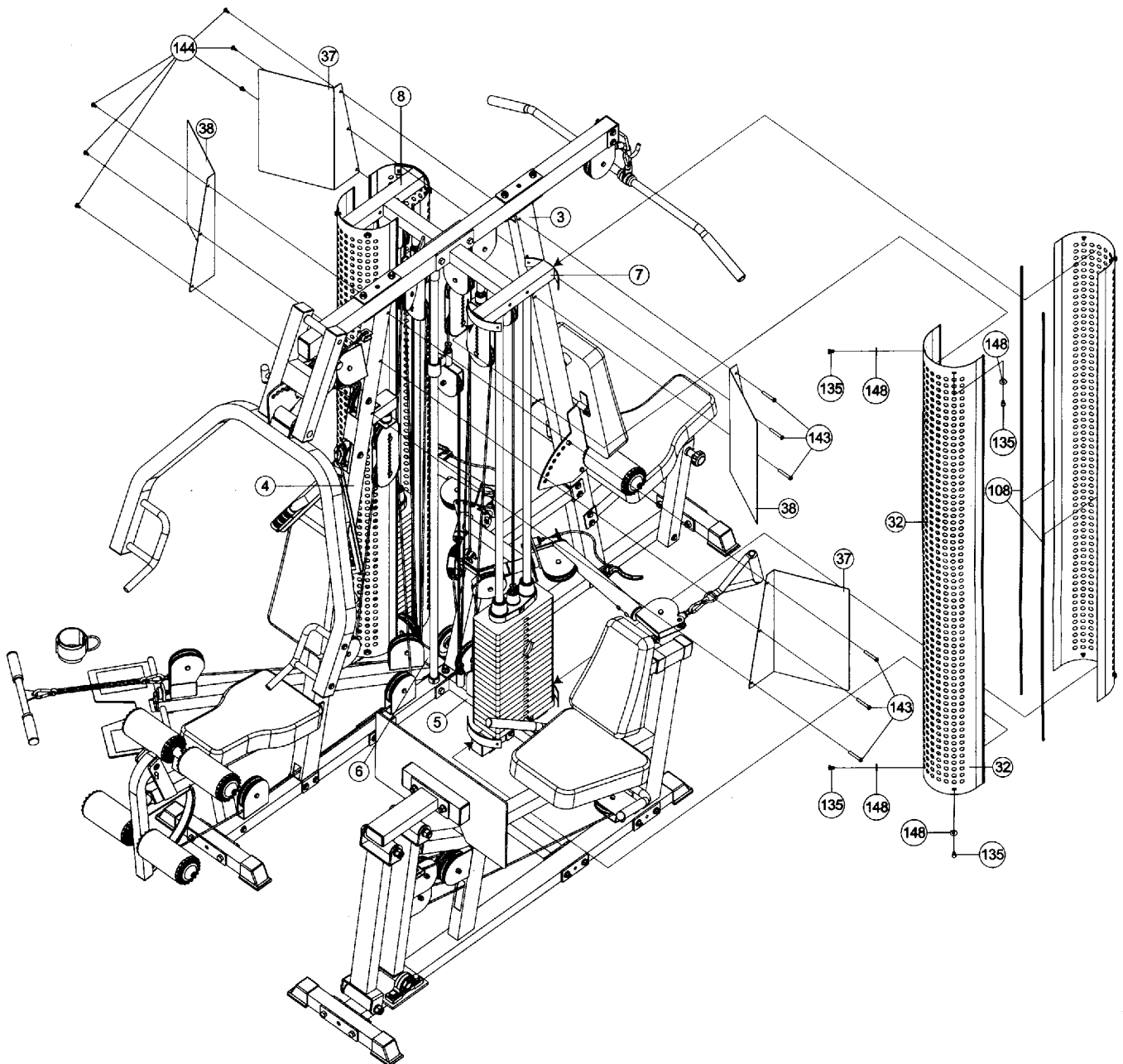

Assembly is complete! Please take the following steps before using the gym:

1. Make certain all bolts are tightened securely.
2. Make certain all cables are seated into all pulley grooves. A cable rubbing against steel will peel the nylon coating, voiding warranty and resulting in a need for replacement.
3. Pre-stretch the cables. Put the Weight Selector Pin (80) in the bottom hole on the weight stack. Pull on the cables with great force, helping remove any kinks and providing any initial cable stretch.
4. Be aware the cables can loosen and slightly stretch upon initial use.
5. The cables should be adjusted as tight as possible, but not so tight as to lift the Top Plate (96) above the weight stack. Be certain to secure the jam nuts after adjustments are made.
6. For better performance, apply a household lubricant (such as silicone) to any adjustable areas and to the Guide Rods (16).
7. Enjoy many years of a Fit Lifestyle.

Thank you for purchasing the Bodycraft Family ~~X~~_{PRO} Press Home Gym. If You have any questions, please call your local BodyCraft dealer or call our customer service department at 800-990-5556