



Congratulations on the purchase of your new DMI Sports Pool table. Our products are designed and manufactured to give you years of game playing enjoyment.

KEEP BOX AND PACKING MATERIAL UNTIL TABLE HAS BEEN COMPLETELY ASSEMBLED.

ALL DAMAGE MUST BE REPORTED TO DMI WITHIN TEN DAYS OF RECEIPT.

If you have any problems with your new product,

PLEASE DO NOT RETURN IT TO THE STORE.

Please contact us:

1.800.399.4402

FAX: 215.283.9573

Please have your model number when inquiring about parts.

Or write to:

DMI Sports

Customer Service

375 Commerce Drive

Fort Washington PA, 19034

Please visit our web site at:

www.dmisports.com

When contacting DMI Sports, please provide your model number and item number (if applicable) if requesting a replacement part. Item numbers can be found inside this owners manual.

Your Model Number **MFT450**

Your model number is also located on the original carton. These instructions are also available online at: www.dmisports.com.

IMPORTANT!

Please Keep Your Instructions! (You will need your Model number should you need to contact us.) Before attempting assembly, please read through this instruction book to familiarize yourself with all the parts and assembly steps. We recommend that two adults assemble this game. Please refer to the Parts Identifier on the following page and be sure that all parts have been included. Although we at DMI Sports are dedicated to giving our customers the highest quality products, occasionally a part may be missing. If you are missing a part, or if you have any questions, please call our customer service department at 1.800.399.4402 Mon - Fri between the hours of 9:00am and 5:00pm E.S.T; or you can reach us at: www.dmisports.com.

Do not return the game to the store. Please contact us first at: 1.800.399.4402 or on our website at: www.dmisports.com.











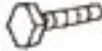

IT IS STRONGLY RECOMMENDED THAT THIS TABLE BE INSTALLED BY A PROFESSIONAL BILLIARD TABLE INSTALLER. THIS INSTRUCTION MANUAL DOES NOT INCLUDE INSTRUCTIONS FOR INSTALLING SLATE OR CLOTH.

DMI IS NOT RESPONSIBLE FOR DAMAGE THAT OCCURS DURING ASSEMBLY.

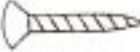
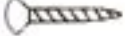















PARTS IDENTIFIER

HARDWARE PARTS

H1	Qty. 8	H2	Qty. 12	H3	Qty. 16	H4	Qty. 16
							
3/8" x 2.25" Bolt RPMFT450-3/8BLT		5/16" Washer RPMFT450-5/16WS		3/8" Nut RPMFT450-3/8NUT		3/8" x 2.5" Bolt RPMFT450-2.5BLT	
H5	Qty. 18	H6	Qty. 8	H7	Qty. 16	H8	Qty. 24
							
5/16" x 1.5" Bolt RPMFT450-1.5BLT		1/4" x 1.25" Bolt RPMFT450-1/4BLT		1/4" Washer RPMFT450-1/4WSH		T4 x .5" Screw RPMFT450-T4SCRW	
H9	Qty. 12	H10	Qty. 28	H11	Qty. 8	H12	Qty. 30
							
#12 x 2" Screw RPMFT450-#12		#8 x 1.25" Screw RPMFT450-#8		1/4" x 19MM Washer RPMFT450-19WASH		5/16" x 1.75" Bolt RPMFT450-5/16BT	
H13	Qty. 18	H14	Qty. 26	H15	Qty. 8	H16	Qty. 32
							
5/16" x 35MM Washer RPMFT450-35WASH		20MM Nail RPMFT450-20NAIL		1/4" x .5" Bolt RPMFT450-.5BOLT		3/8" x 25MM Washer RPMFT450-25WASH	

PARTS IDENTIFIER

ASSEMBLY PARTS

P1	Qty. 2	P2	Qty. 2	P3	Qty. 2	P4	Qty. 2
 Leg RPMFT450-LEG		 Side Apron RPMFT450-SIDEPANEL		 End Apron RPMFT450-ENDPANEL		 Side Top Rail RPMFT450-STRAIL	
P5	Qty. 2	P6	Qty. 2	P7	Qty. 1	P8	Qty. 2
 End Top Rail RPMFT450-ETRAIL		 End Slate RPMFT450-ESLATE		 Middle Slate RPMFT450-MSLATE		 End Plank RPMFT450-EPLANK	
P9	Qty. 2	P10	Qty. 2	P11	Qty. 4	P12	Qty. 4
 Side Plank RPMFT450-SPLANK		 Middle Plank RPMFT450-MPLANK		 Leg Leveler RPMFT450-LEV		 Apron Corner RPMFT450-APR	
P13	Qty. 4	P14	Qty. 6	P15			
 Corner Rail RPMFT450-CRAIL		 Basket Style Pocket RPMFT450-POCK		 Steel Sub-Frame RPMFT450-FRAME			

ASSEMBLY

STEP 1.

Install leg levelers.

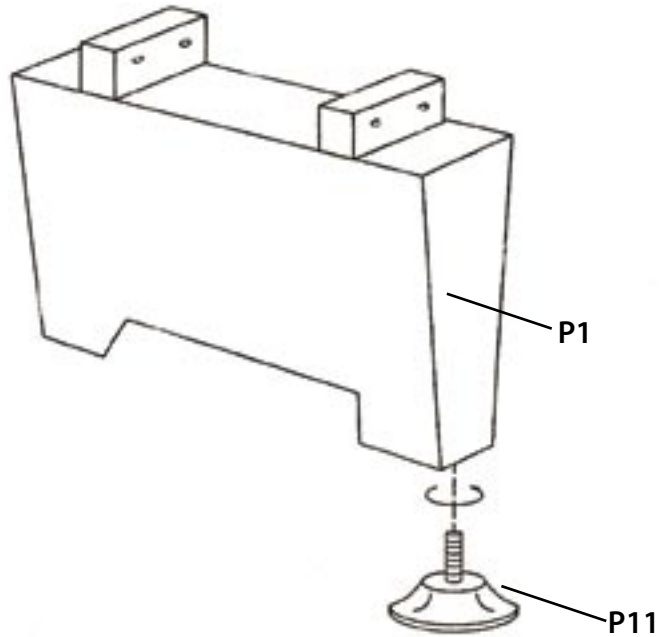

STEP 2.

Affix legs to Sub Frame and Steel Support Rail.

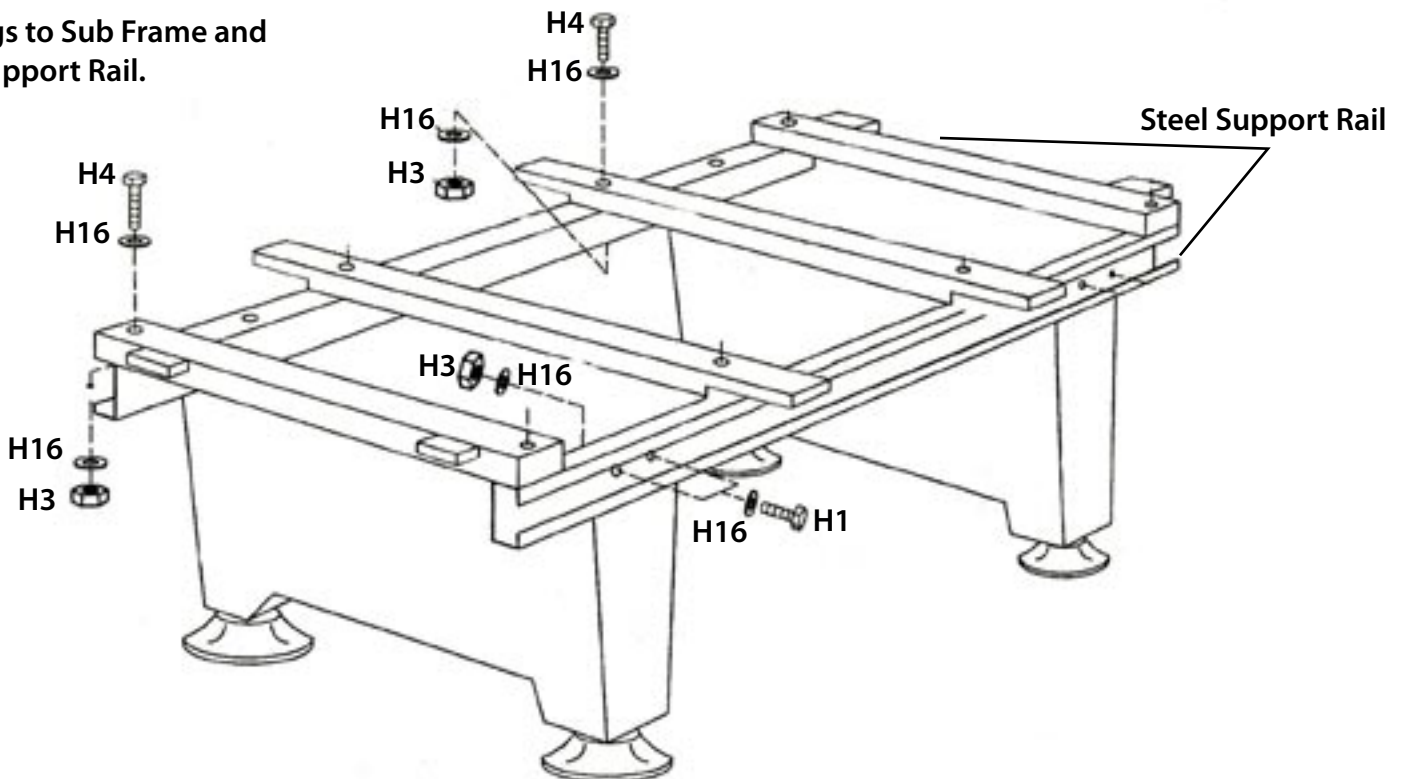

ASSEMBLY

STEP 3.

Attaching bed liner end supports to both ends.

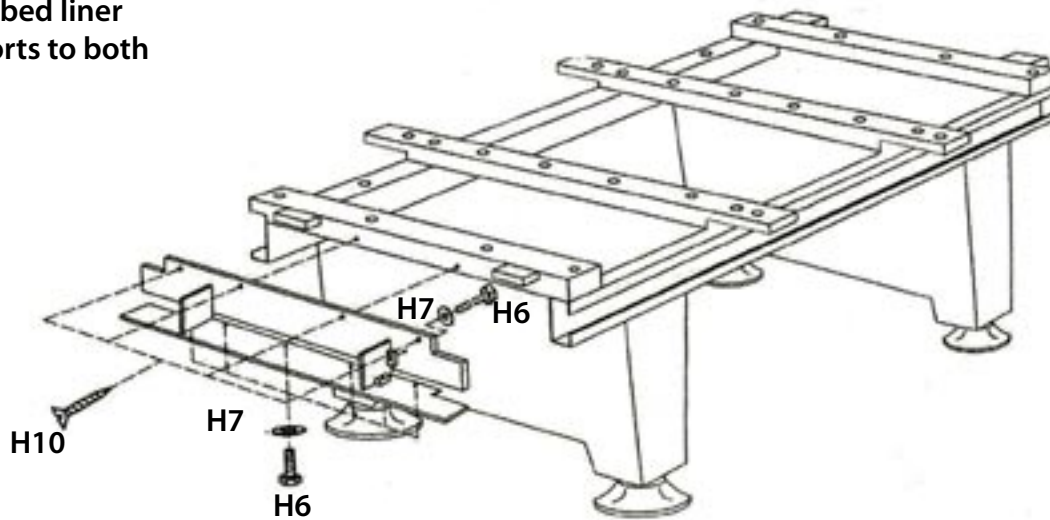

STEP 4.

Securing play surface bed liner.

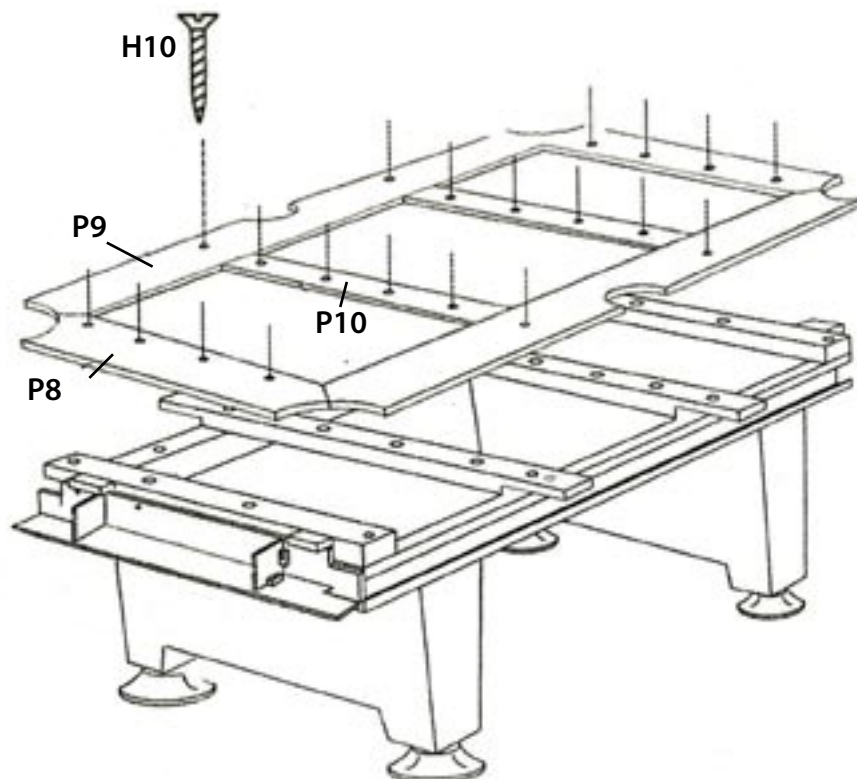

ASSEMBLY

STEP 5.

Attaching slate. Once slate has been aligned and secured, play surface cloth should be applied.

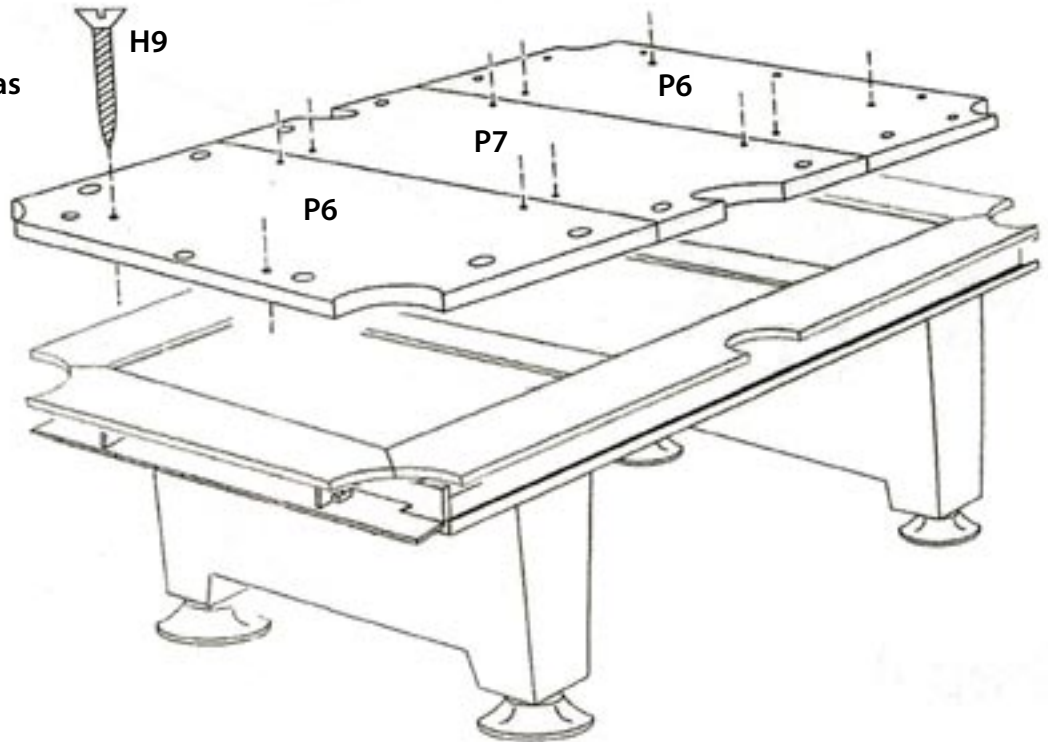

STEP 6.

Attach apron panels with plastic corner brackets.

For easiest installation, assemble top down.

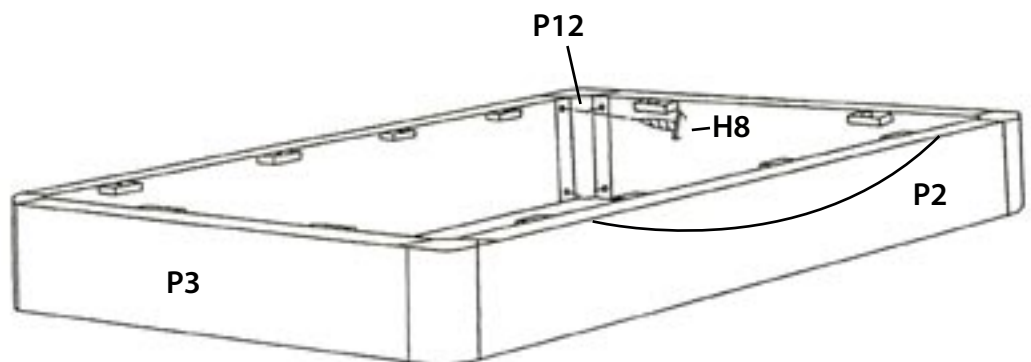

ASSEMBLY

STEP 7.

Attach rail assembly to apron assembly with chrome corner trim.

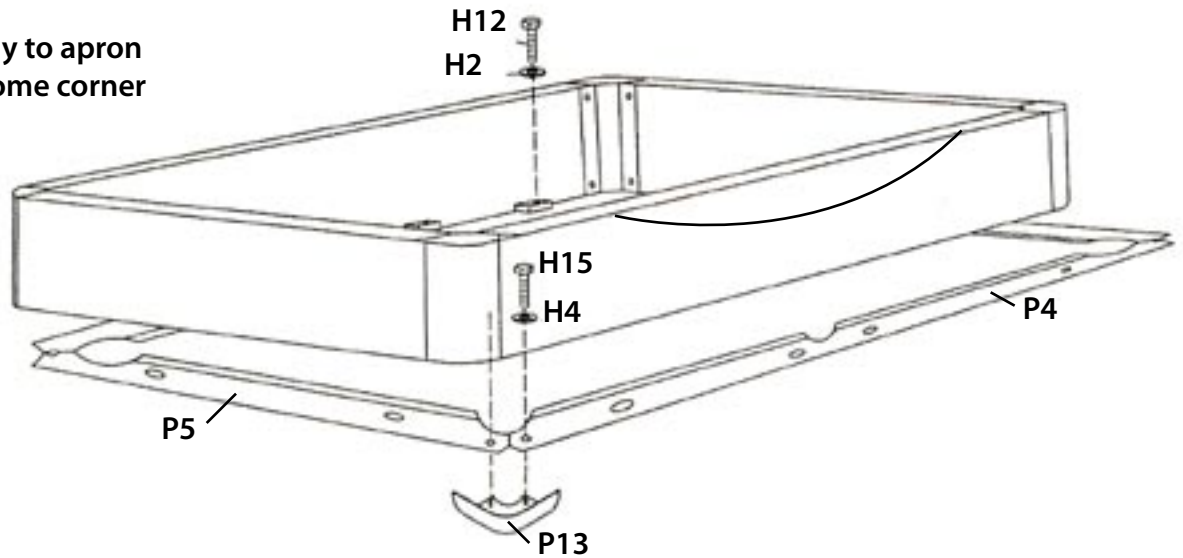

STEP 8.

Secure apron to cloth covered slate frame as shown here.

Tack pockets in place.

Use a level to make final adjustments to play surface.

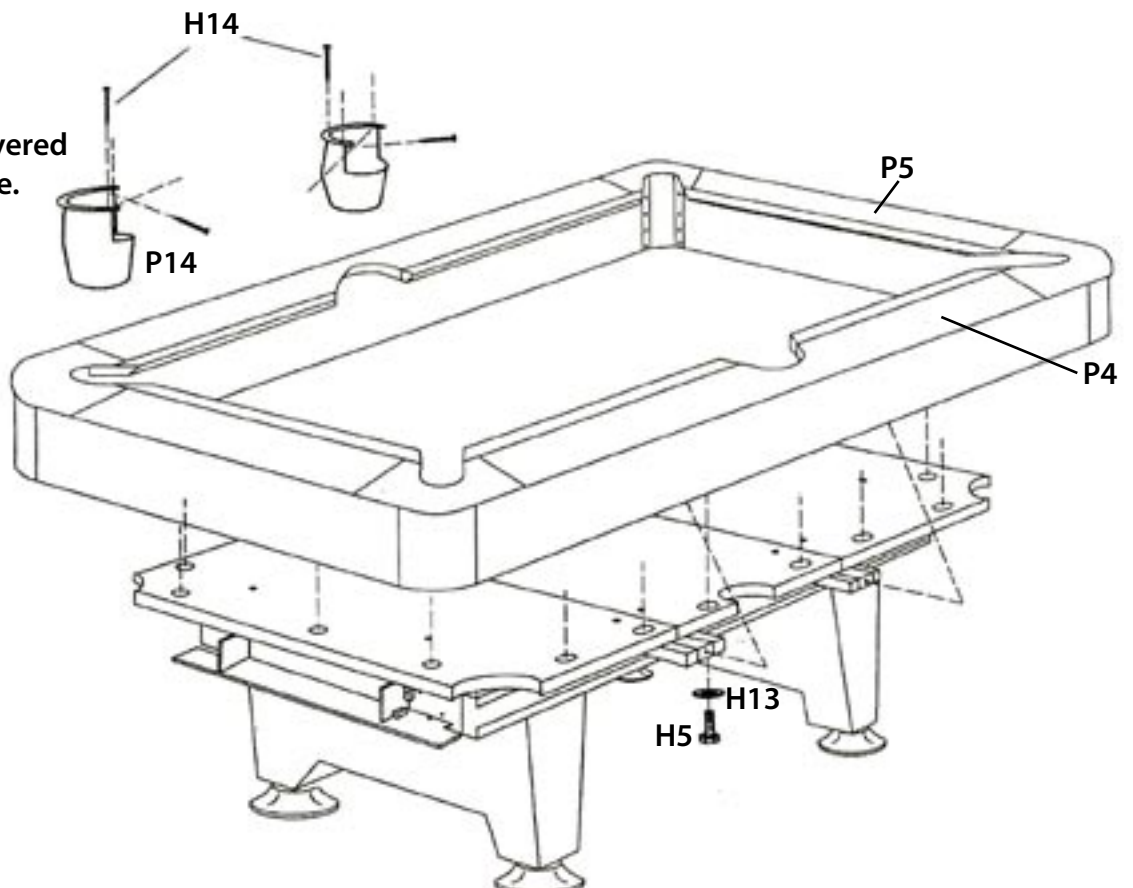

INSTRUCTIONS FOR LEVELING A POOL TABLE

- Assemble pool table according to the instructions, making sure levelers are screwed in completely, then turning one full turn out.
- Any type of level would be sufficient to perform this procedure. However, a two-foot level is recommended.
- Before leveling, make sure level is placed on the playing surface, not the rails.
- Level the ends between the corner pockets. Place the level on the playing surface between the two corner pockets and adjust the levelers in or out to position the bubble in the middle of the level.
- Repeat the step above to the opposite corner pockets.
- Next, level the length of the table. Place the level next to the side pocket and adjust the levelers in or out to position the bubble in the middle of the level.
- Repeat the step above to the opposite length of the table.
- Recheck both short ends to ensure bubble is in the middle on the level.
- Depending on the surface the pool table sits, especially deep pile carpeting, the pool table needs to settle for 24 hours. Recheck the level on each side of the table after 24 hours.
- These same instructions may be followed to level hockey and soccer table play surfaces as well.

PARTS RE-ORDER FORM

MFT450 Pool Table

Send this form along with your check or money order payable to:

DMI SPORTS

375 Commerce Drive
Fort Washington, PA 19034

www.dmisports.com

DATE: _____

NAME: _____

ADDRESS: _____ PHONE: _____

CITY: _____ STATE: _____ ZIP CODE: _____

REF	QTY	PART#	DESCRIPTION	UNIT PRICE	TOTAL AMOUNT
H1		RPMFT450-3/8BLT	3/8" x 2.25" Bolt (ea.)	.25	
H2		RPMFT450-5/16WS	5/16" Washer (ea.)	.25	
H3		RPMFT450-3/8NUT	3/8" Nut (ea.)	.25	
H4		RPMFT450-2.5BLT	3/8" x 2.5" Bolt (ea.)	.25	
H5		RPMFT450-1.5BLT	5/16" x 1.5" Bolt (ea.)	.25	
H6		RPMFT450-1/4BLT	1/4" x 1.25" Bolt (ea.)	.25	
H7		RPMFT450-1/4WASH	1/4" Washer (ea.)	.25	
H8		RPMFT450-T4SCRW	T4 x .5" Screw (ea.)	.35	
H9		RPMFT450-#12	#12 x 2" Screw (ea.)	.35	
H10		RPMFT450-#8	#8 x 1/25" Screw (ea.)	.35	
H11		RPMFT450-19WASH	1/4" x 19mm Washer (ea.)	.25	
H12		RPMFT450-5/16BT	5/16" x 1.75" Bolt (ea.)	.25	
H13		RPMFT450-35WASH	5/16" x 35mm Washer (ea.)	.25	
H14		RPMFT450-20NAIL	20mm Nail (ea.)	.10	
H15		RPMFT450-.5BOLT	1/4" x .5" Bolt (ea.)	.25	
H16		RPMFT450-25WASH	3/8" x 25mm Washer (ea.)	.25	
P1		RPMFT450-LEG	Leg (ea.)	35.00	
P2		RPMFT450-SIDEPANEL	Side Panel (ea.)	25.00	
P3		RPMFT450-ENDPANEL	End Panel (ea.)	20.00	
P4		RPMFT450-STRAIL	Side Top Rail (ea.)	20.00	
P5		RPMFT450-ETRAIL	End Top Rail (ea.)	15.00	
P6		RPMFT450-ESLATE	End Slate (ea.)	90.00	
P7		RPMFT450-MSLATE	Middle Slate (ea.)	90.00	
P8		RPMFT450-EPLANK	End Help Plank (ea.)	15.00	
P9		RPMFT450-SPLANK	Side Help Plank (ea.)	15.00	
P10		RPMFT450-MPLANK	Middle Help Plank (ea.)	15.00	
P11		RPMFT450-LEV	Leg Leveler (ea.)	10.00	
P12		RPMFT450-APR	Apron Corner (ea.)	15.00	
P13		RPMFT450-CRAIL	Rail Corner (ea.)	15.00	
P14		RPMFT450-POCK	Basket Style Pocket (ea.)	10.00	
		RPMFT450-KIT	Hardware Kit (1/2) (ea.)	12.50	

SHIPPING AND HANDLNG:

Subtotal:

Up to \$15.00 add \$2.00 for S&H

PA Residents Add 6% State Sales Tax:

Over \$15.00 CALL

Shipping and Handling Charges:

TOTAL: