



OWNER'S MANUAL



 **Polaris 165/Super Turtle**
 **Polaris 65/Turbo Turtle**

IMPORTANT INFORMATION

SERIAL NUMBER

Important Information

- Always disconnect the Polaris from the pool wall when cleaning or backwashing the pool filter.
- After cleaning or backwashing, let the filtration system run for at least five minutes before re-connecting the Polaris.
- New plumbing lines should be flushed out before installing the Polaris.
- Do not handle the Polaris while it is operating.
- Always remove the Polaris **before swimmers enter the pool**.
- Always remove the Polaris from the pool before chemical shock treatments.

For customer service or support:

- Please mail Warranty Card immediately.
- For on-line support: www.polarispool.com
- To contact Polaris:

US and Canada

Customer Service
2620 Commerce Way
Vista, CA 92081-8438
1-800-822-7933

Australia

Unit 4, 19-21 Gibbes Street,
Chatswood, NSW 2067
1-300-POLARIS
ACN 080 168 092

Europe

C/Osana s/n.
(Pol.End.El Ramassar),
98520 Les Franqueses del Vallés
Barcelona, Spain
+34 93 840 25 85

Polaris Limited Warranty

This one year limited warranty is extended to the original consumer purchaser of this Polaris Vac-Sweep® 65/ Polaris Turbo Turtle®, Polaris Vac-Sweep® 165 / Polaris Super Turtle® Automatic Pool Cleaner manufactured by Polaris Pool Systems, Inc., from date of manufacture of the unit as established by the serial number, or one year from date of purchase with proof of purchase, whichever is later. Polaris warrants this product, including all parts and components thereof, to be free of defects in material and workmanship. Normal replacement items such as the filter bag, which have been worn out by use or improper installation are not covered by this warranty. The Polaris 65/Turbo Turtle, Polaris 165/Super Turtle bottom is warranted for a period of three years.

This limited warranty does not apply if the failure is caused or contributed to by any of the following: improper handling, improper usage, improper storage, winter freezing, abuse, improper installation, removal of the UWF filter screen, unsuitable application of the unit, improper maintenance, lack of reasonable and necessary maintenance, damage in transit or during installation, or damage from repairs/alterations made or attempted by anyone other than Polaris or one of its Authorized Service Centers. In no event shall Polaris be liable for incidental or consequential damages of any nature or for damages to persons or property, including damage to vinyl liners, plaster, tile, aggregate-based and other pool surfaces, or damages resulting from the use of this product with a substandard pool circulation system or a chemical imbalance.

Authorization to return a unit or part to the plant of manufacture must be obtained from the Polaris Customer Service Department. Check with your dealer for the local procedure before exercising this warranty. If further directions or instructions should be required, contact the Customer Service Department at 1-800-VAC-SWEEP (USA and Canada only) or (760) 599-9600. Be sure to insure the shipment against loss or damage in transit.

This limited warranty is valid only in the United States of America, Canada and Australia, and it does not apply to Polaris 65/Turbo Turtle, 165/Super Turtle Automatic Swimming Pool Cleaners sold or installed in any other country. Polaris 65/Turbo Turtle, 165/Super Turtle Automatic Pool Cleaners sold in the United Kingdom are warranted for a period of two years from date of invoicing to the first user.

WARNING: USE OF POLARIS 65/TURBO TURTLE, 165/SUPER TURTLE IN A VINYL LINER POOL

Certain vinyl liner patterns are particularly susceptible to rapid surface wear or pattern removal caused by objects coming into contact with the vinyl surface, including pool brushes, pool toys, floats, fountains, chlorine dispensers, and automatic pool cleaners. Some vinyl liner patterns can be seriously scratched or abraded simply by rubbing the surface with a pool brush. Ink from the pattern can also rub off during the installation process or when it comes into contact with objects in the pool. Polaris is not responsible for, and the Limited Warranty does not cover, pattern removal, abrasion or markings on vinyl liners.

U.S. Patents: 4,994,178; 5,014,912; 2,860,058; RE34,301 and other patents pending.

Foreign Patents: 610,303; 614,334; 615,498; 0,319,341; 0,319,342; 0,329,472; 1,307,881; 1,314,118; 1,335,166; P3871917.7.

Introduction

Congratulations on the purchase of your new automatic pool cleaner, and thank you for choosing Polaris. The Polaris 65/Turbo Turtle for aboveground pools and the Polaris 165/Super Turtle for in-ground vinyl or fiberglass pools are designed to give you years of dependable and efficient service.

Like most mechanical devices, these cleaners will require periodic adjustments, routine maintenance, and the replacement of certain hardworking parts. Please have your cleaner checked occasionally by your local Polaris dealer or authorized service center.

Always insist on genuine Polaris replacement parts. Non-Polaris parts are not made to our specifications. They may have an adverse effect on the operation of your Polaris or may even damage it.

Polaris Complete Cleaner

- | | |
|--------------------------------------------------------------------|--------------------------------------------------------|
| 1a. Surface Module | 7. Float Hose |
| 1b. Turtle Top | 8. Quick Disconnect |
| 2. Wheel Cage | 9. Universal Wall Fitting (UWF) |
| 3. Sweep Hose | 10. Eyeball Regulators (2) – 165 and Super Turtle only |
| 4. Jet Sweep Assembly | |
| 5. All-Purpose Bag | |
| 6. Float Hose Extension with Connector – 165 and Super Turtle only | |

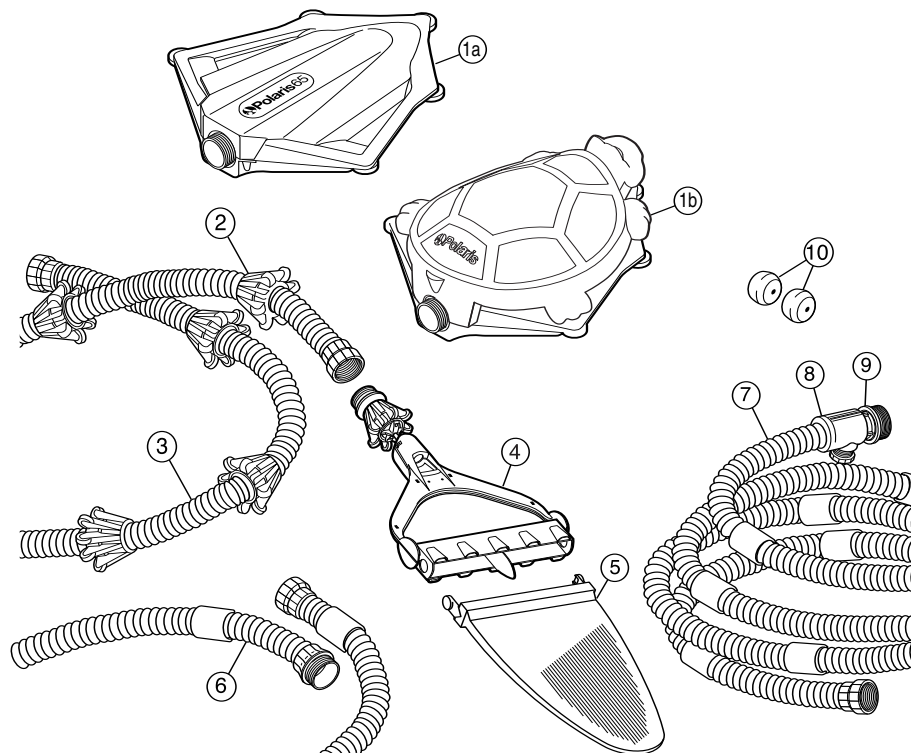

Quick Installation Instructions

Three quick steps to install and get maximum performance from the Polaris:

- Install the Universal Wall Fitting (UWF) with Quick Disconnect
- Adjust sweep hose to fit pool depth
- Adjust float hose to fit pool length

1

Install the Universal Wall Fitting

Installs in minutes on pools with a 1-1/2" female threaded return line.

1. Turn on the filtration pump and flush out the plumbing line. Turn pump off.
2. **Polaris 165/Super Turtle Only** — Use the return line nearest the center point of the longest pool wall for the Polaris. If there are two, choose the return line closest to the pool equipment. Place the eyeball regulator disks into the remaining return lines.
3. Remove the UWF from the Quick Disconnect and screw the UWF into the return opening.
4. Turn the Quick Disconnect clockwise into the UWF and pull away to secure.

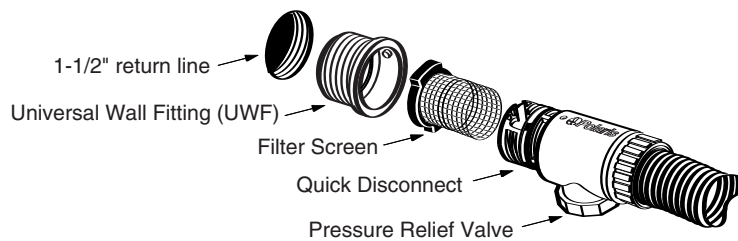

If the return line has either of the fittings diagrammed below, remove the parts as shown and then install the UWF.

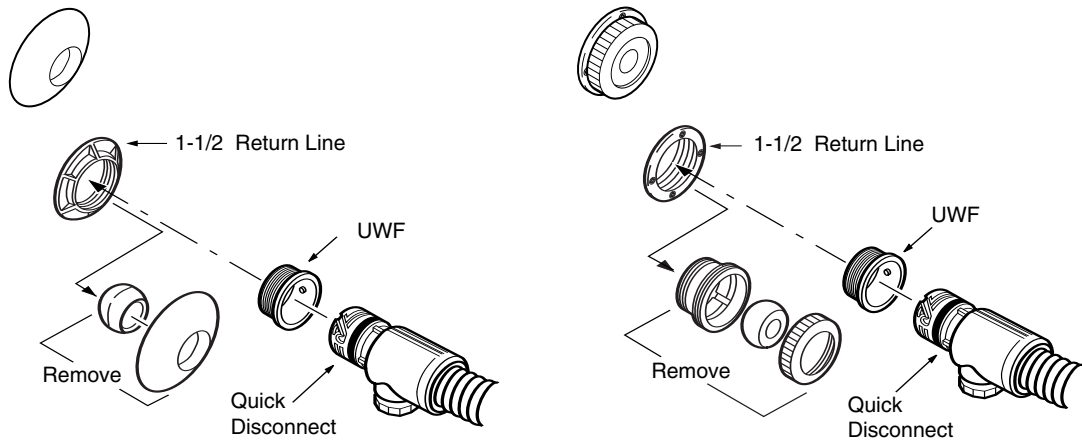

If the return line is a 1-1/4" or 2" eyeball fitting, order Polaris Adapter Kit (part #6-510-00) from an authorized Polaris dealer. If the return line differs from all of these, contact Polaris for assistance.

2

Adjust Sweep Hose to Fit Pool Depth

1. Measure the deepest part of the pool. Add two feet to this measurement to determine the correct length for the sweep hose.
2. If the sweep hose is longer than the measured amount, cut off the excess hose.
3. Remove the hose connector from the excess hose piece just cut.
4. Use fingers to collapse sweep hose. Push hose into connector until the first groove is inside.
5. Slide fingers inside hose, through connector, and pop hose back to original shape.

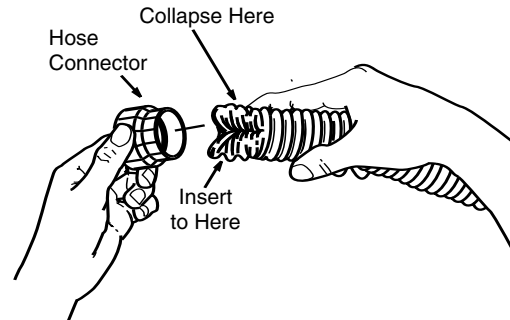

3

Adjust Float Hose to Fit Pool Length

With float hose attached to the pool wall at the return line, extend the hose to the farthest point of the pool. The end of the hose should be 4 feet shorter than this point.

Hose too long? Cut the excess float hose. Remove the hose connector from the excess hose piece and attach it to the new end of the float hose as instructed above.

Hose too short? For **Polaris 165/Super Turtle** only, add the float hose extension between the existing float hose section and the surface module. Remeasure and adjust as necessary.

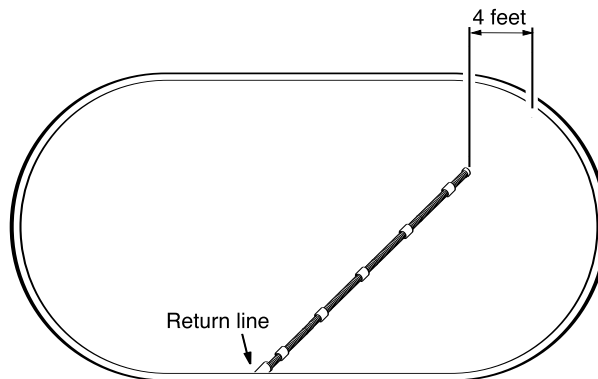

1. Open the frame of filter bag completely and attach it to jet sweep assembly. Attach assembly to sweep hose.
2. Attach float hose and sweep hose to the surface module.
3. Put the Polaris in the pool and turn on the pool filtration pump.
4. Extend the float hose to the farthest point in the pool. When the pool pump is running, the **surface module should be approximately one foot from the pool wall.**

Fine Tuning the Polaris Cleaner

When operating correctly, the Polaris vacuums and sweeps all surfaces, moving randomly throughout the pool. The surface module floats on the water's surface recirculating clean, filtered water. The sweep hose and filter bag move across the pool floor collecting dirt and debris.

Approximately every 15-25 seconds the Polaris will change directions.

Pressure Relief Valve

The pressure relief valve in the Quick Disconnect automatically releases water if the Polaris is receiving too much water pressure. It can also be used to regulate the movement of the cleaner.

If the Polaris changes directions too quickly, adjust the pressure relief valve to slow the cleaner.

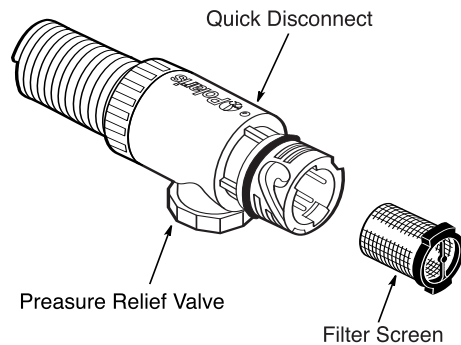

Routine Maintenance

Cleaning the Filter Bag

Depress the buttons on the jet sweep assembly to release the bag. Turn the filter bag inside-out to remove the debris.

Open frame completely and reattach bag.

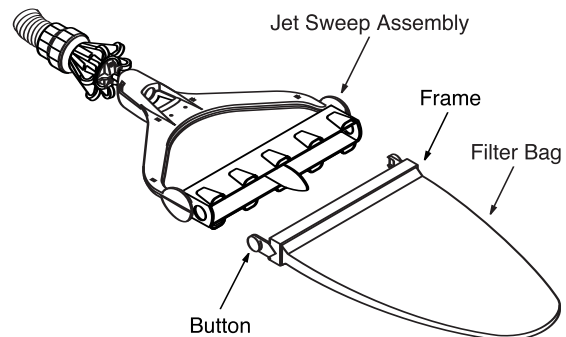

Cleaning the Filter Screen

The filter screen inside the Quick Disconnect captures debris missed by the pool filtration system. To clean, pull it out, rinse it and press it back into place.

Backwashing the Pool Filter

Always disconnect the Polaris from the pool wall before cleaning or backwashing the pool filter. After cleaning or backwashing, let the filtration system run for at least five minutes to flush out the return lines before re-connecting the Polaris.

Storage and Winterizing

Never store the Polaris in direct sunlight. When storing for the winter, drain out all the water (freeze damage is not covered under the warranty). Remove the sweep jet assembly from the sweep hose and store it flat. Hang or lay the hoses straight. Remove all fittings from the return lines including the UWF. In some cases, it may be necessary to use the UWF Removal Tool (part #10-102-00) available from an authorized Polaris dealer.

Troubleshooting

If the Polaris cleaner regularly displays the following actions, adjustments may be necessary to restore performance. Refer to exploded parts diagram for part references.

Action: Polaris does not clean the entire pool or runs slowly.

- Solution:
1. Verify that the pressure relief valve is releasing water. If it is not, clean or backwash the pool filter.
 2. Check the filter screen in the quick disconnect and clean if necessary.
 3. Verify that the float hose is the proper length.
 4. Remove the surface module top. With the Polaris operating, verify that the randomizer tube is moving back and forth.

If it is **not moving**: Turn off pump, disconnect hoses, look into the mechanism and locate the filter connector inside the randomizer tube. If it is covered with debris or algae, remove the connector chamber, cylinder, and piston. Pull out the randomizer tube and clean the filter connector. If the connector is clean, replace the piston.

If it is **moving**: Watch the randomizer ball in the mechanism. If it does not move within 2 minutes, replace the randomizer tube and piston.

5. Verify that the water pressure is between 5 and 10 psi. A pressure tester (part #6-113-00) is available through your participating Polaris dealer.

Action: Surface module dives under the water or leans to one side.

- Solution:
1. Straighten twisted hoses.
 2. Lift surface module out of the water, empty it and then shake it. If water is still heard inside, remove the top, pull out the drain plug assembly and drain the module.
 3. Adjust the pressure relief valve until the surface module levels off.
 4. Verify that the water pressure is between 5 and 10 psi. A pressure tester (part #6-113-00) is available from an authorized Polaris dealer.

Action: The float hose remains coiled.

- Solution:
1. See “Polaris does not clean entire pool.”
 2. Lay the float hose out straight in the sun to remove the coils.

Action: Surface module moves too fast.

- Solution:
1. Adjust the pressure relief valve until the surface module slows down.
 2. **165/Super Turtle only:** Remove one of the eyeball regulators and readjust the pressure relief valve if necessary.
 3. Verify that the water pressure is between 5 and 10 psi.

Action: Bag does not stay on the pool floor.

- Solution:
1. Verify that the bag has been installed correctly.
 2. Check for air bubbles around the jet body assembly. This may indicate air in the plumbing lines.
 3. See “Surface module moves too fast.”

Polaris165/SuperTurtle

Exploded Parts Diagram

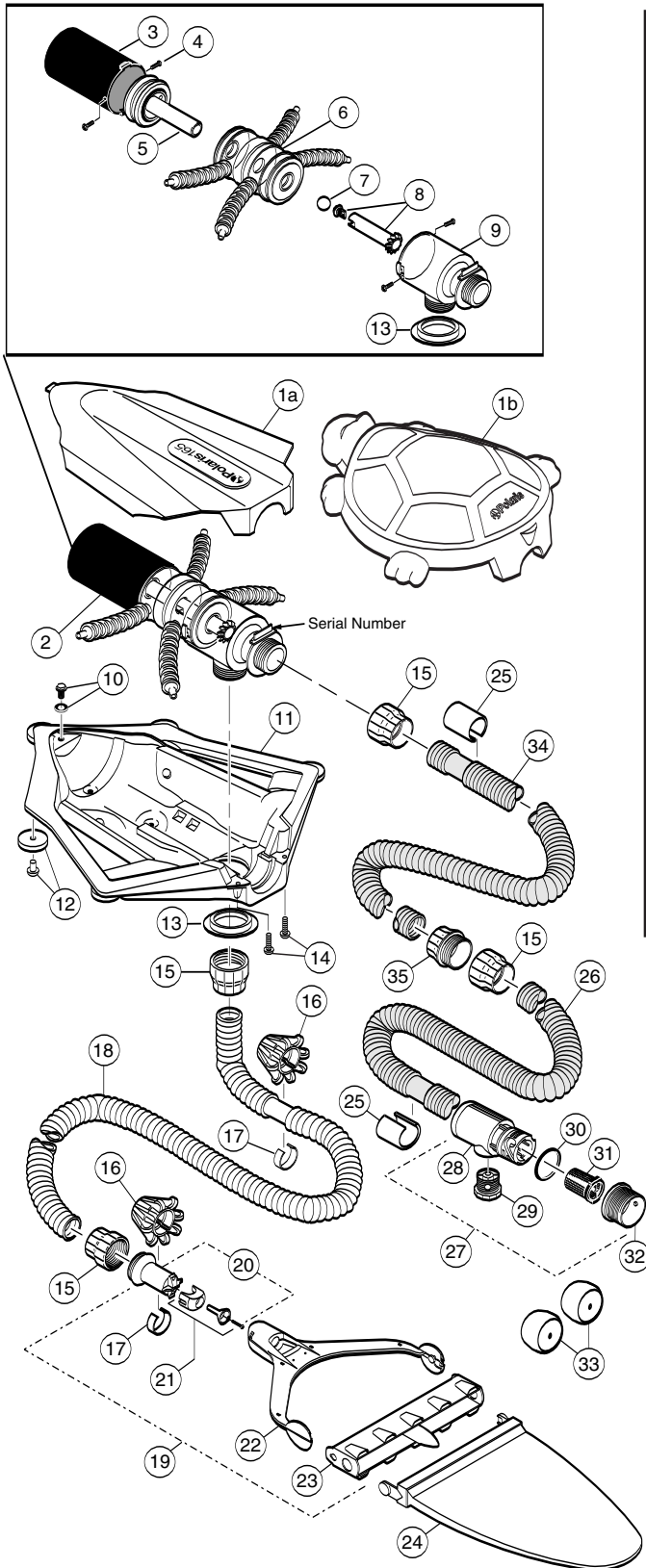

No.	Part #	Description	Qty.
1a	6-306-00	Surface Module Top, Granite	1
1b	6-309-00	Turtle Top	1
2	6-400-00	Mechanism	1
3	6-407-00	Cylinder	1
4	6-413-00	Screw, Mechanism, #6 x 5/16" SS Sheet Metal, Blunt-end	4
5	6-411-00	Piston Assembly	1
6	6-409-00	Center Chamber Assy	1
7	6-403-00	Randomizer Ball	1
8	6-406-00	Filter Connector/Randomizer Tube Kit	1
9	6-408-00	Connector Chamber	1
10	6-507-00	Drain Plug Assembly	1
11	6-305-00	Body Bottom Assembly	1
12	6-301-00	Body Bottom Wheel Kit	5
13	**	Support Collar	1
14	6-302-00	Screw, Top, #10 x 3/4" SS Sheet Metal, Pan Head	2
15	6-104-00	Hose Connector, Female	4
16	6-107-00	Wheel Cage Assembly	9
17	6-110-00	Hose Weight	9
18	6-114-00	Sweep Hose Complete, 10 Ft.	1
19	6-212-00	Jet Sweep Assembly	1
20	6-116-00	Jet Body Assembly	1
21	6-119-00	Jet Body Ball Kit	1
22	6-211-00	Jet Sweep Harness	1
23	6-210-00	Jet Sweep Head	1
24	6-206-00	All-Purpose Bag*	1
25	6-222-00	Float	24
26	6-225-00	Float Hose, 24 Foot (Hose only)	1
27	6-508-00	UWF Connector Assembly	1
28	6-502-00	Quick Disconnect, UWF	1
29	6-503-00	Pressure Relief Valve	1
30	6-505-00	O-ring, UWF/QD	1
31	6-504-00	Filter Screen, UWF/QD	1
32	6-500-00	Universal Wall Fitting (UWF)	1
33	10-107-00	Eyeball Regulator	2
34	6-221-00	Float Hose Extension Kit, 8 Ft	1
35	6-103-00	Hose Connector, Male	1

* Wear items not covered by warranty.

Polaris 65/TurboTurtle

Exploded Parts Diagram

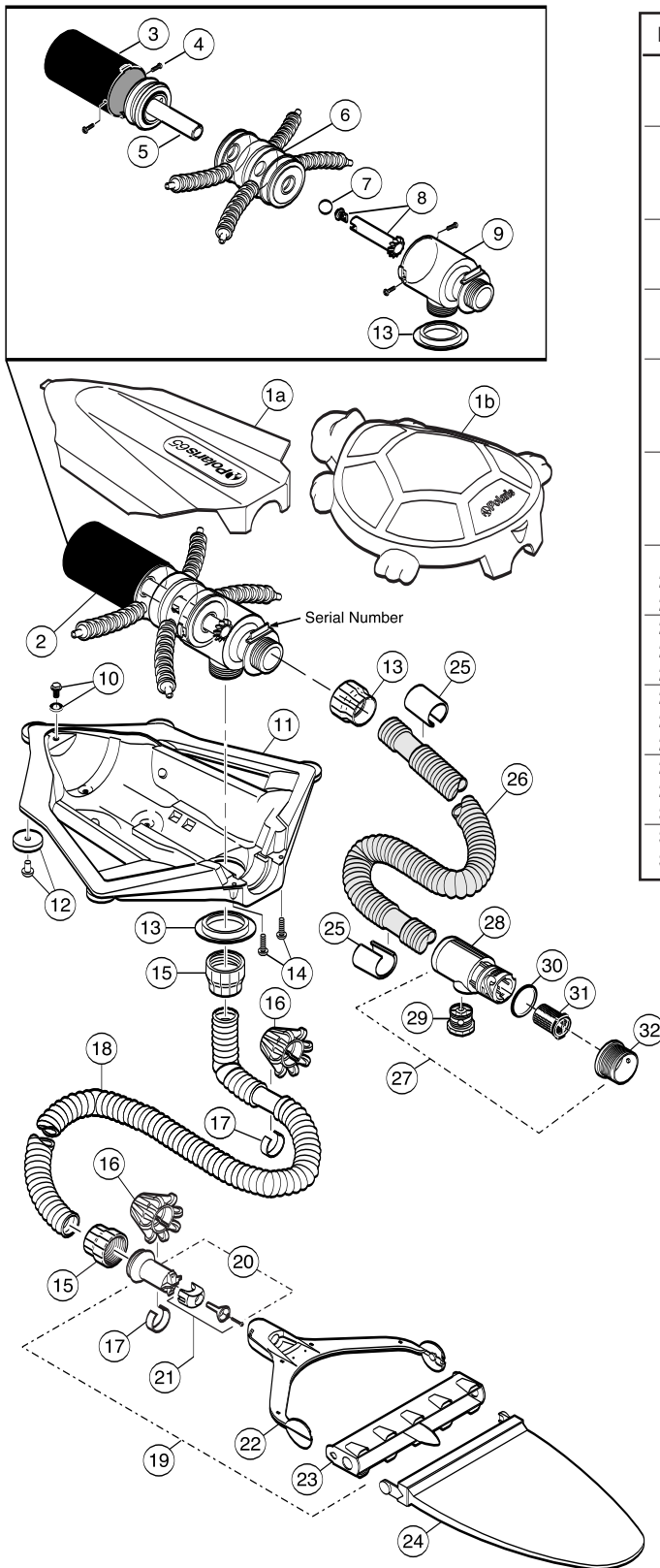

No.	Part #	Description	Qty.
1a	6-308-00	Surface Module Top, Blue	1
1b	6-309-00	Turtle Top	1
2	6-400-00	Mechanism	1
3	6-407-00	Cylinder	1
4	6-413-00	Screw, Mechanism, #6 x 5/16" SS Sheet Metal, Blunt-end	4
5	6-411-00	Piston Assembly	1
6	6-409-00	Center Chamber Assy	1
7	6-403-00	Randomizer Ball	1
8	6-406-00	Filter Connector/Randomizer Tube Kit	1
9	6-408-00	Connector Chamber	1
10	6-507-00	Drain Plug Assembly	1
11	6-305-00	Body Bottom Assembly	1
12	6-301-00	Body Bottom Wheel Kit	5
13	**	Support Collar	1
14	6-302-00	Screw, Top, #10 x 3/4" SS Sheet Metal, Pan Head	2
15	6-104-00	Hose Connector, Female	3
16	6-107-00	Wheel Cage Assembly	6
17	6-110-00	Hose Weight	6
18	6-106-00	Sweep Hose Complete, 7 Ft.	1
19	6-212-00	Jet Sweep Assembly	1
20	6-116-00	Jet Body Assembly	1
21	6-119-00	Jet Body Ball Kit	1
22	6-211-00	Jet Sweep Harness	1
23	6-210-00	Jet Sweep Head	1
24	6-206-00	All-Purpose Bag*	1
25	6-222-00	Float	24
26	6-225-00	Float Hose, 24 Foot	1
27	6-508-00	UWF Connector Assembly	1
28	6-502-00	Quick Disconnect, UWF	1
29	6-503-00	Pressure Relief Valve	1
30	6-505-00	O-ring, UWF/QD	1
31	6-504-00	Filter Screen, UWF/QD	1
32	6-500-00	Universal Wall Fitting (UWF)	1

*Wear items not covered by warranty.