

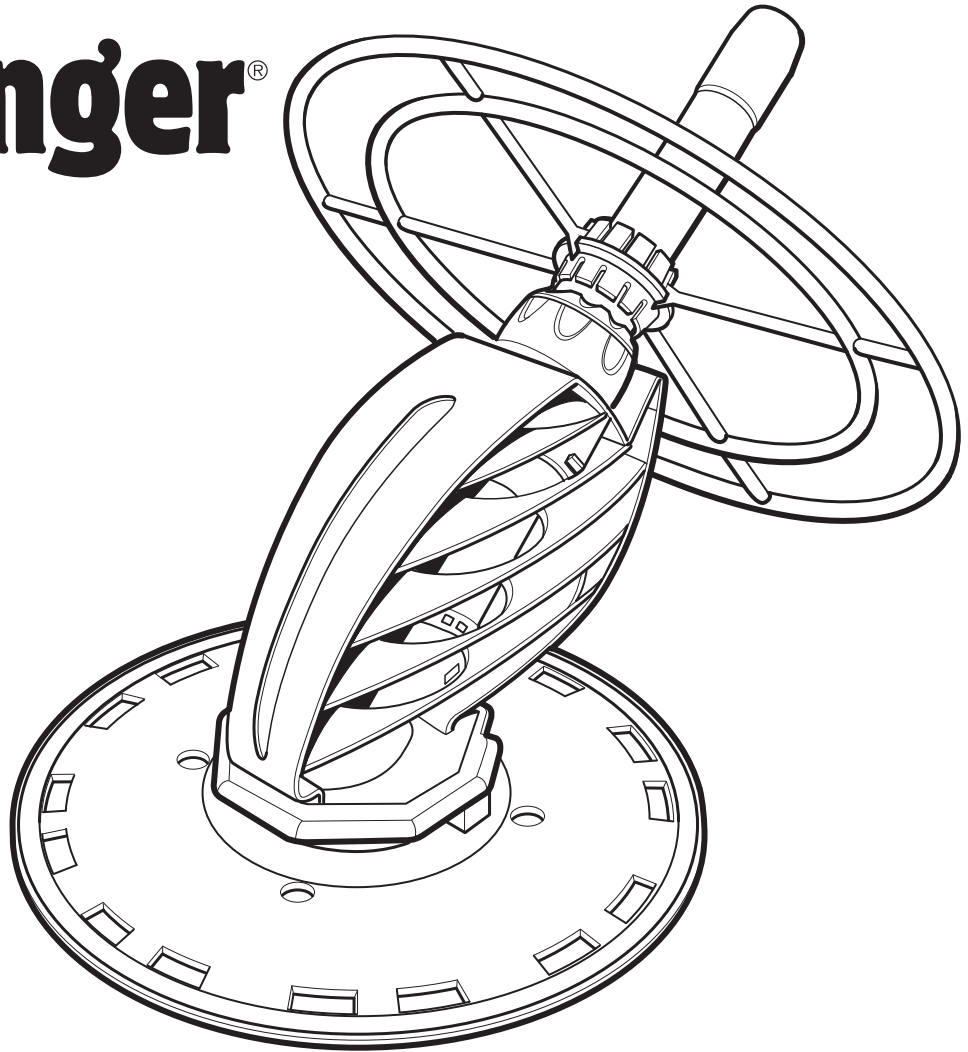

ZODIAC

Ranger®

OWNER'S MANUAL



The following parts are included with your Ranger (Model# W01698):

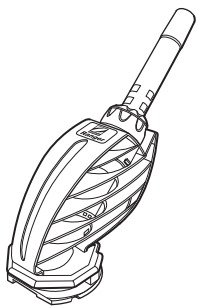

(1) Cleaner Head

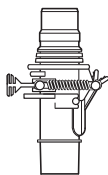

(1) FlowKeeper™ Valve

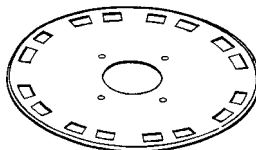

(1) Slotted Disc

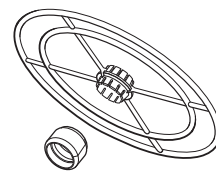

(1) Wheel Deflector & Adapter



(10) Hose Lengths



(1) 4 1/2" Connector



(1) Aboveground Valve Cuff



(1) 45 Degree Elbow

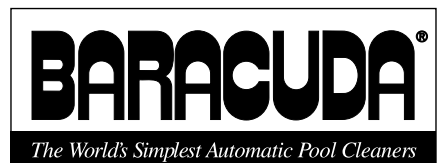

THANK YOU FOR PURCHASING RANGER®.
**YOUR RANGER HAS BEEN DESIGNED AND MANUFACTURED TO BE EASILY
INSTALLED AND TO PROVIDE YEARS OF LOW MAINTENANCE OPERATION.**
PRIOR TO INSTALLING YOUR NEW RANGER, PLEASE DO THE FOLLOWING:

- 1) Complete and return the warranty card.
- 2) Record your purchase information on the spaces provided below.
- 3) Attach your invoice (or a copy) to this page.

These actions will insure prompt warranty service, should it be required. Simply present your owner's manual, along with the invoice at any of our authorized warranty centers nationwide.

RECORD YOUR RANGER POOL CLEANER DATA HERE:

Date of Purchase _____ Purchased From _____ Serial Number: _____
(located on underside of machine head)

City _____ State _____ Zip Code _____

RANGER LIMITED WARRANTY

This RANGER was carefully inspected before shipment from our warehouse. Upon unpacking, if any part proves defective or missing, please notify Zodiac Pool Care, Inc. immediately. Please consult owner's manual for complete instructions on the installation and operation of your RANGER.

ZODIAC POOL CARE, INC. WARRANTS THE RANGER POOL CLEANER AGAINST ALL MANUFACTURING DEFECTS AND ALL WEAR AND TEAR FOR (1) YEAR. ALL WARRANTIES ARE EFFECTIVE FROM THE DATE OF PURCHASE.

Should this product prove defective in workmanship, materials or wear during the applicable warranty period, the consumer's sole and exclusive remedy shall be such repair or replacement of the product as provided below.

THE LIMITED WARRANTY PROVIDED HEREIN IS THE SOLE AND EXCLUSIVE WRITTEN WARRANTY WITH RESPECT TO THE RANGER POOL CLEANER. ALL IMPLIED WARRANTIES IMPOSED BY APPLICABLE LAW, INCLUDING ANY IMPLIED WARRANTY OF MERCHANTABILITY OR FITNESS FOR A PARTICULAR PURPOSE, ARE LIMITED TO THE DURATION OF THE EXPRESS LIMITED WARRANTY. SOME STATES DO NOT ALLOW LIMITATIONS ON HOW LONG AN IMPLIED WARRANTY LASTS, SO THE ABOVE LIMITATION MAY NOT APPLY TO YOU.

THIS LIMITED WARRANTY EXCLUDES THE FOLLOWING:

1. Discoloration of the RANGER® pool cleaner. This is caused by reaction to ultraviolet rays and the chemicals used in the pool water. Discoloration does not affect the operating ability of the RANGER. Therefore, this Limited Warranty does not cover the replacement of discolored parts.
2. Damage to or malfunction of the unit resulting from excess chlorination or improper water chemistry balance.
3. Replacement of parts which fail or become defective as a result of improper installation, negligence, misuse, abuse or tampering by unauthorized repair personnel.
4. Age, pool water imbalance, and improper installation can cause vinyl pool liners to become brittle or unduly wrinkled. Corrosion of the supporting walls and/or irregularities in the pool base may also cause liner failure. The use of this product in such an environment is at the pool owner's risk. Therefore, the pool owner hereby releases the manufacturer from any and all claims for damage where these conditions exist.
5. The RANGER is designed for use in aboveground pools only. If unit is used in any other application, the pool owner hereby releases the manufacturer from any and all claims. This misuse will void all warranty on the unit.
6. In no event shall Zodiac Pool Care, Inc. be liable in contract or in tort, or under any other legal theory, for lost profits or revenues, loss of use or similar economic loss, or for indirect, special, incidental, consequential or similar damages, even if it has been advised of the possibility of such claim. Some states do not allow the exclusion or limitation of incidental or consequential damages, so the above limitation or exclusion may not apply to you.

IMPORTANT WARRANTY NOTICES FOR VINYL LINER POOL OWNERS

- Certain vinyl liner patterns are particularly susceptible to rapid surface wear or pattern removal caused by objects coming into contact with the vinyl surface, including pool brushes, pool toys, floats, fountains, chlorine dispensers, and automatic pool cleaners.
- Some vinyl liner patterns can be seriously scratched or abraded simply by rubbing the surface with a pool brush. Ink from the pattern can also rub off during the installation process or when it comes into contact with objects in the pool. **Zodiac is not responsible for, and the Limited Warranty does not cover, pattern removal, abrasion or marking on vinyl liners.**
- Vinyl liners are subject to deterioration or damage due to age, the effect of chemicals, corrosion or failure of the supporting walls; as well as improper installation, maintenance or cleaning of the supporting walls or base.
- Before installing the Ranger, examine the interior of your pool carefully. If your vinyl liner is brittle or has stones, wrinkles, roots or metal corrosion in contact with the underside of the liner, or has damage to the base material or supporting walls, do not install the Ranger before having a qualified professional perform the necessary repairs.

ZODIAC POOL CARE, INC. WILL NOT BE RESPONSIBLE FOR LINER DAMAGE CAUSED BY (1) A RANGER CLEANER WHICH IS IN DISREPAIR, (2) PATTERN REMOVAL FROM A VINYL LINER, OR (3) A RANGER CLEANER USED IN A POOL HAVING AN AGED OR DETERIORATED LINER.

WARRANTY PROCEDURES

No claim under this Limited Warranty will be recognized unless the registration card, included in your box, is completed and returned within fifteen (15) days of the purchase date. **Only the original purchaser may submit a claim under this Limited Warranty.** Purchaser's claims against Zodiac Pool Care, Inc., shall be limited to those claims which may be asserted under the Limited Warranty relating to any defect, malfunction or wear of the RANGER.

To obtain warranty replacements or repair, call (888) 786-7797 for authorization. When submitting a claim, always supply serial number, evidence of purchase date, retailer and a brief description of the problems/defects encountered. Zodiac Pool Care, Inc. reserves the right to repair or replace all defective or worn parts covered by this Limited Warranty and return same to purchaser, freight collect.

Zodiac Pool Care, Inc. assumes no responsibility for any warranties or representations made by other individuals or businesses beyond the express terms contained in this Limited Warranty.

This warranty gives you specific legal rights, and you may also have other rights which vary from state to state

For sale and use in the United States, Canada and Mexico only. This pool cleaner is not warranted or guaranteed outside of the United States, Canada or Mexico.

This pool cleaner is covered by one or more of the following Canadian and U.S. patents and Canadian registered design:

U.S. patent nos. 4642833, 4742593, 5450645, 5418995 and 5315728. Canadian patent nos. 1254105, 1256262, 2134220 and 2181896. Other Patents Pending.



ZODIAC

ABOVEGROUND AUTOMATIC POOL CLEANER INSTALLATION GUIDE

Pool Preparation 2
 Disc Installation..... 3
 Wheel Deflector Installation3
 Hose Assembly.....4
 Removing Air From Hose.....4
 Installation5
 Troubleshooting.....6
 Accessories7

HOW YOUR ZODIAC AUTOMATIC POOL CLEANER WORKS

- Your pool pump pulls water from the skimmer through a strainer basket, then pushes the water through the filter system and back into the pool through the return inlets.
- The Zodiac Automatic Pool Cleaner connects to the skimmer or dedicated vacuum line with the hose sections provided. Water flows through the Diaphragm of the cleaner at a rate of 14 to 19 gallons per minute.
- Diverting or re-directing the return inlets downward breaks up the circulation pattern of water within the pool. This allows random cleaning around the pool.
- Reading through the entire manual before installing your new Zodiac Automatic Pool Cleaner will help to insure it is installed properly and eliminate potential problems.

POOL COMPONENTS

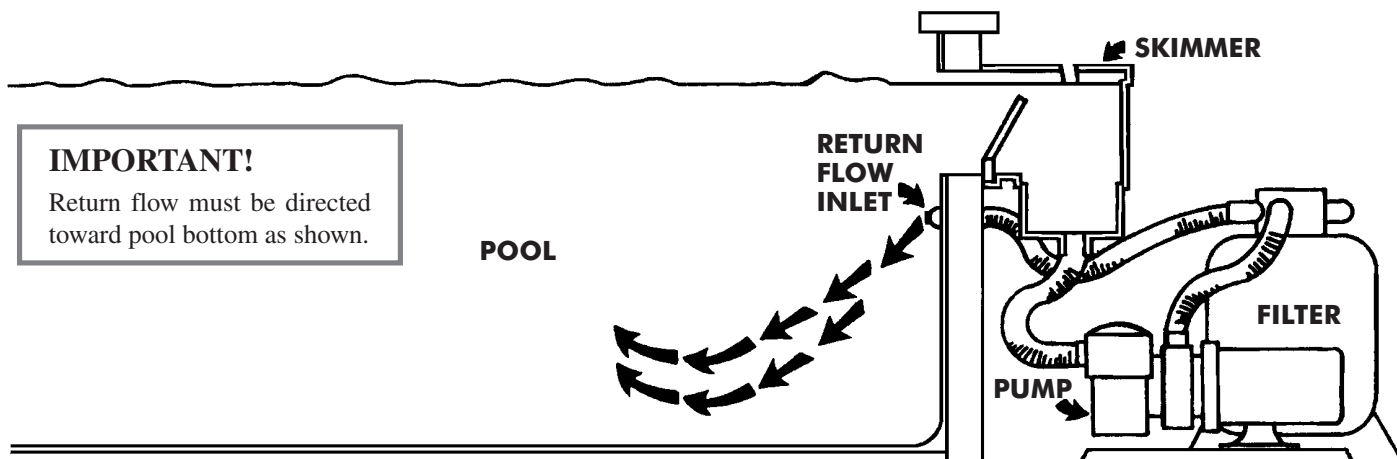

- Please become familiar with the components of your pool shown.
- All diagrams are provided for reference of terminology used throughout this manual. Your pool may vary.



Thank you for purchasing this Automatic Pool Cleaner from Zodiac. Prior to installing your pool cleaner, review the parts and warranty information and insure that all parts shown are included with your unit.

Although the appearance of your model Zodiac Pool Cleaner may differ slightly from some drawings shown in this installation guide, installation steps remain the same.

STEP 1 - POOL PREPARATION

- Before installing the Zodiac Automatic Pool Cleaner, examine the interior of your pool carefully. If your vinyl liner is brittle or has stones, wrinkles, roots or metal corrosion in contact with the underside of the liner, or has damage to the base material or supporting walls, do not install the pool cleaner before having a qualified professional perform the necessary repairs.
- Manually vacuum the pool. This eliminates unnecessary adjustment later.
- Clean the pool filter and empty the skimmer and pump strainer baskets. Filter pressure rises as debris is cleaned from the water, thus reducing flow.
- Divert the pool return inlets downward - (IMPORTANT!). Your Zodiac Automatic Pool Cleaner must move randomly throughout the pool. Water circulating at the surface will influence the hose and limit coverage.
 - To adjust the return inlet, loosen the lock ring and redirect the eyeball downward, then retighten the lock ring. If the eyeball is difficult to adjust, insert a screwdriver inside the eyeball and gently adjust downward.
 - If the return inlets cannot be pointed downward, then you **MUST** install Zodiac return line diverters. They are available through your Zodiac dealer.

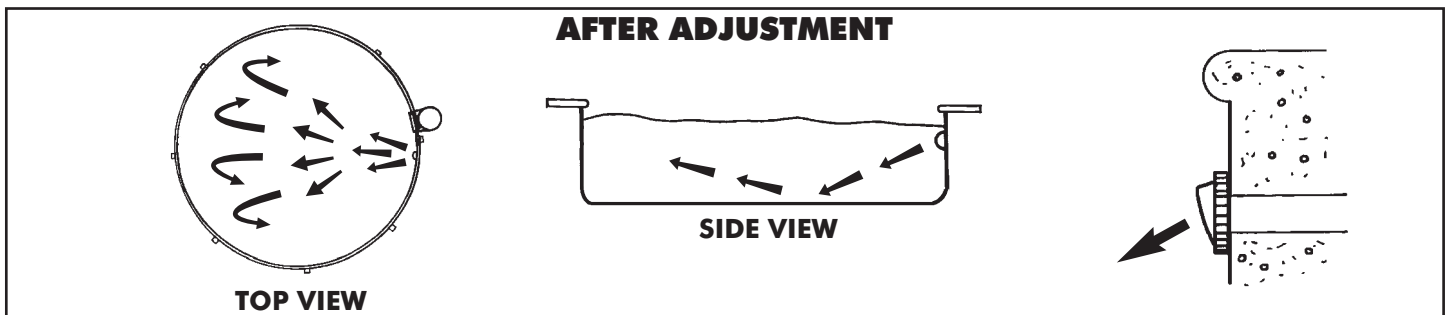
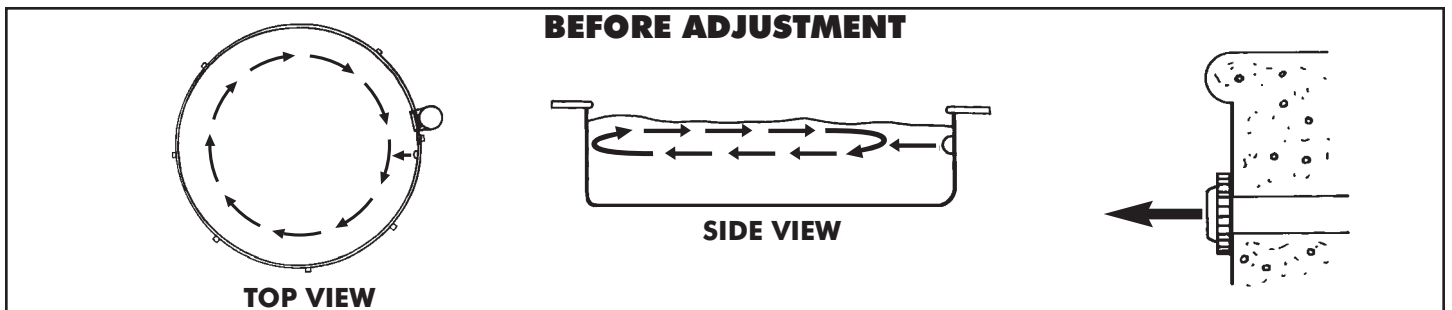

FOR POOLS WITH RETURN INLET DIRECTIONAL FITTINGS

Replace the directional eyeball with Zodiac retrofit eyeball return line diverter and reinstall eyeball retaining ring.

Part #W90153 for
1½" return lines
Part #W90155 for
2" return lines

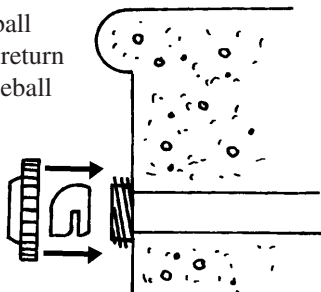

IF UNABLE TO ADJUST RETURN INLETS OR FOR POOLS WITHOUT RETURN INLET DIRECTIONAL FITTINGS

Use Zodiac universal return line diverter (Part #W24100). Pinch wires together and insert fully into return inlet.

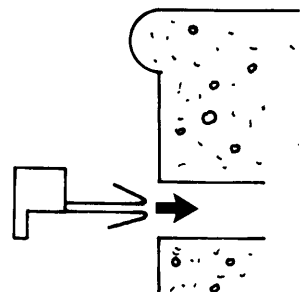

STEP 2 - DISC INSTALLATION

Slide the disc over the foot pad with the word "TOP" facing upward. Insure the disc fits properly in the grooves provided and rotates freely on the foot pad.

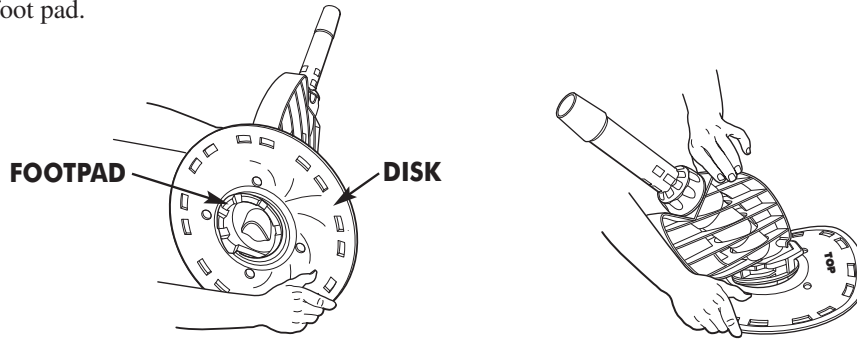

STEP 3 - WHEEL DEFLECTOR INSTALLATION

Zodiac Pool Cleaners require specific wheel deflector locations depending on the model. Follow the instructions below for your specific model. (Model number is stated on the manual cover.)

MODEL# W01099

Slide the wheel deflector onto the cuff of the first hose section that connects to the cleaner head.

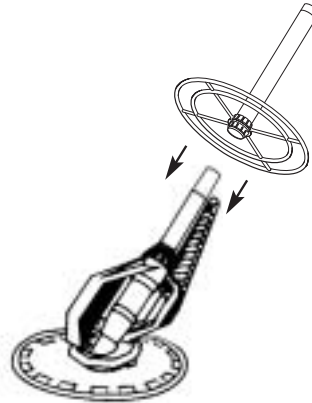

MODEL# W01698 and W83371

Slide wheel deflector onto the cassette swivel and over the wheel adapter.

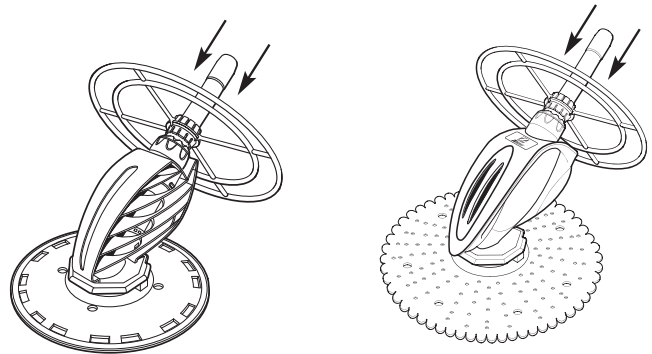

MODEL# W04598

Slide the wheel deflector over the outer extension pipe and secure between the two lowest pipe ridges.

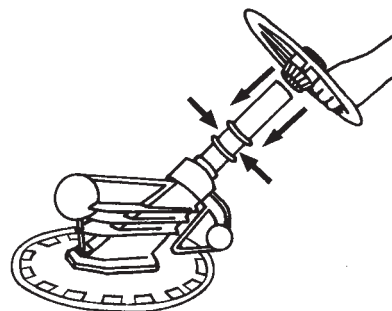

STEP 4 - HOSE ASSEMBLY

FOR CENTER INSTALLATIONS

Use enough hose sections to reach the farthest point in the pool, plus two (2) sections.

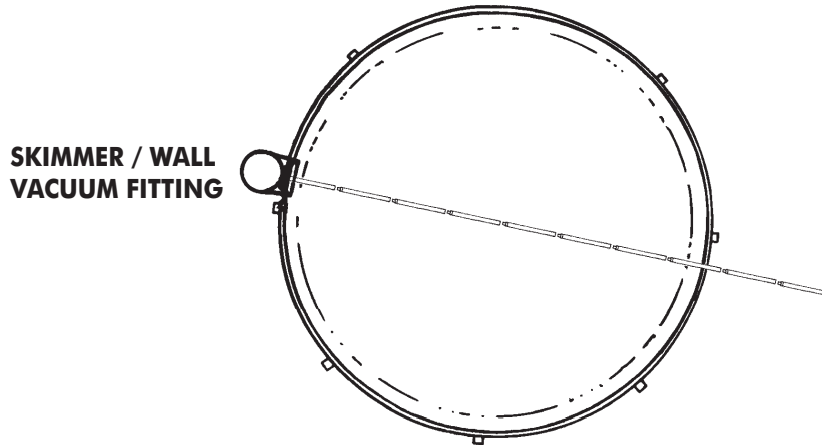

FOR CORNER OR END INSTALLATIONS

Use enough hose sections to reach the farthest point in the pool, plus one (1) section.

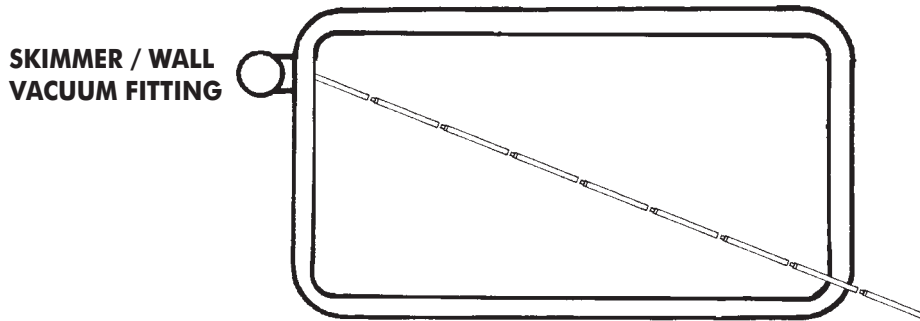

Note: You may not need to use all or you may need more hose sections, depending upon your pool size.

STEP 5 - REMOVING AIR FROM HOSE

- Submerge the pool cleaner head. When bubbles stop coming from the extension pipe, attach the cleaner head to the female end of the hose.
- Turn on the filtration system.
- Fill the hose with water by placing the end over a return inlet.

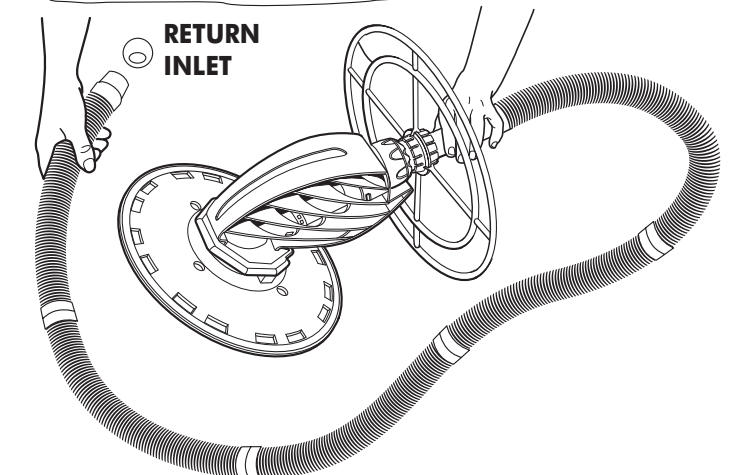
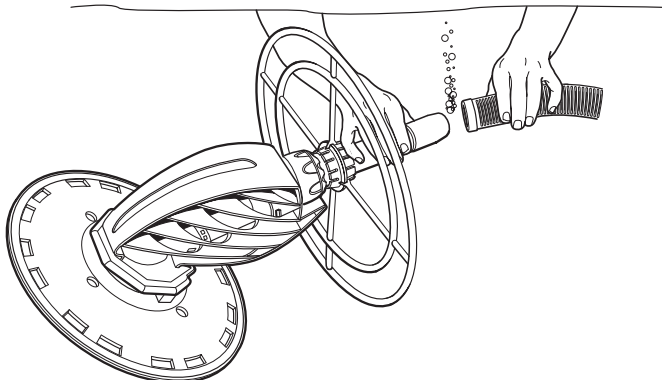

STEP 6 - INSTALLATION

FLOWKEEPER VALVE

The Flowkeeper Valve **MUST BE** used on all installations. The pool pump provides more gallon per minute flow than your pool cleaner requires. The Flowkeeper provides a way to regulate the flow with a bypass so the pool pump and the pool cleaner run properly. Skimming action is maintained through a bypass throat in the valve. As the filter collects debris, the valve automatically maintains the correct flow to the cleaner.

The Flowkeeper Valve comes preset at the setting required for your cleaner. There are a total of three setting options. The lower the setting number, the lower the flow to the cleaner head. Lower flow rates result in slower cleaner operation, and higher flow rates result in faster cleaner operation. If the cleaner is moving extremely fast or climbing the pool walls that is an indication that the flow is too high and the Flowkeeper setting must be reduced. To adjust the flow, pull the adjustment handle to raise or lower the setting. The red tab on the valve can be depressed to keep the bypass open to allow for surface skimming. In most cases, keeping the bypass open will cause the cleaner to stop.

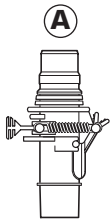
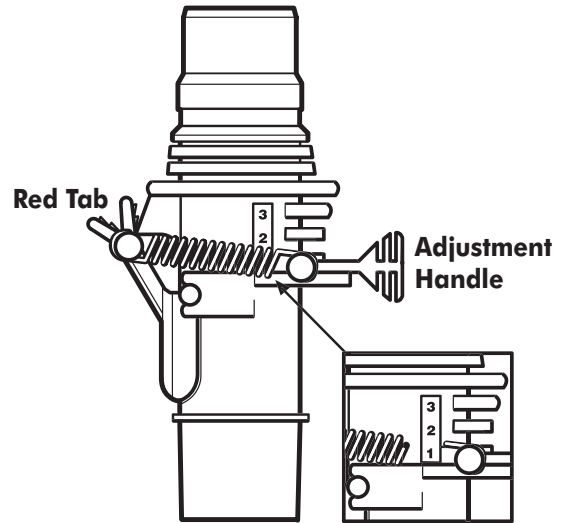

(1) Flowkeeper Valve

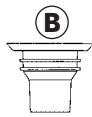

(1) Valve Cuff

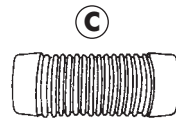

(1) 4 1/2" Connector



(1) 45° Elbow

- Using the parts shown, choose a fitting combination best suited for your pool from figures A or B and install. You may have parts left over.
- Once installed, turn on the pump and allow the cleaner to begin cleaning the pool. Your installation is now complete.

FIGURE A Skimmer Installation

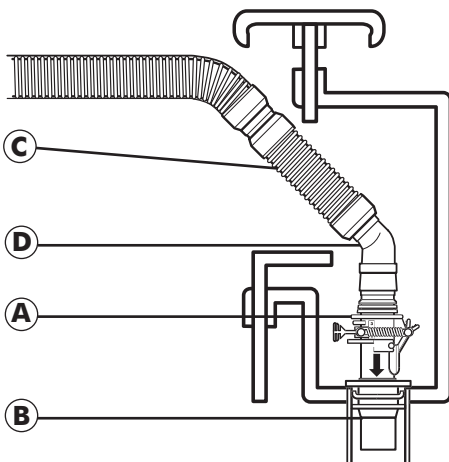

Arrow on Flowkeeper must be pointed downward, toward skimmer.

FIGURE B Vacuum Line Installation

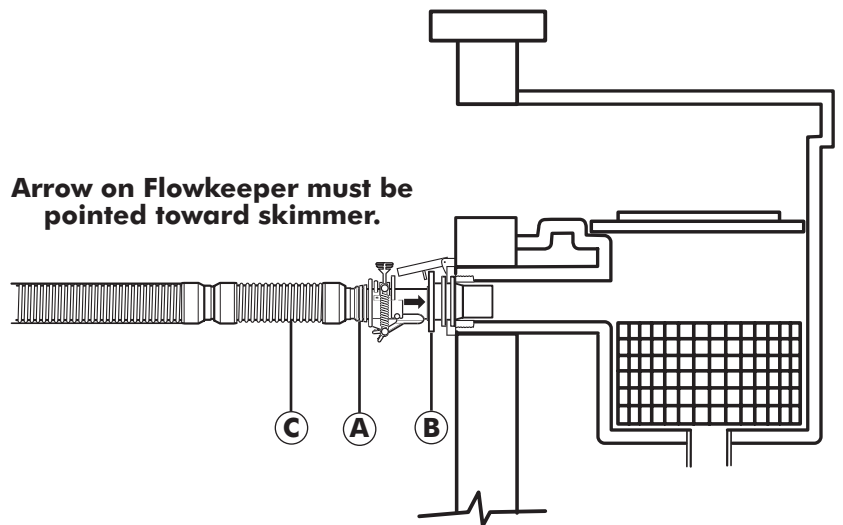

Important: To help prevent suction entrapment accidents, wall vacuum fittings should have a safety vac lock installed. Contact your builder or retail pool professional for details.

TROUBLESHOOTING

PROBLEM

SOLUTION



Cleaner stops & starts	<ul style="list-style-type: none"> • Ensure the pump is on high speed, if pump has two speeds. • Check Diaphragm for blockage or damage. • Check hoses for leaks. • Clean baskets and filter.
Cleaner is patterning	<ul style="list-style-type: none"> • Add return diverters or divert return inlets downward. • Lay hose in a straight line in the sun to relax memory. • Confirm proper hose length - add 1 to 2 hose sections. • Purchase Hose Deflectors from your Zodiac Dealer.
Cleaner isn't covering opposite end of pool	<ul style="list-style-type: none"> • Use return flow to move cleaner to opposite end. • Add return diverters or divert return inlets downward.
Cleaner stuck at steps	<ul style="list-style-type: none"> • Utilize return flow to move cleaner. • Confirm proper hose length. • Reduce the setting on the Flowkeeper Valve. • Install a large 16" wheel deflector.*
Cleaner stuck on ladder	<ul style="list-style-type: none"> • Reduce the setting on the Flowkeeper Valve. • Remove ladder if possible. • Install a large 16" wheel deflector.*
Cleaner flips over	<ul style="list-style-type: none"> • Contact Tech Services for local warranty station.
Cleaner moves extremely fast or climbs walls	<ul style="list-style-type: none"> • Reduce the setting on the Flowkeeper Valve.
Cleaner moves slowly	<ul style="list-style-type: none"> • Increase the setting on the Flowkeeper Valve. • Ensure the pump is on high speed, if pump has two speeds. • Check Diaphragm for blockage or damage. • Check hoses for leaks. • Clean baskets and filter.
Cleaner doesn't move	<ul style="list-style-type: none"> • Clean baskets & filter. • Check Diaphragm for blockage or damage. • Check hose sections for leaks by lifting each section above water. • If your pool has multiple skimmers, close the skimmer the cleaner is not attached to.
Solar blanket installation	<ul style="list-style-type: none"> • Coverage will be limited due to blanket.

* If your cleaner did not include a large 16" wheel deflector, it can be purchased from your dealer as an accessory.

NOTE: In cold water of 60° or less, water flow through the cleaner must be increased to compensate for the reduced flexibility of the hose and diaphragm. To increase flow, increase the setting on the Flowkeeper Valve.

**IF ADDITIONAL ASSISTANCE IS REQUIRED,
PLEASE CALL TECH SERVICES AT 1-888-786-7797**

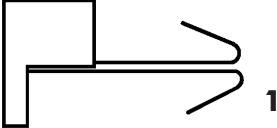
ZODIAC ACCESSORIES

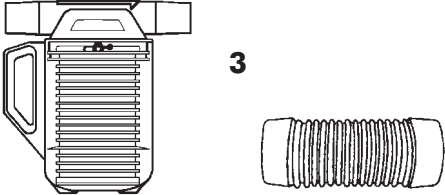
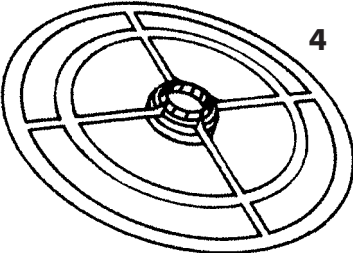
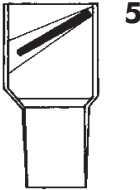
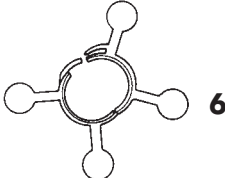
PART ILLUSTRATION	PART NO.	DESCRIPTION
	<p>1. W24100</p>	<p>Return Line Diverter Use when no other return inlet directional fittings exist.</p>
	<p>2A. W90153 (for 1 1/2" return inlet)</p> <p>2B. W90155 (for 2" return inlet)</p>	<p>Retrofit Eyeball Return Line Diverter Use to replace standard directional inlet eyeballs</p>
	<p>3. W26705</p>	<p>The Leaf Catcher with 4 1/2" Hose Connector Use when heavy debris or leaf situations exist.</p>
	<p>4. W46155</p>	<p>Large 16" Wheel Deflector Prevents sticking at steps or other obstacles.</p>
	<p>5. W44800</p>	<p>Pool Pulse Flow meter that measures the volume of water running through the cleaner for troubleshooting and setting flow.</p>
	<p>6. W24209</p>	<p>Hose Deflector Use to correct patterning or coverage issues.</p>



ZODIAC POOL CARE, INC.

2028 N.W. 25th Avenue
Pompano Beach, FL 33069
1-888-786-7797
www.zodiacpoolcare.com

RANGER® CARE AND MAINTENANCE

To maintain quality, performance and increase the lifespan of your Ranger, please do the following:

1. Thoroughly clean the skimmer basket, pump basket and pool filter on a regular basis. **Always disconnect the hose from the skimmer before backwashing.**
2. **REMOVE THE CLEANER BEFORE SUPER CHLORINATING OR ADDING POOL CHEMICALS.** Reinstall the Ranger when the imbalance is corrected or after a minimum of 4 hours from super chlorination. Chemical damage is not covered under warranty.
3. **NEVER COIL THE HOSE** when the cleaner is removed from the pool. A coiled hose can be straightened with hot water or by laying it on a warm pool deck for several hours.

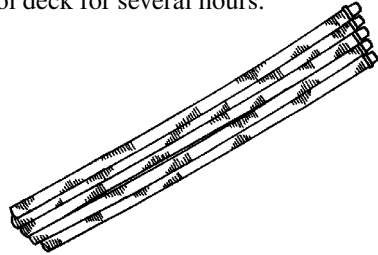

CORRECT

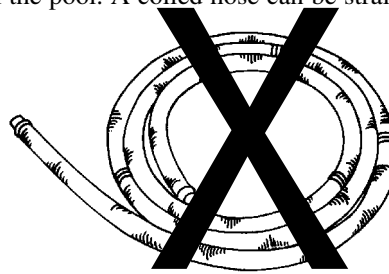

INCORRECT

4. Remove disc and store it flat during the off-season. Store the cleaner head in a warm and dry place.

Quick Access Cassette System

Unlike other competitive automatic pool cleaners, the RANGER has the Quick Access Cassette System. This unique feature allows almost instantaneous access to the one moving part – the diaphragm.

Large foreign objects, such as children's toys, tree branches and rocks, should be removed manually from your pool prior to operating an automatic pool cleaner. In the event a foreign object does not get manually removed and a blockage occurs, the Quick Access Cassette System allows you the opportunity to remove the blockage or check the diaphragm for damage in minutes at poolside. (Before beginning, be sure to remove the wheel deflector and adapter from the cleaner head.)

DIAPHRAGM REMOVAL

Holding the frame assembly in one hand, unscrew the cassette (Step 1) and remove (Step 2). Holding the cassette at each end, unscrew the cassette pipe from the diaphragm chamber two full turns (Step 3). Grasp the lip of the diaphragm and pull the diaphragm out (Step 4). The inner pipe will be attached and will make a loud noise. Pull the diaphragm off of the inner pipe, leaving the retaining ring on the diaphragm (Step 5), and inspect for blockage or cuts. Remove blockage and rinse. Do not use sharp objects as damage to diaphragm may occur. If replacement parts are needed, contact technical service at 1-888-786-7797 for an authorized warranty station.

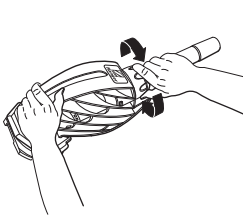

Step 1

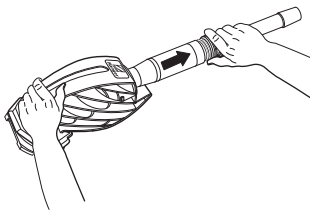

Step 2

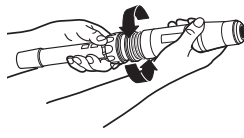

Step 3

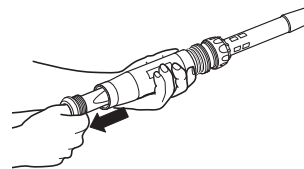

Step 4

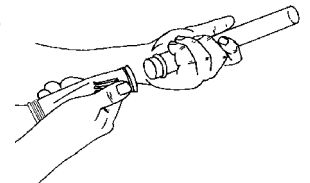

Step 5

DIAPHRAGM ASSEMBLY

Prior to reinstalling the diaphragm, rinse the diaphragm and inner extension pipe thoroughly to remove any grit or algae. Attach the diaphragm to the inner extension pipe using the retaining ring (Step 6). Slide the inner extension pipe into the diaphragm chamber. Pressing on the underside of the diaphragm's ridges, push the diaphragm into the chamber (Step 7). Holding the cassette at each end, tighten the cassette pipe until snug. Do not overtighten. (Step 8). Insert the cassette assembly into the frame assembly and tighten (Step 9).

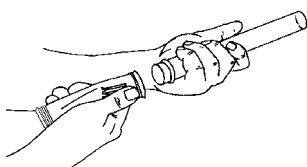

Step 6

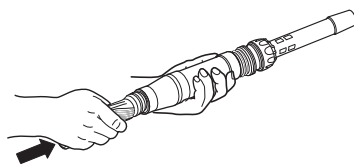

Step 7

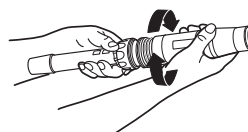

Step 8

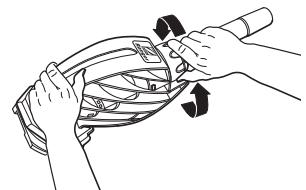

Step 9

RANGER® PARTS DIAGRAM

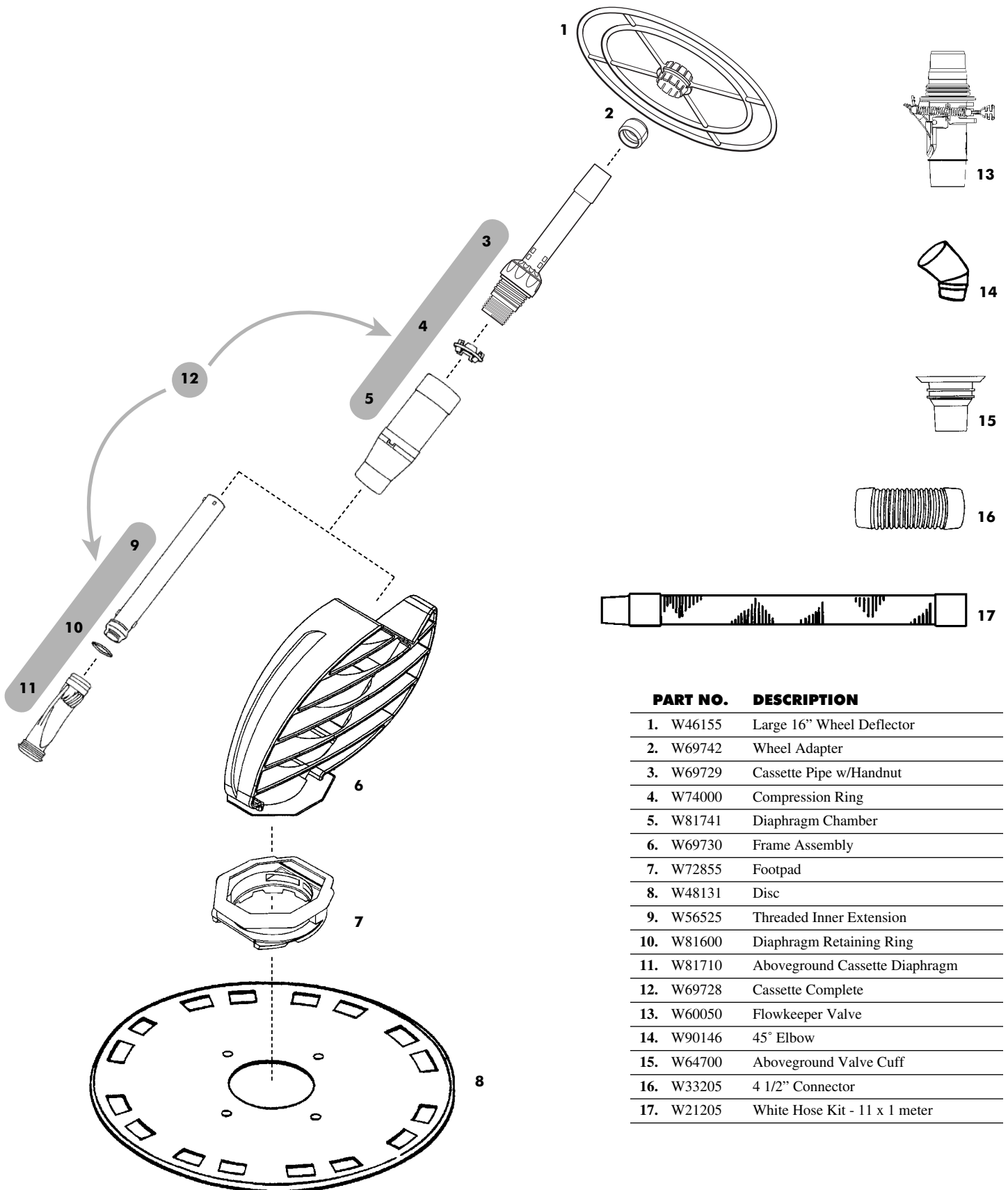

PART NO.	DESCRIPTION
1.	W46155 Large 16" Wheel Deflector
2.	W69742 Wheel Adapter
3.	W69729 Cassette Pipe w/Handnut
4.	W74000 Compression Ring
5.	W81741 Diaphragm Chamber
6.	W69730 Frame Assembly
7.	W72855 Footpad
8.	W48131 Disc
9.	W56525 Threaded Inner Extension
10.	W81600 Diaphragm Retaining Ring
11.	W81710 Aboveground Cassette Diaphragm
12.	W69728 Cassette Complete
13.	W60050 Flowkeeper Valve
14.	W90146 45° Elbow
15.	W64700 Aboveground Valve Cuff
16.	W33205 4 1/2" Connector
17.	W21205 White Hose Kit - 11 x 1 meter

ZODIAC POOL CARE, INC.

2028 N.W. 25th Avenue
 Pompano Beach, FL 33069
 1-888-786-7797
 www.zodiacpoolcare.com