

sunpak

TM

MODEL S25 & S34 GAS-FIRED INFRARED HEATER For Indoor or Outdoor Operation

Manufactured by

INFRARED DYNAMICS, INC.

3830 Prospect Ave. • Yorba Linda, CA U.S.A.
Phone: (714) 572-4050

PROP. 65 WARNING!!!

If not installed, operated and maintained in accordance with manufacturer's instructions, this product could expose you to substances in the fuel or from combustion which can cause death or serious illness and which are known to the State of California to cause cancer, birth defects or reproductive harm.

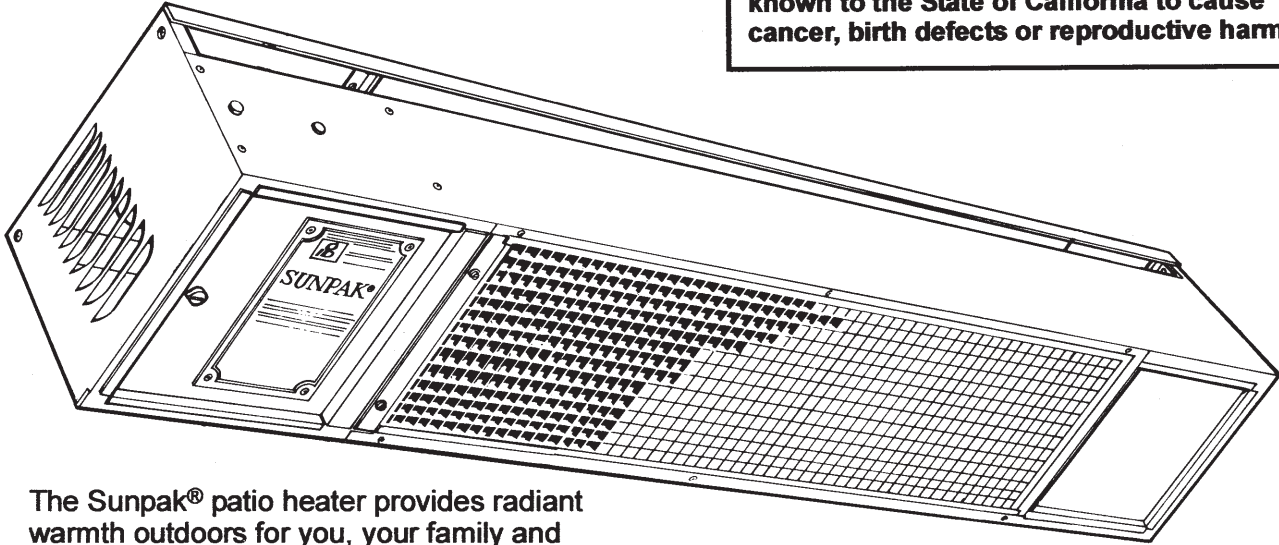

The Sunpak® patio heater provides radiant warmth outdoors for you, your family and friends.

Sunpak® is C.S.A. Intl. Design-certified as an unvented infrared heater for outdoor or indoor installation. All units are equipped with spark ignition and 100% shutoff for safety, economy and convenience.

Sunpak's® aluminized steel enclosure and aluminum face grille provide's resistance to wind and rain. A slim body and 0-30 degree angle mounting option on most models, gives Sunpak® the versatility to fit easily into a wide variety of patio situations.

WARNING: Improper installation, adjustment, alteration, service or maintenance can cause property damage, injury or death. Read the installation, operating and maintenance instructions thoroughly before installing or servicing this equipment.

Retain these instructions for future reference.
Installation of Sunpak® heaters should only be performed by those persons knowledgeable about gas appliances.

HEATER FEATURES:

- Slim Profile (8"H x 8"W x 47"1/2L)
- Decorative Safety Grille
- Reduced Clearance Requirements
- Angle Mounting—Zero to 30 Degrees
- Rain Protected
- Wind Resistant
- 25,000 or 34,000 BTU/HR. Input
- Natural or Propane Gas
- Direct Spark Ignition
- 100% Safety Shutoff



Installation, Operation and Maintenance Instructions for Sunpak® Infrared Space Heaters...

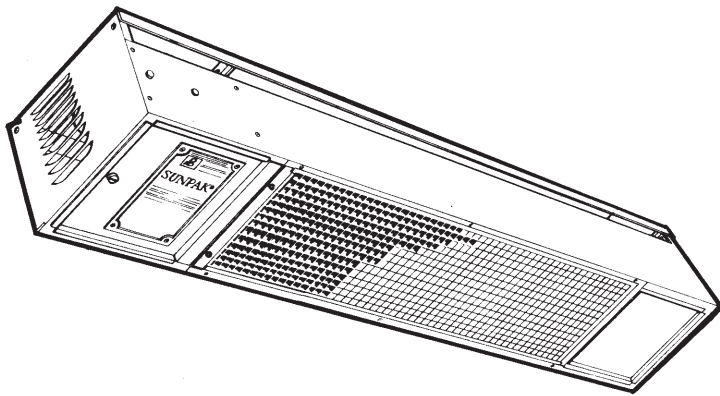

INSTALLATION

Prior to installing your Sunpak infrared space heater, the following should be reviewed. Compliance with the following should yield satisfactory heater operation and minimize installation costs.

1. Heaters to be installed in Aircraft hangars must be installed in accordance with American National Standards for Aircraft Hangars, ANSI/NFPA No. 409.
2. Heaters to be installed in Public Garages must be installed in accordance with NFPA No. 88A Standards for Parking Structures.
Heaters must be installed so that minimum clearances marked on the heater will be maintained from vehicles parked below the heater.
3. The installation must conform with ANSI standard No. Z223.1 entitled "National Fuel Gas Code" and any applicable local codes. In Canada, the installation must conform with local building codes or, in the absence of local codes, with the National Standards of Canada CAN/CGA-B 149.1&2-M86.
4. Each heater must be electrically grounded in accordance with the National Electrical Code, ANSI/NFPA 70 when an external electrical source is utilized. In Canada, the CSA Canadian Electrical Code, C22.1, Part I applies.
5. The gas inlet supply and normal operating manifold pressure for each heater are as follows. For gas supply line pressures in excess of ½ psig, consult with your representative or the factory.

Gas Inlet Pressure	Nat. Gas	LP Gas
Maximum Pressure	½ psig	½ psig*
Minimum Pressure	6" W.C.	11" W.C.
Manifold Pressure	5" W.C.	10" W.C.

*Tank pressure before regulator.

6. Do not locate either the gas or electrical supply line directly over the flue outlet of the heater. Electrical supply line shortage and/or control overheating may occur.
7. The heater must be installed in a location such that it is readily accessible for servicing and have no restriction of air flow to the air inlet of the heater's casing.

MOUNTING

Each heater must be installed such that the following "Minimum Clearance to Combustibles" are maintained.

Combustible materials are considered to be wood, compressed paper, plant fibers, plastic, Plexiglas or other materials capable of being ignited and burned. Such materials shall be considered combustible even though flame-proofed, fire-retardant treated or plastered. Additional clearance may be required for glass, painted surfaces and other materials which may be damaged by radiant or convection heat.

OPTIONAL MOUNTING KIT (#12006): Optional Mounting Kit is available from your heater supplier. Whether the mounting kit is used or not, minimum clearance from combustibles must be observed as follows:

WARNING: The clearances shown below are also applicable to vehicles parked below heaters.

Model	Input BTUH	Side In	Rear In	Ceiling In	Below In	Mtg. Angle
S25	25,000	24"	12"	9"	48"	HORIZ.
S34	34,000	24"	17"	13"	48"	HORIZ.
*S25	25,000	24"	8"	14"	48"	30 DEG. MAX.
S34	34,000	24"	8"	18"	48"	30 DEG. MAX.

Above clearances apply to models on either natural or LP gas.

*Model S25 for LP gas for use in horizontal position only.

ELECTRICAL

1. Provide only a 24VAC volt NEC Class 2 transformer to the heater. A step down transformer approved as having at least a 20VA rating must be utilized for each connected heater.
2. Control wire used to electrically connect one or more heaters together must have both adequate capacity and insulation temperature ratings for the total connected load. Use at least 18 ga. wire up to 50 Ft. from heater to transformer or wall switch. Use 16 ga. Over 50 Ft. distance.
3. If any of the original wire supplied with the appliance must be replaced, it must be replaced with wiring material having a temperature rating of at least 105 degrees Centigrade.



MODEL S25 & S34 GAS-FIRED INFRARED HEATER For Indoor or Outdoor Operation

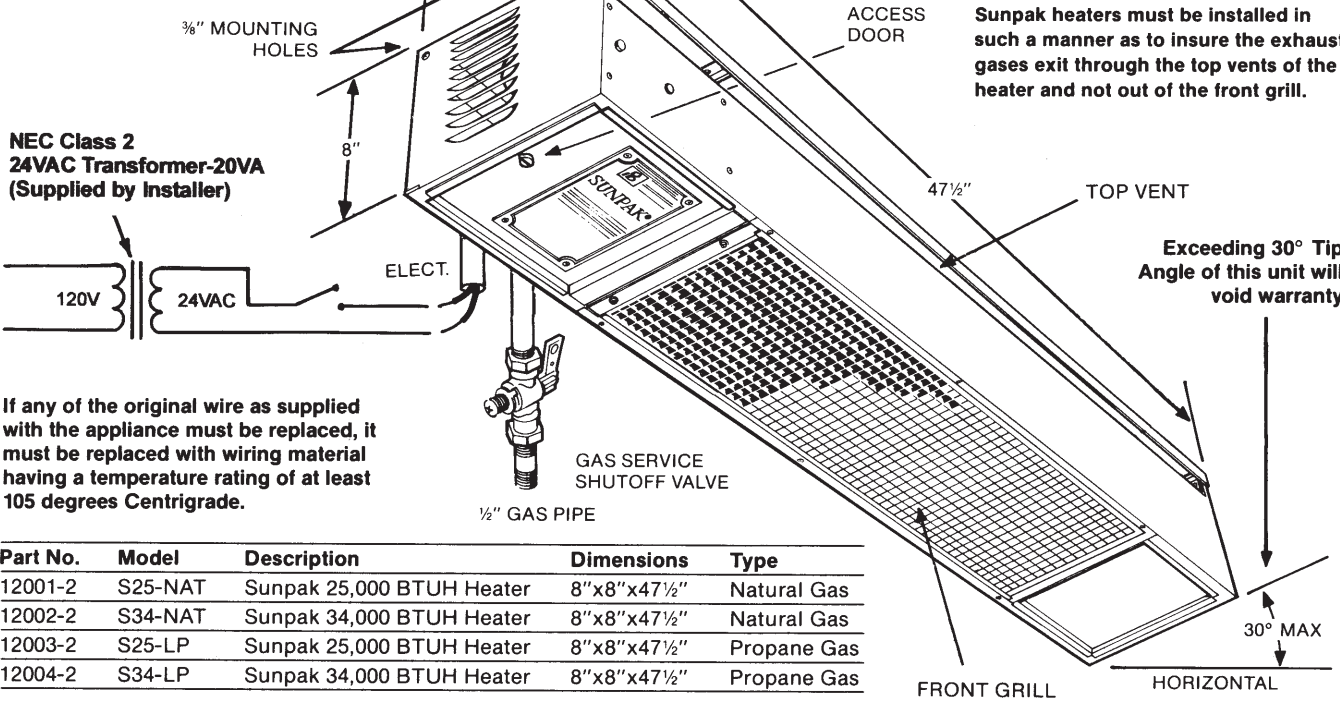

Part No.	Model	Description	Dimensions	Type
12001-2	S25-NAT	Sunpak 25,000 BTUH Heater	8"x8"x47 1/2"	Natural Gas
12002-2	S34-NAT	Sunpak 34,000 BTUH Heater	8"x8"x47 1/2"	Natural Gas
12003-2	S25-LP	Sunpak 25,000 BTUH Heater	8"x8"x47 1/2"	Propane Gas
12004-2	S34-LP	Sunpak 34,000 BTUH Heater	8"x8"x47 1/2"	Propane Gas

If any of the original wire as supplied with the appliance must be replaced, it must be replaced with wiring material having a temperature rating of at least 105 degrees Centigrade.

CEILING MINIMUM CLEARANCE FROM COMBUSTIBLES MUST BE MAINTAINED (see chart on opposite page)

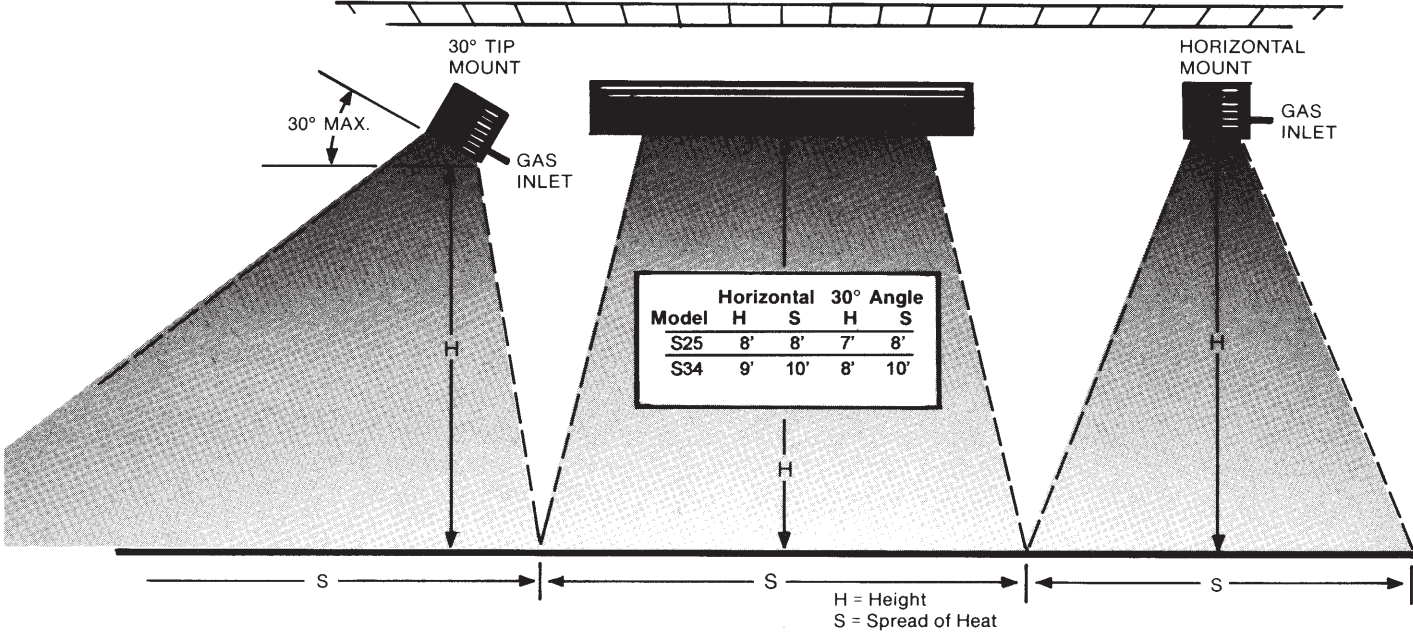

SUNPAK will raise the comfort level 5-10° Fahrenheit outdoors. The above coverage table was based on still breeze conditions. Under windy conditions, more heat will be required. For example, a 5 mph breeze typically will require twice as many heaters to achieve the same heat comfort level. It is recommended that a windswept patio be designed with wind breaks in order to stabilize the patio environment.

ANGLE MOUNTING: Most models of the SUNPAK heater may be angle-mounted to a maximum of 30° to accommodate mounting the heaters around the edges of the patio. Note that top clearance to combustibles increases when heater is tipped from the horizontal.

NOTE: Where applied, the *Uniform Mechanical Code* requires that all portions of overhead radiant heaters are located at least 8 feet above the floor.

Sunpak® Infrared Heater Location

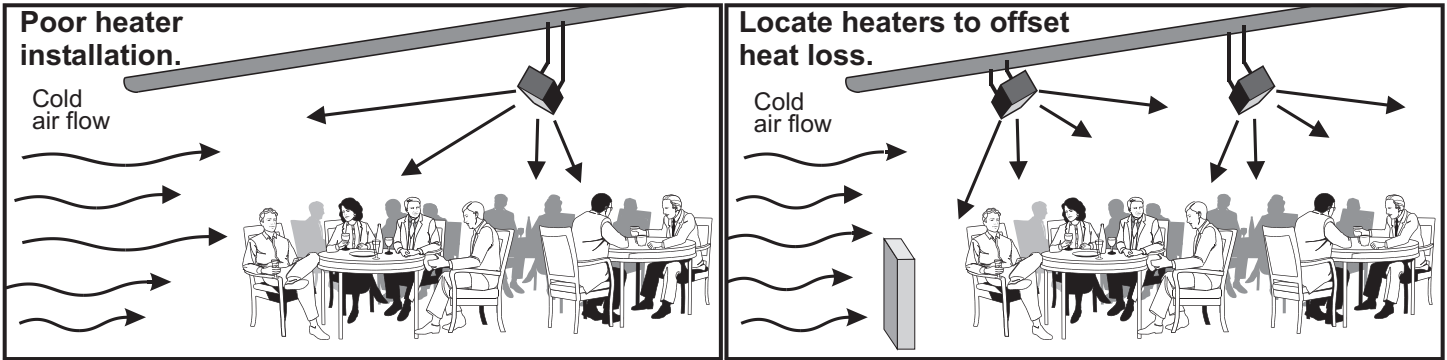

Suggested Installation Configurations

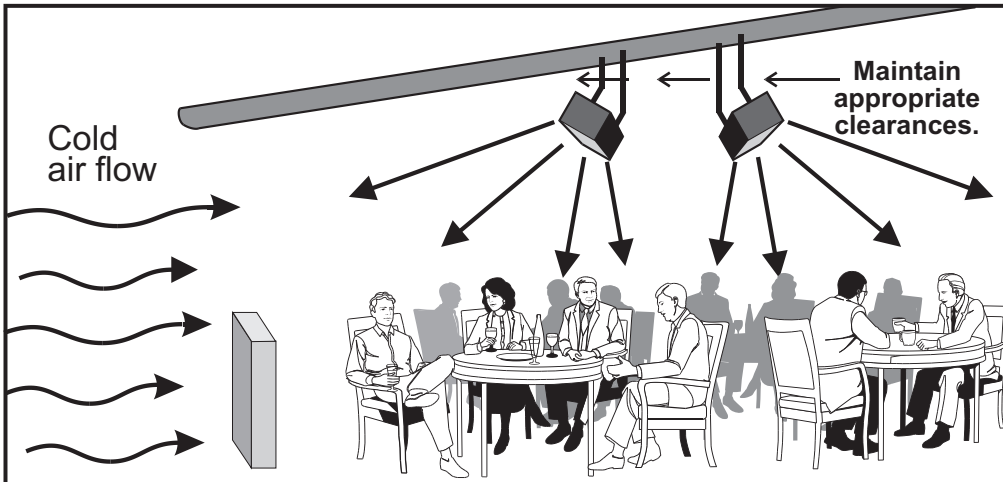

CLUSTER ARRANGEMENT
Heaters are placed in groups, facing away from each other using a maximum 30 degree angle.

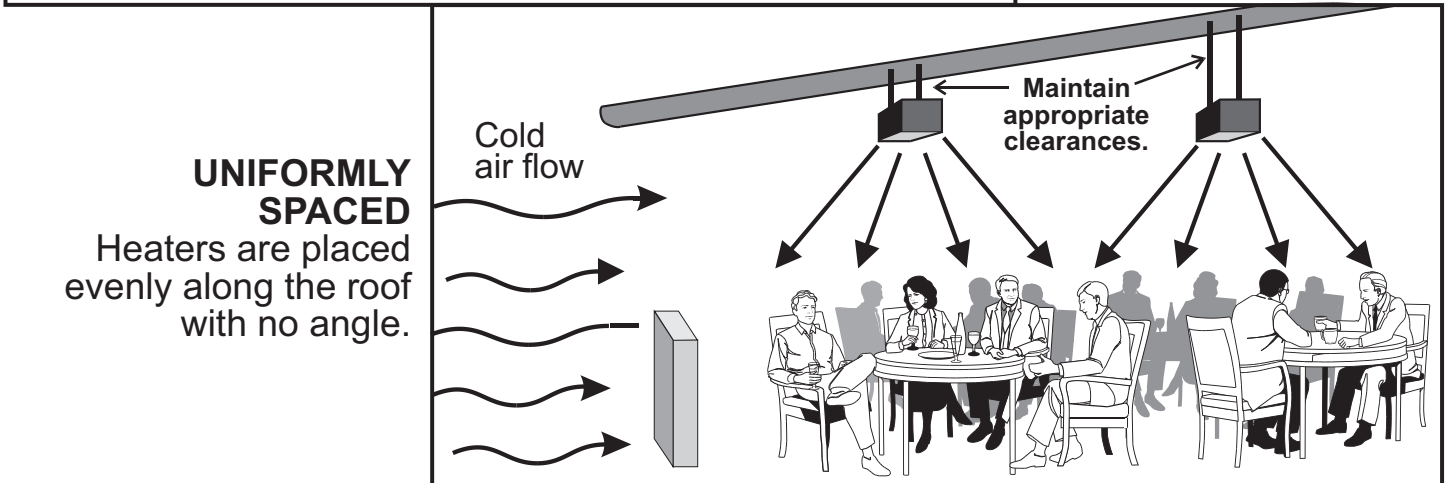

UNIFORMLY SPACED
Heaters are placed evenly along the roof with no angle.

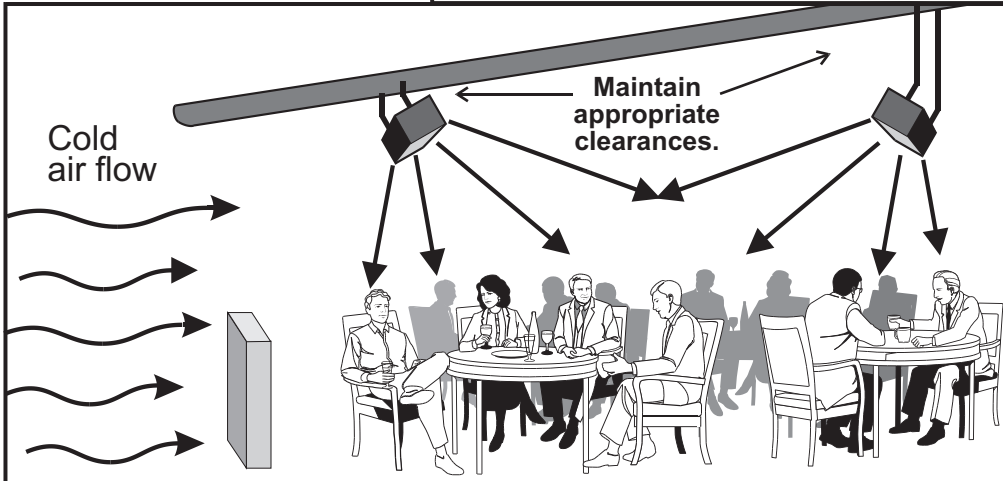

OPPOSITE ARRANGEMENT
Heaters are installed using the 30 degree maximum angle to face toward each other.

Sunpak® Infrared Space Heaters

INFRARED HEAT

Sunpak® heaters are effective in heating outdoor areas because they utilize infrared or radiant heat instead of hot air. Infrared heat is the same type of warmth we get from the sun, or from a fire. Infrared heats warms people and objects directly without heating the intervening air. Unlike the sun, Sunpak® heaters do not produce the harmful ultraviolet (UV) rays that cause sunburn.

Infrared heat travels by line-of-sight. Be aware that doors, windows, or panels may obstruct the infrared heat from reaching a desired location on the patio. Overlapping patterns of infrared heat from multiple units may be used effectively to create uniformly heated areas.

TEMPERATURE CONTROL

Though a thermostat can be incorporated into the electrical circuit, it may not be the best means of temperature control. Because the infrared heat warms people and objects, when used outdoors the heater may not increase the air temperature and thus the thermostat is never satisfied.

Where multiple heaters are used it is suggested that they be put on individual switches to provide flexibility in heating. Typically all the heaters would be turned on to heat a cold patio, and then heaters would be turned off selectively as people settle in. A timer or master switch may be convenient to ensure the heaters are not turned on when the patio is not in use.

ENCLOSED PATIOS

The patio structures must be large enough to meet Sunpak's clearance, combustion air and ventilation requirements. For very small or enclosed patios, Sunpak® heaters may not be appropriate.

PATIO DESIGN CONSIDERATIONS

Heater placement is critical for effective and efficient patio heating. If heaters are placed too close together or mounted too low, people become uncomfortable. If heaters are placed too far apart on a breezy, wind-swept patio, the patio may never get warm.

Sunpak® heaters work best if they are placed in areas of the greatest heat loss, such as the open side of a semi-protected patio area. The Sunpak® heater may be mounted at up to a 30 degree angle to allow the radiant warmth to project inward to the center of the patio. Note that the clearances needed from combustibles increase when heaters are angled (see table for details).

Sunpak® heaters may be laid out in a number of configurations depending on the structural constraints of the patio and heating requirements. One approach is to face them straight down over the tables and seating areas. Another approach is to locate them to the side and angle them inward. A third approach is to cluster the heaters in the center of the patio and angle them outward. It all depends on the needs of the particular patio.

Breezy conditions can be a problem when heating any patio. Windbreaks can be extremely effective in increasing comfort and reducing heating costs.

Sunpak® heaters should always be operated in a uniform pressurized environment. If only part of the heater is located in a wind protected zone, then the whole heater should be re-located in the wind protected zone. If part of the heater is exposed to the full force of the wind, then the whole heater should be exposed to the full force of the wind.

The heating requirements for any particular patio vary widely depending on the local climatic conditions. It is recommended that you work with a local Sunpak® installer who is familiar with heating requirements for your area.

HEATER CLEARANCES

Sunpak® heaters must be located with adequate space around each unit. When placed near wood or other flammable materials, appropriate clearances from combustible materials **must be maintained**. Even if the materials surrounding the heater are non-combustible, adequate space around the heater is required to provide sufficient combustion air, ventilation of exhaust gases, and the general safe operation of the heater. Sunpak® heaters should NEVER be located in a ceiling recess or inside a soffit.

FIRE SPRINKLER CONSIDERATIONS

It is extremely important that the Fire Sprinkler Systems be properly integrated with the layout of the heaters. Fire sprinkler heads must be located an appropriate distance from the heater, or a sprinkler head with a high enough temperature rating, that normal operation of the heater will not activate, **must be used**. Specific guidelines can be found in NFPA 13 regarding design and specifications for Fire Sprinkler Systems near heaters. Fire Sprinkler Systems that use Propylene Glycol or antifreeze solutions or other potentially flammable substances should not be used in conjunction with our heaters.

LIGHTING Instructions

TO START HEATER:

1. Turn manual gas valve to "ON" position.
2. Turn electrical supply "ON."

TO SHUT DOWN:

1. Turn manual gas valve to "OFF" position.
2. Turn electrical supply "OFF."

CAUTION: If burner fails to ignite, shut down electrical power and wait five (5) minutes before turning power "ON."

SERVICING INSTRUCTIONS

Turn off gas and electrical before attempting any service to this appliance. Heater may be serviced by opening door to control compartment. Rotate round slotted disk on control door 90 degrees to open. Top of heater may be removed for servicing by removing six(6) screws holding top in place. The top should be removed if the gas controls, burner or burner orifice is to be replaced.

1. REMOVAL OF BURNER

- a. Remove grille by removing two (2) screws at one end of grille near control door. Pull downward at the end and grille will be loose. The far end of the grille is supported by two (2) pins that enter two (2) holes in the reflector's far end.
- b. Remove top of heater by removing six (6) screws holding top in place.
- c. The burner can be removed without removing the pilot-electrode assembly. However, extreme care should be taken to prevent the burner from contacting the fragile electrode when removing or reinstalling the burner. To remove the pilot-electrode assembly, pull loose the wire connected to the electrode. Detach the pilot tubing. Remove the two screws holding the pilot-electrode in place.
- d. Remove $\frac{3}{8}$ " hex locknut located inside burner orifice bracket holding piping assembly to burner. A $\frac{7}{8}$ " 12-point wrench will be handy to loosen the $\frac{3}{8}$ " locknut from the top of the heater.
- e. Remove two (2) screws holding the end of the burner. Carefully slide burner down and out. When reinstalling, be sure both ends of the burner are beneath the reflector end flanges.
- f. To reinstall burner, reverse procedure.

2. REMOVAL OF RAM-3 DIRECT SPARK IGNITION CONTROL

- a. Disconnect two 24VAC volt power leads.
- b. Disconnect two valve leads.
- c. Disconnect ignitor lead from control.
- d. Disconnect green ground lead from casing.
- e. Remove two (2) 8-32 x $1\frac{1}{4}$ screws and nuts holding control in place. Screw heads are located on exterior front side of heater above control compartment door.
- f. If insufficient removal clearance, loosen control assembly and move out of way.

TROUBLE SHOOTING

1. If no spark from electrode; or if gas valve doesn't work then:
 - a. Check power supply. Should have 24 volts between power wires. Use volt meter between inlet 24 volts wire and ground terminal at electrode plate to measure 24 volts.
 - b. Check continuity. Use ohmmeter. For example, check resistance between valve wire and ground. Should show almost no resistance (0 ohms) through valve. If high resistance, check wire connectors.
 - c. Check spark gap. Should be $\frac{7}{64}$ " (.109") between electrode tip, and pilot hood. If gap is too large, spark will occur at wrong location. If gap is too small, spark may not be hot enough to light pilot burner.
 - d. Be sure connectors are fully inserted into ignition control (See Wiring Diagram on rating plate).
2. If insufficient gas flow then:
 - a. Gas manual valve not full "ON." Turn valve handle to full "ON" position.
 - b. Burner orifice plugged. Remove heater top, remove burner orifice (use $\frac{1}{2}$ " hex wrench) and thoroughly clean. Spiders often crawl into orifice hole and make a web, blocking the orifice.

STAINLESS STEEL HEATER

Stainless steel does not "rust", however air pollution can leave brown deposits on the heater. We recommend washing the outer stainless steel casing only with a mild detergent solution and wiping it dry with a soft cloth to bring back the original shine. The stainless steel may be expected to permanently darken around the flue outlet at the top of the heater over time with extended use.

sunpak™

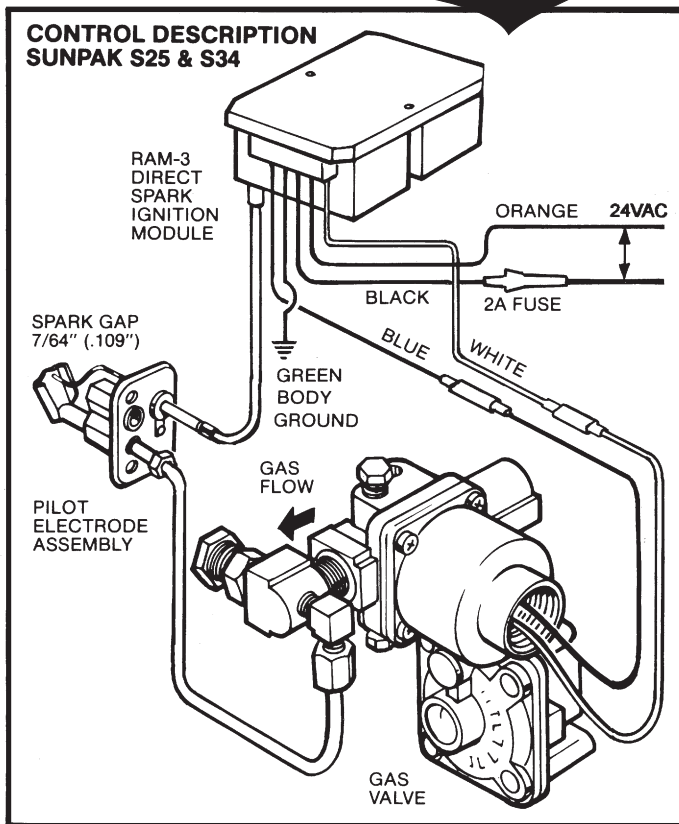

GAS PIPING

1. A minimum pipe size of $\frac{1}{2}$ " is required for inlet piping. A $\frac{1}{2}$ " lever handled shut-off gas cock should be installed within 6 feet of the appliance for servicing the unit.
2. Check with local and state plumbing and heating codes regarding sizing of the gas lines.
3. All gas pipe connections to the heater(s) must be sealed with a gas pipe compound resistant to liquefied petroleum gases.
4. Installation of a drip leg in the gas supply line going to each heater is required to minimize the possibility of any loose scale or dirt within the gas supply line from entering the heater's control system.
5. When checking for gas leaks, do not use an open flame. Use a soap and water solution.
6. For gas supply line pressures in excess of $\frac{1}{2}$ psig, consult the factory or your local representative.
7. Installation of $\frac{1}{8}$ " N.P.T. plugged tapping, accessible for test gage connections, is required upstream of the gas supply connection to the heater.

VENTILATION

1. It is recommended that a minimum building ventilation rate of four(4) CFM per 1000 BTUH of installed heater input be provided. This rate of ventilation may be obtained through either gravity or mechanical ventilation of the building.
2. In conjunction with building ventilation system, adequate fresh air into the building must be provided through fresh air inlets and/or building crackage.
3. It is recommended that the local authorities be contacted to assure the ventilating system and heater installation are in compliance with any applicable local and/or state codes.

HEATER OPERATION

Upon installation of the heater and completion of the gas and electrical supply line to each heater, follow the steps outlined on the "Lighting Instruction" plate located on the inside of the control door.

MAINTENANCE

In order to get the maximum performance from your heater, we recommend the following be performed at least annually. More frequent service and maintenance may be required if heater is located within 2,000 feet of a waterfront.

1. With an air hose regulated to 30 psig, blow off any dust and dirt that has accumulated around the burner and inside the control compartment of the heater. Proper eye protection required.
2. From the front of the heater, direct the air hose from a distance of approximately twelve (12) inches over the entire exposed area of each burner's ceramics
3. Do not insert air hose into the inlet of the burner.
4. Remove main burner orifice, clean and re-install.
5. Check to insure heater is securely mounted and the clearance from combustibile materials is maintained.
6. If additional service to the heater is required contact your local representative or the factory.

SEQUENCE OF OPERATION

Turn gas and power "ON." The pilot and burner should light within 4 seconds. A heat sensor will shut off the spark. If the burner does not light within 15 seconds, the heat sensor will shut "OFF" the gas valve. To relight the pilot and burner, shut "OFF" power. Wait 5 minutes. Turn power back "ON."



**MINIMUM CLEARANCE
TO COMBUSTIBLE MATERIALS
USING OPTIONAL MOUNTING KIT
P/N 12006**

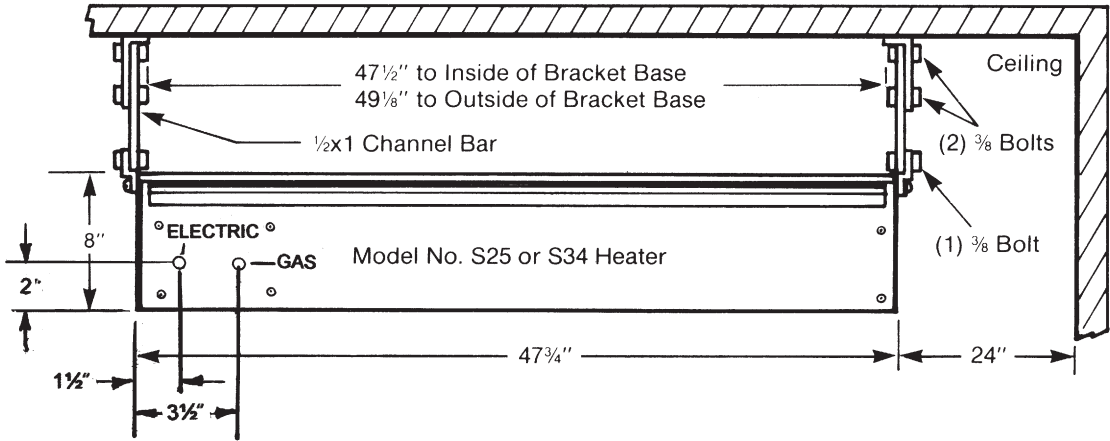
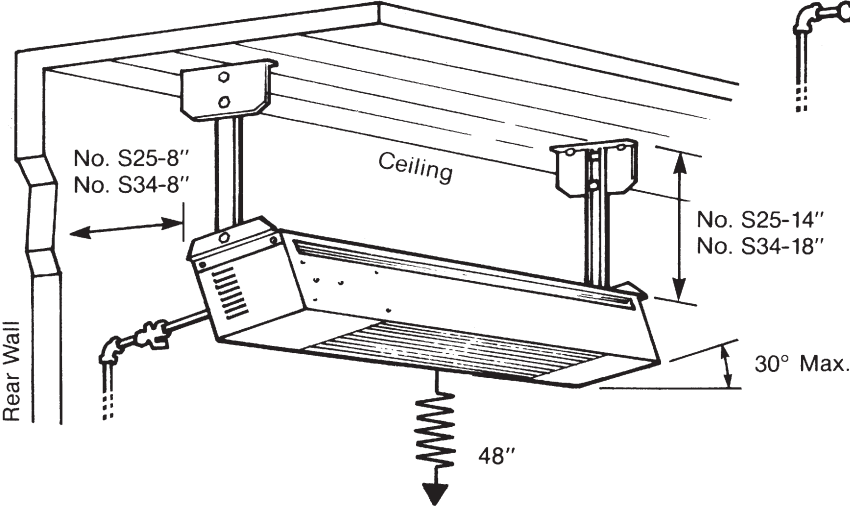
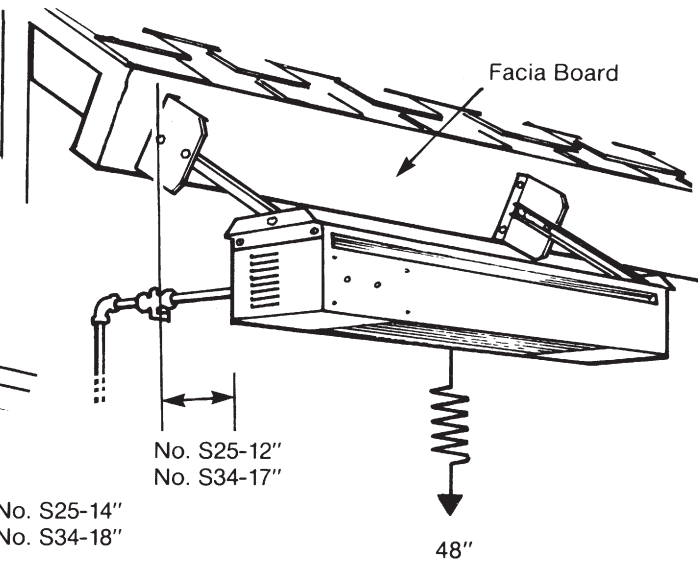
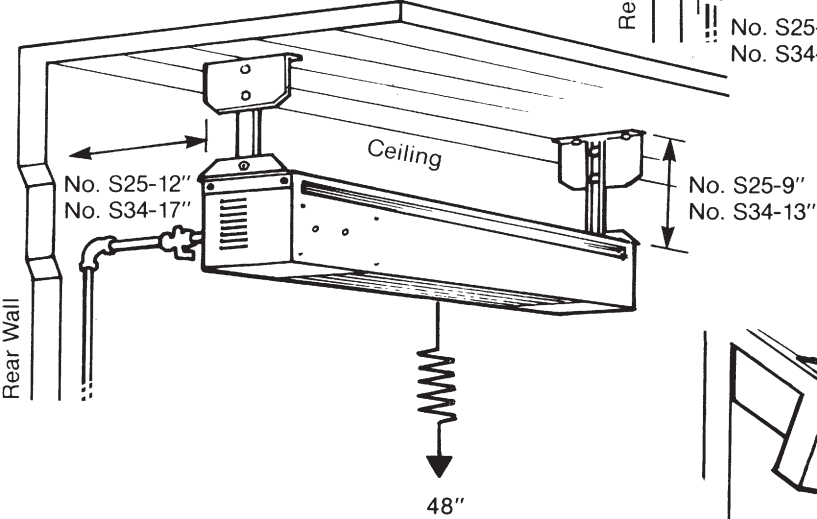
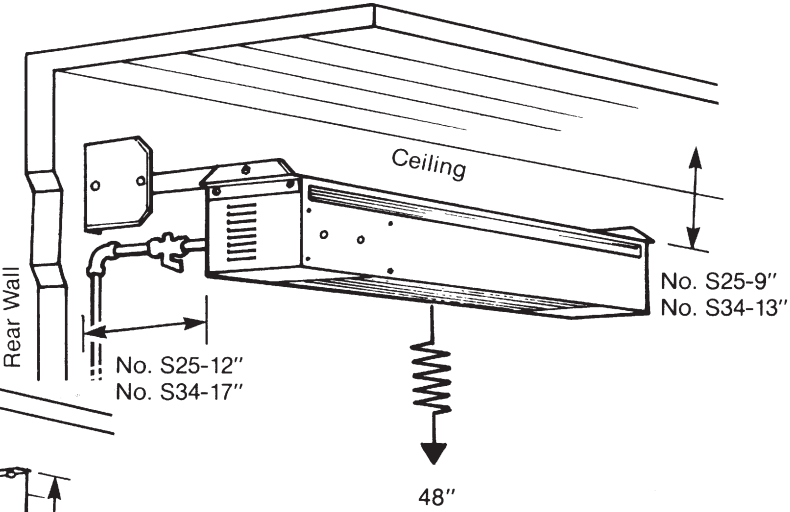

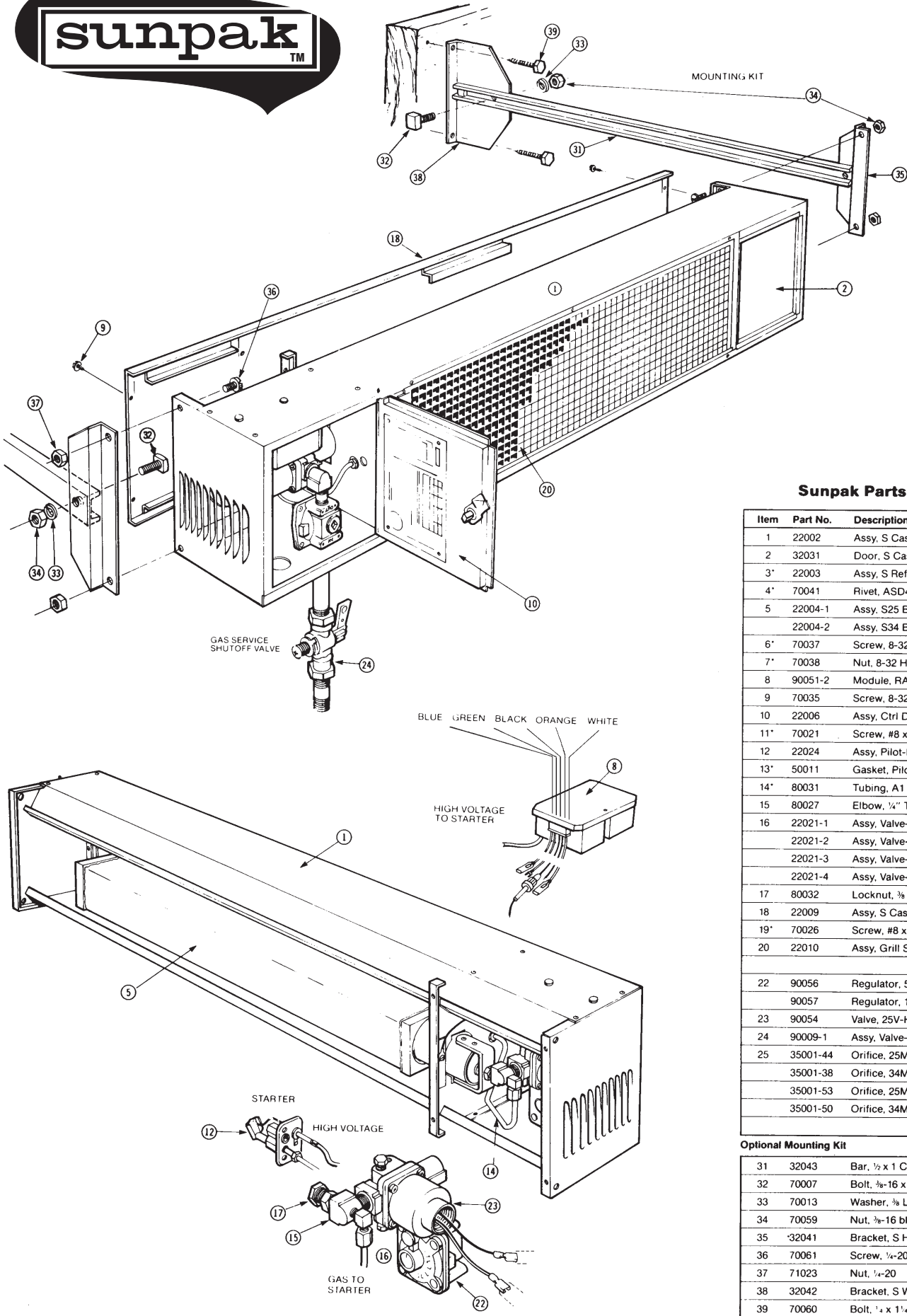

Sunpak Parts List

Item	Part No.	Description
1	22002	Assy, S Casing
2	32031	Door, S Casing Rear
3	22003	Assy, S Reflector
4	70041	Rivet, ASD42-1/8 x 1/4
5	22004-1	Assy, S25 Burner
	22004-2	Assy, S34 Burner
6	70037	Screw, 8-32 x 3/8 SPSS
7	70038	Nut, 8-32 Hex Zn
8	90051-2	Module, RAM-3 24 volts
9	70035	Screw, 8-32 x 2 1/4 SPMS, Blk
10	22006	Assy, Ctrl Door (less plate)
11	70021	Screw, #8 x 1/4 WHSM
12	22024	Assy, Pilot-Elect. 2SH76
13	50011	Gasket, Pilot
14	80031	Tubing, A1 1/4 x 14" L
15	80027	Elbow, 1/4" Tubing x 1/8 MPT
16	22021-1	Assy, Valve-Regular S25 Nat
	22021-2	Assy, Valve-Regular S34 Nat
	22021-3	Assy, Valve-Regular S25 LP
	22021-4	Assy, Valve-Regular S34 LP
17	80032	Locknut, 3/8
18	22009	Assy, S Casing Top
19	70026	Screw, #8 x 1/2 SP-SS
20	22010	Assy, Grill S
22	90056	Regulator, 5" W.C. Nat
	90057	Regulator, 10" W.C. LP
23	90054	Valve, 25V-H91CG-12
24	90009-1	Assy, Valve-Nipple
25	35001-44	Orifice, 25M-Nat
	35001-38	Orifice, 34M-Nat
	35001-53	Orifice, 25M-LP
	35001-50	Orifice, 34M-LP

Optional Mounting Kit

31	32043	Bar, 1/2 x 1 Channel 21-5/16" L
32	70007	Bolt, 3/8-16 x 1/4 Square Head
33	70013	Washer, 3/8 Lock
34	70059	Nut, 3/8-16 black zinc
35	32041	Bracket, S Heater
36	70061	Screw, 1/4-20 x 1/2 black zinc
37	71023	Nut, 1/4-20
38	32042	Bracket, S Wall
39	70060	Bolt, 1/4 x 1 1/4" L lag blk zinc

*Not shown

SEQUENCE OF OPERATION

Turn gas and power "ON." The pilot and burner should light within 4 seconds. A heat sensor will shut off the spark. If the burner does not light within 15 seconds, the heat sensor will shut "OFF" the gas valve. To relight the pilot and burner, shut "OFF" power. Wait 5 minutes. Turn power back "ON."

TROUBLE SHOOTING

Problem	Possible Causes
No Spark to Pilot	<ul style="list-style-type: none">• Voltage under 24VAC• Bad Fuse• Improper spark gap (7/64" or .109")• Loose ground wire• Broken Electrode• Faulty Electronic module
Burner Won't Light	<ul style="list-style-type: none">• Air in gas line• Low gas pressure• Bad Gas Valve• Blockage in gas line• Manual Gas Valve turned "OFF"
Inconsistent Operation	<ul style="list-style-type: none">• Variable gas pressure (improperly sized gas line)• Variable Voltage• Wind exceeding 15 mph• Tip angle exceeding 30°• Debris inside burner• Erratic winds
Deterioration of the Front Grill	Sunpak heaters must be installed in such manner as to allow the products of combustion or hot gases to vent out the top portion of the heater. When operating normally, only radiant heat passes through the front grill. If conditions exist which force hot gases through the front grill of heater, the installation must be altered to correct the condition.

Limited Warranty and Service

SUNPAK® Infrared Heaters carry a 90-day commercial or one-year residential limited factory warranty. All heaters are stamped with the date of manufacture. In most cases, your dealer or sales representative will handle the warranty procedure for you. If there is no sales representative available, the heater may be returned to the factory for repair. Warranty is limited to repair of heaters at the factory or replacement parts. Any work or repair of this heater must be performed by qualified service personnel. Infrared Dynamics will not be liable for any other expense to the customer, except as stated above.



Sunpak® is a Registered Trademark of Infrared Dynamics, Inc.

3830 Prospect Ave.
Yorba Linda, CA 92886 U.S.A.
Tel: (714) 572-4050
Fax: (714) 572-6093