

INSTRUCTIONS

DAYVA PREMIERE OUTDOOR HEATER

Model HS041-2

By



The Dayva Premier Outdoor heater is another fine product from Dayva International. Dayva is the leader in accessories for the outdoor market. Dayva prides itself in delivering quality products at reasonable prices for almost 30 years.

Thank you for choosing Dayva!

Manufactured Exclusively for Dayva International



7441 Vincent Circle, Huntington Beach, CA 92648
Tel: 714-842-9697 • Fax: 714-842-5759
E-mail: dayva@dayva.com • www.dayva.com

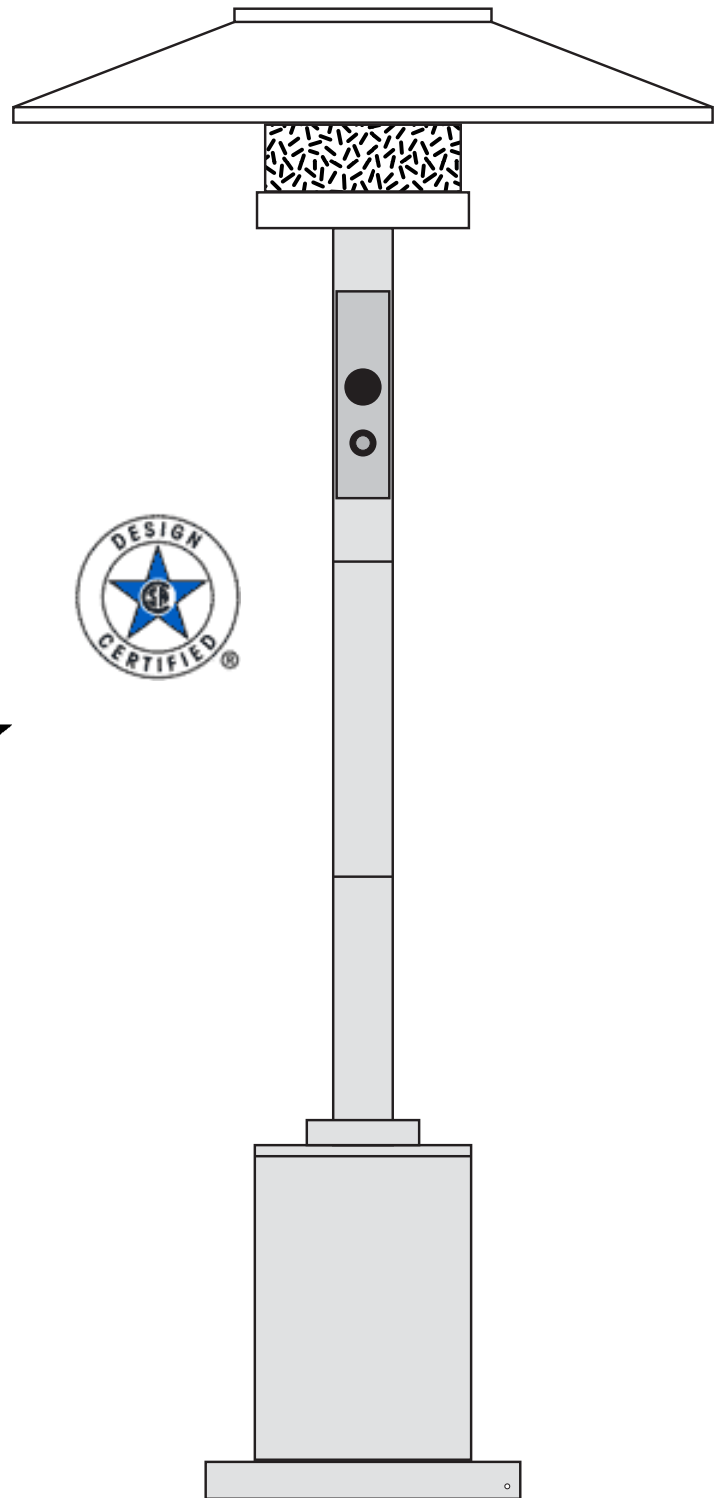

US Patent # 325,963
Other US Patents Pending.
Foreign Patents Pending.

Assembly, Installation & Instruction Manual

DAYVA PREMIERE

OUTDOOR HEATER

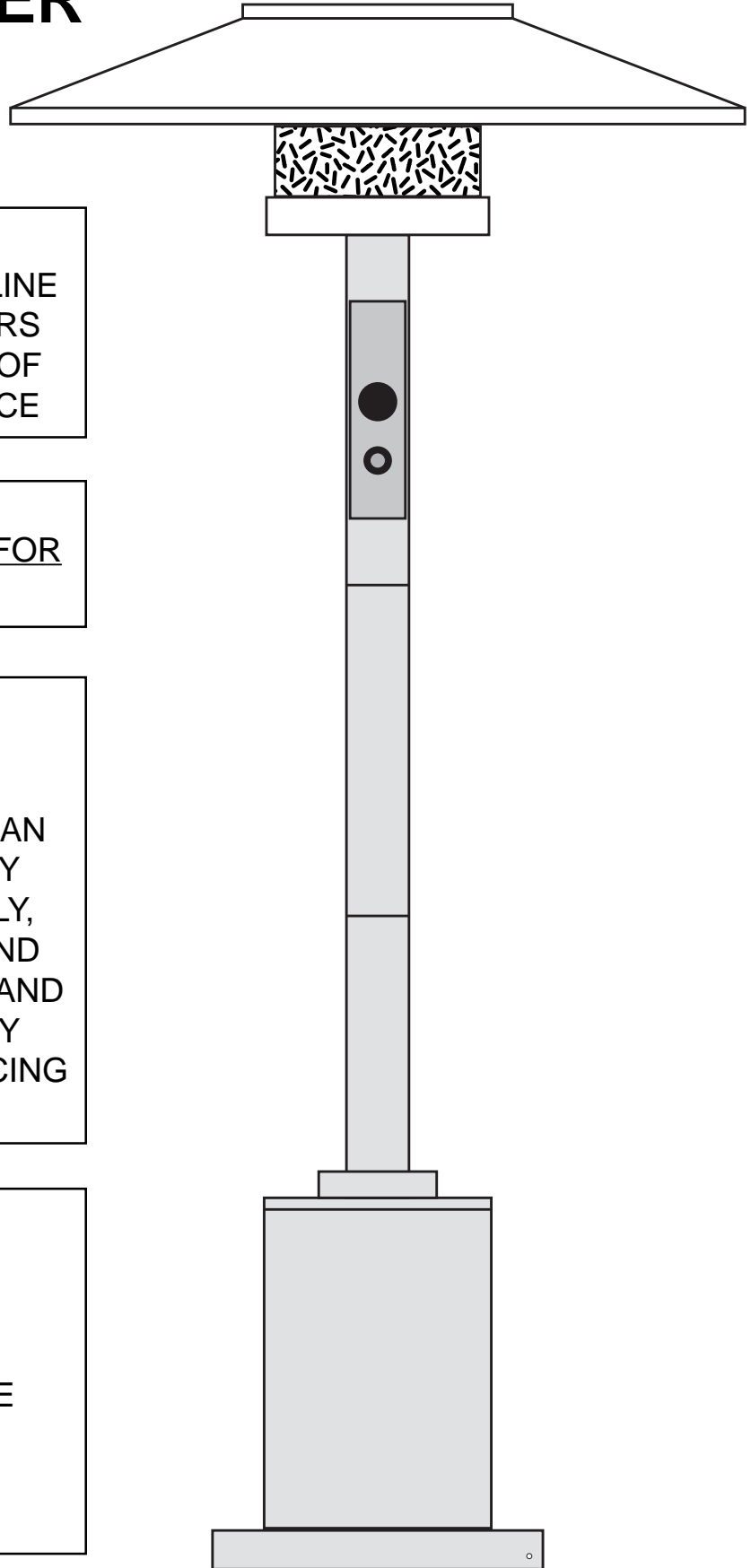

FOR YOUR SAFETY:

DO NOT STORE OR USE GASOLINE OR OTHER FLAMMABLE VAPORS AND LIQUIDS IN THE VICINITY OF THIS OR ANY OTHER APPLIANCE

WARNING:

THIS APPLIANCE IS DESIGNED FOR OUTDOOR USE ONLY

WARNING:

IMPROPER INSTALLATION, ADJUSTMENT, ALTERATION, SERVICE, OR MAINTENANCE CAN CAUSE INJURY OR PROPERTY DAMAGE. READ THE ASSEMBLY, INSTALLATION, OPERATING, AND MAINTENANCE INSTRUCTIONS AND ALL WARNINGS THOROUGHLY BEFORE INSTALLING OR SERVICING THIS EQUIPMENT

FOR YOUR SAFETY:

IF YOU SMELL GAS:

1. SHUT OFF GAS TO THE APPLIANCE
2. EXTINGUISH ANY OPEN FLAME
3. IF ODOR CONTINUES, IMMEDIATELY CALL YOUR GAS SUPPLIER

Things to know about your 40,000 BTU Dayva Premier Outdoor Heater

Radiant Heat at 40,000 BTU's:

The Dayva Premier Outdoor Heater generates “Radiant Heat.” Heated air goes up and radiant heat is reflected down. This kind of heat is undisturbed by wind. It's, light, it moves in waves. People absorb this light; the warming sensation on your skin is caused by light waves. The more intense the BTU's, the closer the light waves are, the more individuals will feel a warming sensation. The ambient temperature around the heater is equal to 40,000 BTU's after burning for five minutes. The Dayva Premiere Outdoor Heater features an adjustable control valve, allowing for a desired heat output. Whether a cozy dinner on the patio or those large gathering, you'll always have the right heat.

Burner Characteristics:

The Dayva Premier Outdoor Heater burns with a blue flame being 2”-3” and a yellow/orange tip. The emitter will glow a hot red, radiating heat to the hood and down with warmth for you.

Safety Tilt Feature:

Dayva Premiere Outdoor Heater come with a Safety Tilt feature that will shut off the gas if the heater tilts over or is knocked down. This unique safety feature is just another comfort for your peace of mind.

Care of L.P. (Propane) Gas Cylinders

(Not included)

WARNING:

**L.P. GAS CANNOT AND SHOULD NOT BE USED ON UNITS
EQUIPPED FOR NATURAL GAS.**

If your heater is designed for use with an L.P. cylinder (not included), the cylinder must meet the following requirements:

- Cylinder weight is 20 lb. (9.07 kg); cylinder has outside diameter of 12-1/8 in. (30.8 cm), length of 18 in. (45.7 cm) and is constructed and marked to specifications of the U.S. Department of Transportation (D.O.T.) or Canadian Transport Commission (C.T.C.). Cylinder has shut-off valve outlet which is a No. 510, female P.O.L.; a safety relief device which has direct communication with vapor space of cylinder. Supply system is arranged for vapor withdrawal. Cylinder includes a collar to protect valve. When use with L.P. gas, special precautions should be observed when handling L.P. cylinders. Remember that this is gas and under pressure, which **MUST** be handled with care. Ask your L.P. gas dealer to give you a "short course" on necessary safety precautions and check local codes for use, storage and transport regulations. Among the recommended practices are:
 1. Always keep L.P. cylinders upright.
 2. Do not subject L.P. cylinders to excessive heat.
 3. Avoid damage to tank valves - handle them with care.
 4. Never store L.P. cylinders indoors or in direct sunlight.
 5. Do not handle L.P. cylinders roughly.

Follow instructions for connecting and disconnecting L.P. cylinders for the heater and be sure to leak check all connections each time the cylinder is connected. Always use a solution of soap and water.

NEVER USE AN OPEN FLAME!

Always turn off the gas supply to the heater at the cylinder as soon as you are finished using the heater. The L.P. cylinder must be equipped with the pressure regulator and hose assembly supplied with the heater. The pressure regulator is set at the factory for maximum efficiency.

Visually inspect the entire length of the hose for damage before use. This requires opening the door of the L.P. cylinder enclosure. If damage or excessive wear is found, replace the regulator assembly immediately. If needed, order only factory original parts. Do not attempt to substitute parts.

Always store L.P. Cylinders in a well ventilated space. If you intend to store the heater indoors, disconnect the L.P. Cylinder and store it outside. Disconnected cylinders must have a threaded valve plug tightly installed. When the L.P. Cylinder is not disconnected from the heater, the heater and cylinder must be stored outdoors in a well ventilated space, out of the reach of children.

If you have not purchased an Auto-Stop Fill Tank, never allow your cylinder to be filled above the liquid level stop fill gauge. The P.O.L. service valve and liquid level gauge are designed to be closed leak-tight by hand. If wrenches are necessary to stop a leak, the valve probably needs repair or replacement.

Check all cylinder and line connections periodically to be sure they are tight. Make certain your cylinder is properly fastened in place with the tank safety strap.

FOR YOUR SAFETY READ BEFORE OPERATING

WARNING:

If you do not follow these instructions exactly, a fire or explosion may result causing property damage, personal injury or loss of life.

- A. This appliance operates with a Safety Pilot System. It is important that the pilot lights before the burner can light.
- B. BEFORE OPERATING, smell all around the appliance area for gas. Be sure to smell next to the floor because some gas is heavier (PROPANE) than air and will settle on the floor. (NATURAL GAS WILL RISE)

WHAT TO DO IF YOU SMELL GAS

- Do not try to light any appliance.
 - Do not touch any electric switch; do not use any phone in your building.
 - Immediately call your gas supplier from a neighbor's phone. Follow the gas supplier's instructions.
 - If you cannot reach your gas supplier, call the fire department.
- C. Use only your hand to push in or turn the gas control knob. Never use tools. If the knob will not push in or turn by hand, don't try to repair it, call a qualified service technician. Force or attempted repair may result in a fire or explosion.
 - D. Do not use this appliance if any part has been under water. Immediately call a qualified service technician to inspect the appliance and to replace any part of the control system and any gas control which has been under water.
 - E. Quick disconnects are not recommend because of possible gas leaking from connections.

CHOOSING A LOCATION

The heater may be installed on a combustible floor surface. If the heater is installed near a combustible wall or ceiling surface, the following minimum clearances must be maintained: 18 in. from any ceiling surface, and 24 in. from any wall on all sides.

This appliance is CSA Certified for outdoor installation **only** in a well ventilated space. The installation of this appliance must conform with local codes or, in the absence of local codes, with the National Fuel Gas Code, ANSI Z223.1-Latest Edition. It must not be used in a building, garage, or any enclosed area or structure. The ground surface used for installation must be firm and level, and allow adequate ventilation around the unit (a minimum of 24 in. clear per side). At no time should any part of the L.P. cylinder enclosure be blocked off.

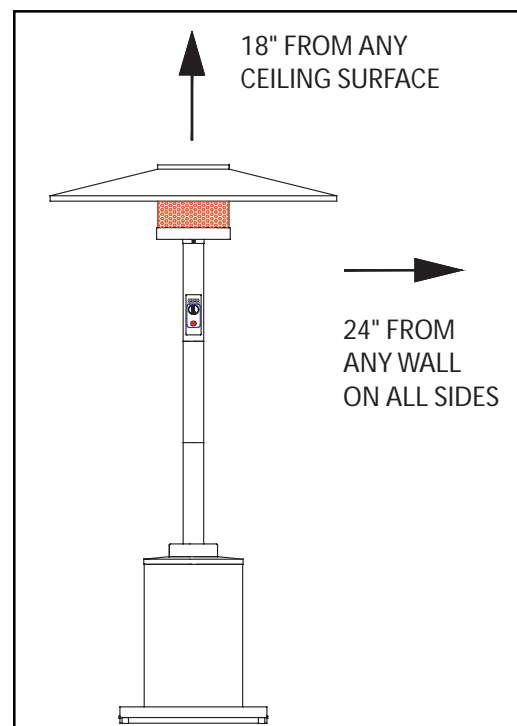

WARNING

This product must be assembled and tested as shown in these instructions. Any deviation or lack of testing could cause personal or property damage. If you feel unable to assemble or test your heater as described, have a qualified professional do it for you.

FOR TESTING INSTRUCTIONS SEE PAGE 11

DAYVA PREMIERE OUTDOOR HEATER

**MODEL
HS041-2**



Tools Required

Phillips screwdriver, adjustable wrench / or pliers.

Step 1

Unpack the box and flatten it out on the ground where you will be working. This will provide you with a clean and non-abrasive work surface.

DAYVA PREMIERE OUTDOOR HEATER

CONTENTS PACKED IN (2) BOXES

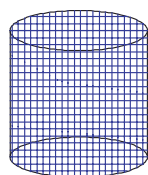
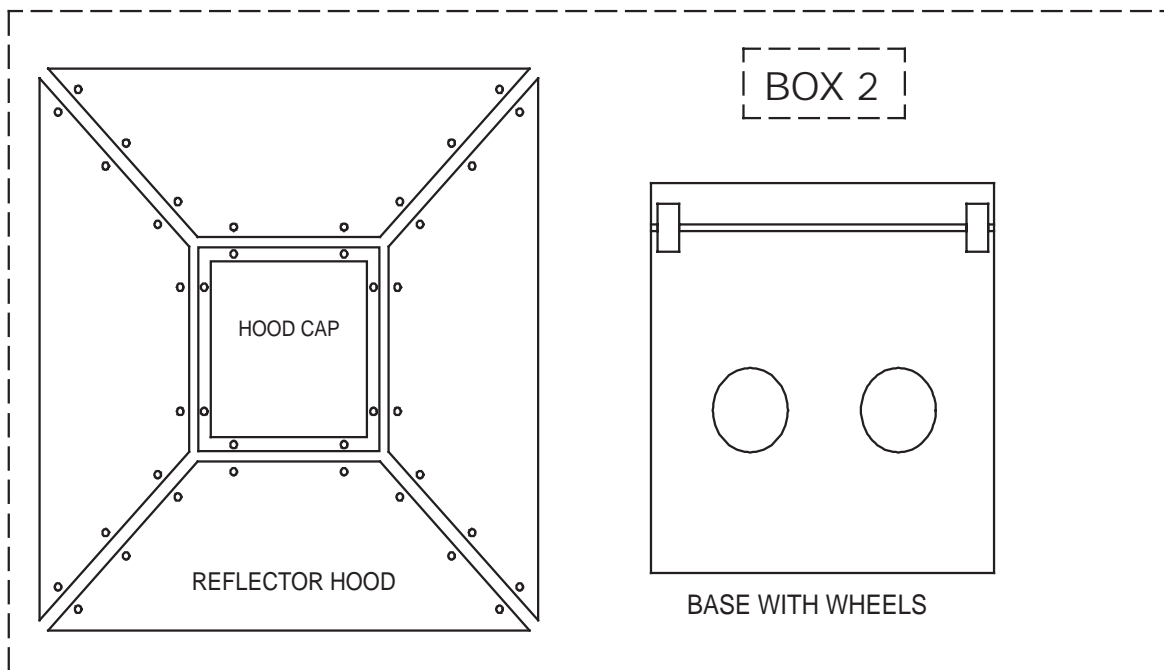

EMITTER
SCREEN

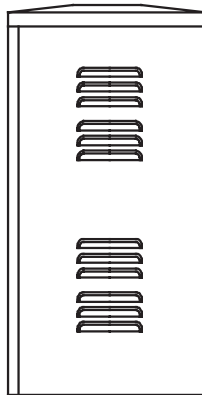

TANK CABINET

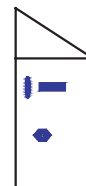

ASSEMBLY
PARTS
KIT

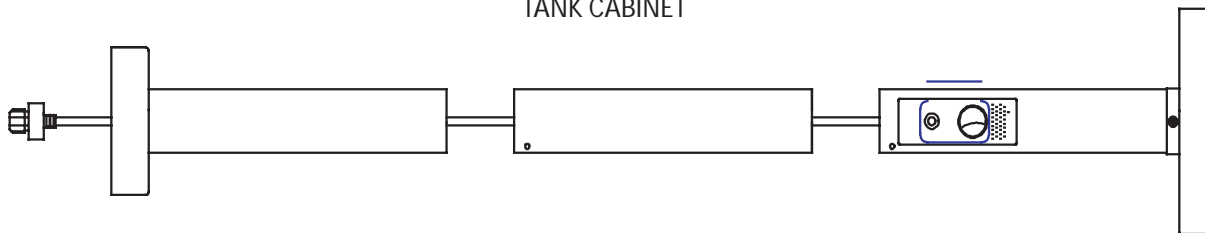

ASSEMBLY PARTS SUPPLIED

- (50) #10-32 x 1/2" Screws
- (50) Lock Washers
- (16) #10-32 Nuts
- Tank safety strap and buckle
- Igniter with hex nut
- Regulator
- Instructions

Substitutions may be made

DAYVA PREMIERE OUTDOOR HEATER

Step 2

Slip the connector hose through the two pieces of the heater post, as shown. The connector will be factory assembled to the top heater post piece. Slide all three pieces together and secure with the screws provide, as illustrated below. Make sure the holes for the screws line up when sliding the pieces together.

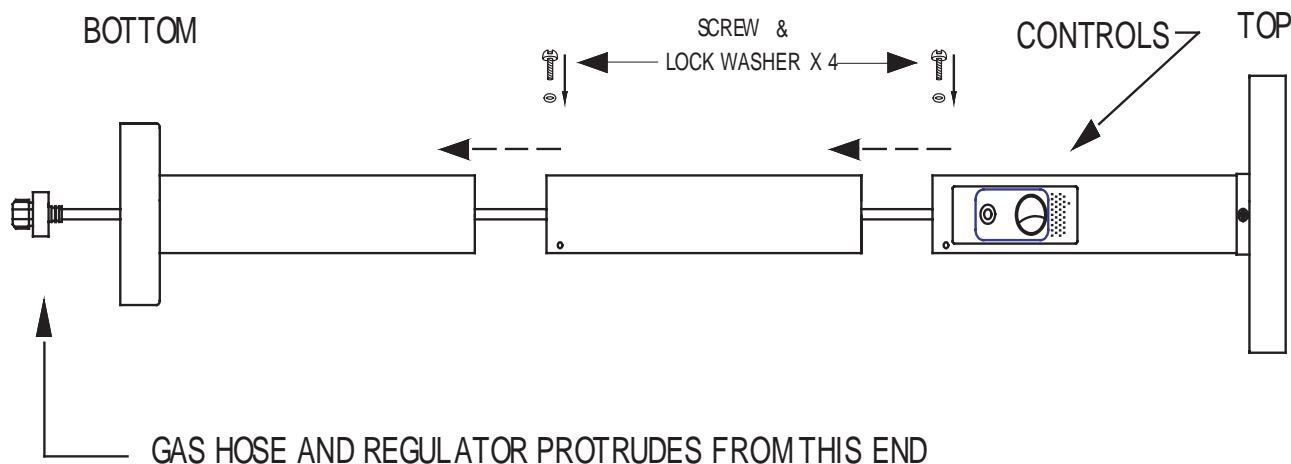

Step 3

Place the cabinet on the base so that the three threaded studs pass through the mounting holes in the cabinet. Once the cabinet is in position over the studs, place a 1/4" nut on each stud and tighten securely with a wrench.

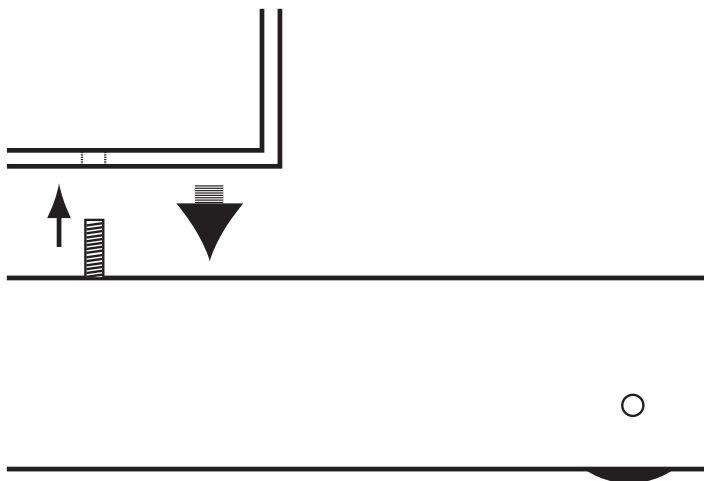

DAYVA PREMIERE OUTDOOR HEATER

Step 4

Carefully lower the assembled heater post onto the cabinet. Secure with four screws.

Step 5

While the cabinet door is open, locate the tank strap mounting slots on the sides of the cabinet. Install the tank safety strap through these slots.

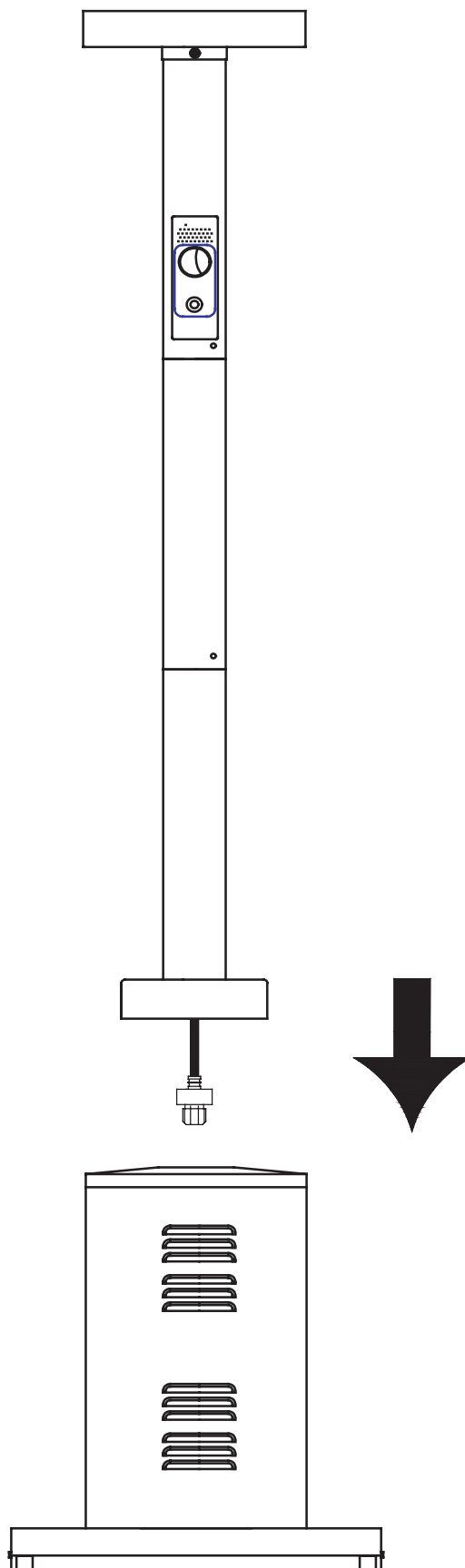

DAYVA PREMIERE OUTDOOR HEATER

Step 6

Turn the hood upside down on your cardboard work surface. Place the emitter screen in the center of the hood and align the mounting holes. From the outside, insert four screws. From the inside, install one lock washer and one hex nut on each screw. Tighten securely.

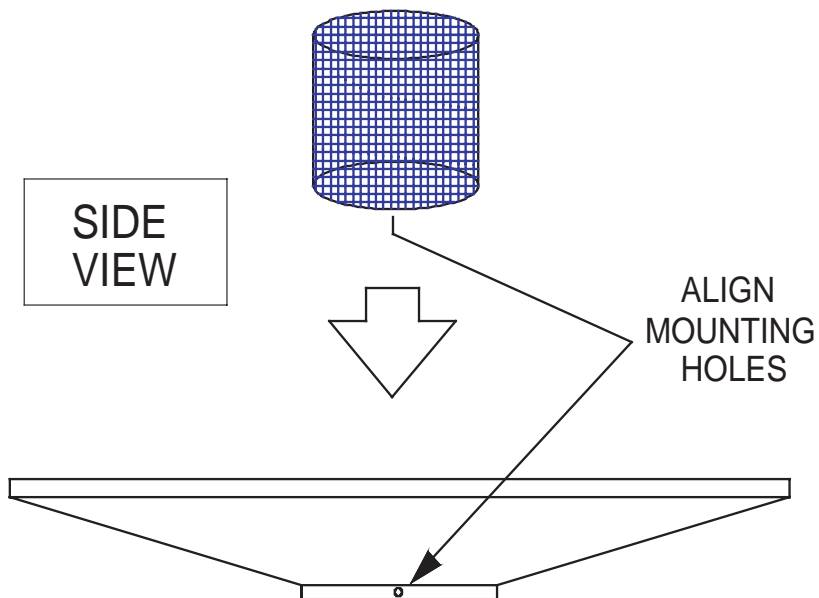

Step 7

Turn the hood/emitter screen assembly over and place it on the heater post. Make sure all four of the mounting tabs are inside the emitter screen. Line up holes in screen with tabs.

Install four screws and tighten securely.

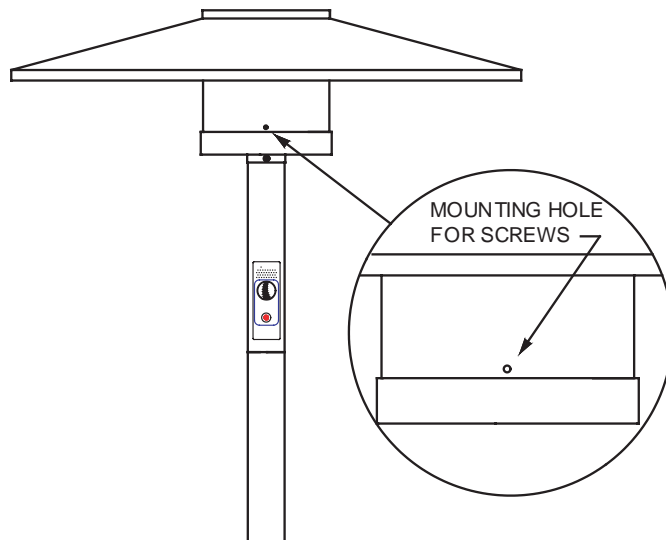

DAYVA PREMIERE OUTDOOR HEATER

STEP 8 - TESTING PROCEDURE FOR PROPANE

- Prepare a cup of very soapy water.
- Attach Regulator to your L.P. Tank. Tighten securely with a wrench or the handwheel (if provided). Leave the L.P. Tank outside of the Cabinet for the testing procedure.
- Open the valve on the L.P. Tank. Leave the Heater Valve in the “OFF” position.
- With a brush or sponge, apply the soap and water mixture liberally to the union (junction) between the Regulator and the L.P. Tank, and the union between the Regulator and the Valve Fitting.
- Any leaks will blow soap bubbles.
- Repair any and all leaks by tightening union with wrench.
- Once any and all leaks have been stopped, the heater is ready for use!

**DO NOT USE A FLAME
FOR LEAK TESTING**

TESTING PROCEDURE FOR NATURAL GAS

- Prepare a cup of very soapy water.
- Attach heater gas hose to gas supply line. Tighten securely with a wrench .
- Open the gas supply line valve. Leave the Heater Valve in the “OFF” position.
- With a brush or sponge, apply the soap and water mixture liberally to the union between the supply line and heater valve. Any leaks will blow soap bubbles.
- Repair any and all leaks by tightening union with wrench.
- Once any and all leaks have been stopped, the heater is ready for use!

**DO NOT USE A FLAME
FOR LEAK TESTING**

DAYVA PREMIERE OUTDOOR HEATER

WARNING:

GAS LEAKS ARE EXTREMELY DANGEROUS AND POTENTIALLY EXPLOSIVE! DO NOT USE THIS PRODUCT IF A LEAK CANNOT BE REPAIRED.

THE ABOVE TEST MUST BE PERFORMED EVERY TIME THE L.P. TANK IS CHANGED.

IF YOUR HEATER DEVELOPS A LEAK THAT CANNOT BE REPAIRED, YOU MAY REQUIRE REPLACEMENT PARTS OR A NEW L.P. TANK. DISCONTINUE USE UNTIL THE NEW PARTS ARE INSTALLED.

IF YOU SMELL GAS, DISCONTINUE USE UNTIL THE LEAK IS IDENTIFIED AND REPAIRED.

Step 9

With the assembly and testing complete, carefully place the L.P. Tank inside the cabinet. Do not drag or push the tank inside. This may cause damage to the paint finish.

Attach the tank safety strap.

Follow the lighting instructions on the following page.

DAYVA PREMIERE OUTDOOR HEATER

FOR YOUR SAFETY READ BEFORE OPERATING

Important safety instructions which if not followed could endanger the personal safety and/or property of yourself and others. Read and follow all instructions before attempting to operate your Dayva Premier Outdoor Heater.

The minimum inlet gas supply pressure for the purpose of input adjustment pressure:

LP (Propane) Gas 11.2 inches w.c.

Natural Gas 10.0 inches w.c.

The maximum inlet gas supply pressure for the purpose of input adjustment pressure:

LP (Propane) Gas 1/2 PSI

Natural Gas 1/2 PSI

The required manifold pressure in inches of water column:

LP (Propane) Gas 10.0 w.c.

Natural Gas 7.0 inches w.c.

WARNING:

Certain materials or items when stored under the heater, will be subjected to radiant heat and could be seriously damaged.

Lighting, shutdown and control operations:

After fully assembling your Dayva heater, turn on main gas supply and carefully recheck all fittings for leakage using soap/water solution (see page 10).

If leak is discovered, turn off gas immediately. Repair seal on fitting with standard pipe seal compound certified by a regulatory agency resistant to LP Gas.

A. Make certain main gas supply shut-off valve is in the "ON" position.

B. Push and turn gas control dial to "OFF" Position.

C. Wait sufficient length time to allow gas which may have accumulated to escape.
(at least 5 minutes)

D. Push and turn Gas Control Dial to "ON" position. Depress and hold dial in while pushing red igniter button several times until pilot lights.

E. Allow burner to burn approximately 30 seconds before releasing dial. If pilot does not remain burning when dial is released, repeat operation allowing longer period before releasing dial. Wait a sufficient length of time (at least 5 minutes) to allow gas which may have accumulated to escape. Repeat lighting instructions. If burner still will not light see "TROUBLE SHOOTING", (pages 16-17).

DAYVA PREMIERE OUTDOOR HEATER

Complete Shutoff:

Turn Gas Control Dial to "OFF" position and close the main gas supply shutoff valve on LP Tank or the Natural Gas Supply source.

Warning:

The emitter and hood area becomes very hot during operation; stay away to avoid burns or clothing ignition.

Young children should be carefully supervised when they are in the area of the heater.

Clothing or other flammable materials should not be hung from the heater, or placed on or near the heater.

Any guard or other protective device removed while servicing the heater must be replaced prior to operating the heater.

Installation and repair should be done by a qualified service person. The heater should be inspected before use and at least annually by a qualified service person. More frequent cleaning may be required as necessary. It is imperative that the control compartment, burner, pilot and circulating air passageways of the heater be kept clean.

Maintenance:

Frequency checks:

A. Keeping the heater area clear and free from combustible materials, gasoline and other flammable vapors and liquids.

B. Not obstructing the flow of combustion and ventilation air.

C. Keeping the ventilation openings of the cylinder enclosure free and clean from debris.

D. Visually inspect burner flames

Cleaning:

See page 19 for cleaning instructions.

Complete Shutoff:

Visually check the burner flame each time the heater is used. Flames should be blue with yellow tips.

Possible causes of a poor flame:

1. Burner is clogged. Remove and clean the burner.
2. Air passageways clogged with debris
3. Tank is low. Refill tank.

LIMITED WARRANTY

Dayva International, Inc., extends a one-year warranty from the date of purchase against manufacturing defects in material and workmanship to the original purchaser of this product. If this product fails to operate because of a manufacturing defect, the defective part will be repaired or replaced at Dayva International, Inc.'s option, send the defective part, along with proof of purchase, to Dayva International Inc., shipping prepaid.

This warranty does not apply to defects caused by accidental damage, improper handling, installation, modification, or improper connection to gas source, and specifically excludes liability for indirect, incidental or consequential damage to property. Some states do not allow the exclusion or limitation of incidental or consequential damages, so the above exclusion or limitation may not apply to you. This warranty gives you specific legal rights, and you may also have other rights which vary from state to state.

Dayva International, Inc., 7441 Vincent Circle, Huntington Beach, CA 92648
Phone: 714-842-9697 Fax: 714-779-5759

DAYVA PREMIERE OUTDOOR HEATER

CONSTRUCTION DIAGRAM HS041-2

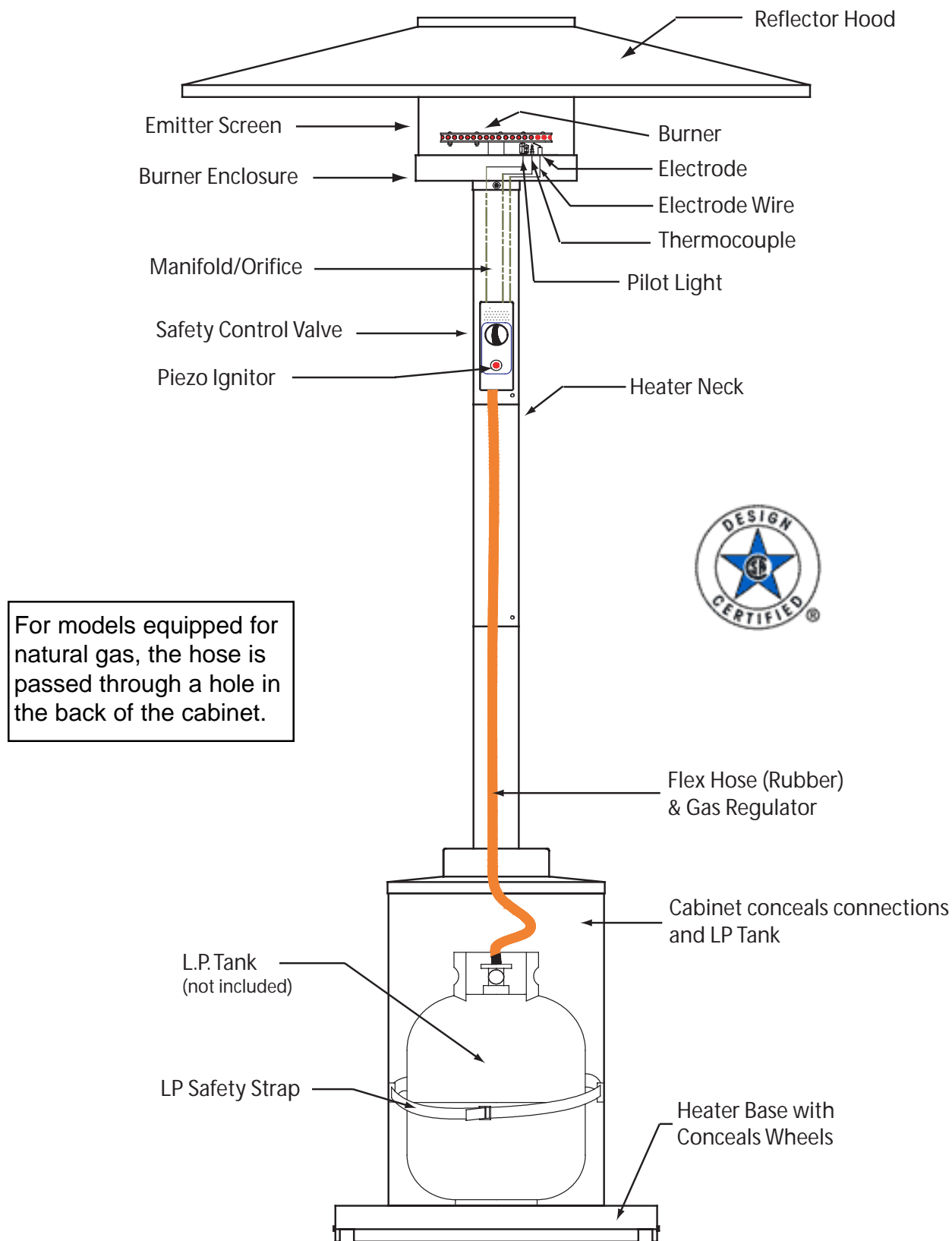

Place heater on a firm and level surface

DAYVA PREMIERE OUTDOOR HEATER

TROUBLE SHOOTING

PROBLEM 1

Burner won't remain lit.

CAUSE A

Possible Leak

SOLUTION

Check all connections

1. Use liquid soap to find leaks. Pour over connection between hose and regulator and regulator to tank. If soap bubbles, leaks are present.

* With all Propane tanks in the US, if a leak is present the tank will automatically shut-down.

2. Use teflon tape on all connections.

3. Tighten all connections.

4. Check for leaks again. **NEVER USE AN OPEN FLAME TO CHECK FOR LEAKS.**

4 Re-light heater to test.

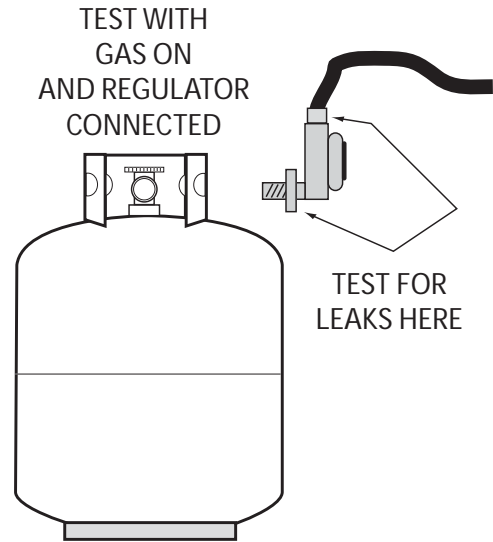

CAUSE B

Thermocouple may be too tight on valve.

* If thermocouple is too tight on valve, it will limit the amount of millivolt electricity, which keeps the valve flowing gas.

SOLUTION

Loosen Thermocouple

1. Remove cover opposite side the control knob with phillips screwdriver.

2. With a wrench, loosen thermocouple connection to valve (Copper lead with 1/4" flare fitting)

3. Hand tighten and slightly tighten with wrench. Do NOT torque or over tighten.

4. Re-light heater to test.

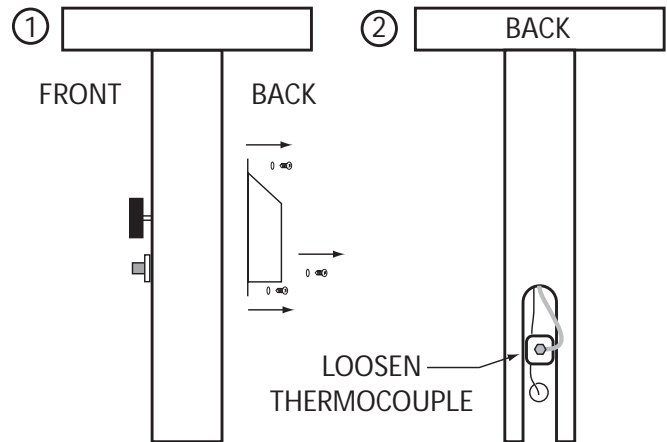

CAUSE C

An Obstruction may be in the Orifice (see illustration #4 on page 2)

* An obstruction will make the gas flow improperly and prevent the flame from touching the thermocouple properly.

SOLUTION

CLEAN THE ORIFICE (as explained for Problem #2)

DAYVA PREMIERE OUTDOOR HEATER

TROUBLE SHOOTING

PROBLEM 2

Large Yellow Candlering Flame

CAUSE

This can occur after a period of non-use. Most likely debris, dirt or a spider web has gotten into the orifice.

SOLUTION

CLEAN THE ORIFICE

1. Remove the hood and emitter by removing the (4) screws that attach the emitter screen to the burner plate.
 2. For easier access, also remove the top section of the post. This can be accomplished by first removing the regulator from the hose. Then remove the top neck portion from the post.
 3. With phillips screwdriver, remove the bracket holding the thermocouple and electrode (igniter) in place. Once removed, push both to the side, free from the burner.
 4. With channel locks, remove each screw (2), located directly under the burner, by turning counter-clockwise.
 5. Pull burner free from burner plate.
 6. The Orifice will now be exposed.
 7. Examine for debris, dirt or spider webs and clean as necessary.
- * Make sure not to push obstruction farther down orifice.
8. Once cleaned, re-assemble burner to burner plate, thermocouple and electrode to bracket, top neck section to post and regulator to hose.
 9. Make sure to use teflon tape when re-attaching regulator.
 10. Check for leaks (refer to Solution for Problem 1, Cause A).
 11. Re-light heater to test.

Please also reference the Instruction Manual for further Trouble Shooting information.

If neither Trouble Shooting Guide remedies the problem, please contact your Dayva retailer or Dayva International.

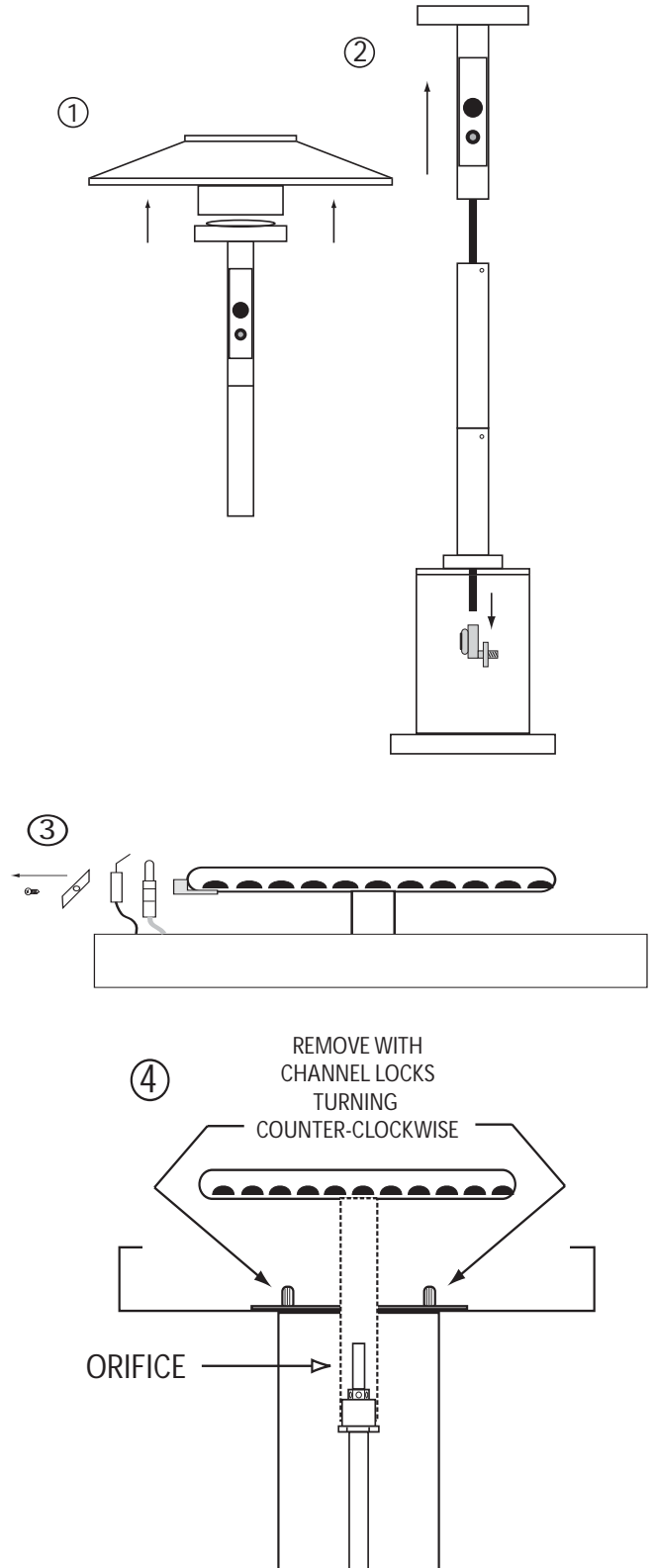

DAYVA PREMIERE OUTDOOR HEATER

TROUBLE SHOOTING

PROBLEM 3

Ignitor not lighting pilot

CAUSE

Electrode not creating a sufficient enough spark to ignite the gas

SOLUTION

CHECK SPARK GAP AND ELECTRODE CONNECTIONS

1. Remove the hood and emitter by removing the (4) screws that attach the emitter screen to the burner plate.
2. Check the spark gap and adjust as illustrated.
3. Check all Electrode wire connections.

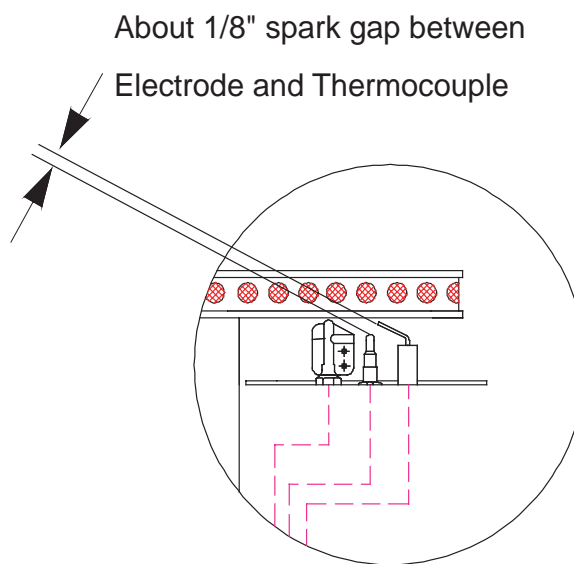

CARE & CLEANING

Cleaning the Heater

Follow the Trouble Shooting Guide for CLEANING THE ORIFICE. This should be done at least once a year, more if a problem occurs.

Open the Heater Access Plate, located opposite of the Controls and clean any debris from inside the neck. Make sure to pay special attention to the valve and ignitor.

The Emitter Screen can be cleaned with products like Oven Cleaners.

Cleaning the exterior surfaces and hood

You can wash your heater just like a car. Use mild detergent and rinse with water.

Keeping your heater clean allows it to operate and provide years of service.

If a scratch occurs in a powder coated surface, quickly touch-up with an exterior acrylic based paint. Touching up will lessen the possibility of rusting in that area.

Dayva International, unfortunately does not supply touch-up paint.

DAYVA PREMIERE OUTDOOR HEATER

COMMON REPLACEMENT PARTS MODEL HS041-2

| PART NUMBER | DESCRIPTION | NOTES |
|-------------|------------------------------|------------------------|
| HS019 | HOOD ASSEMBLY | INCLUDES HARDWARE |
| HS030-1 | PIEZO IGNITER | FOR NATURAL & LP UNITS |
| HS030-2 | WIRE & ELECTRODE FOR IGNITER | FOR NATURAL & LP UNITS |
| HS030-3 | THERMOCOUPLE | FOR NATURAL & LP UNITS |
| HS030-5 | CONTROL KNOB | FOR NATURAL & LP UNITS |

Contact the selling dealer or Call 714-842-9697 for current pricing, shipping and to place and order, for the above parts *only*.



7441 Vincent Circle, Huntington Beach, CA 92648

Tel: 714-842-9697 • Fax 714-842-5759

E-mail: dayva@dayva.com • www.dayva.com