

**Endless Summer**® 

# Cleaning Instructions for Burner, Pilot Assembly, and Emitter Screen



Series:  
150000 – 200605  
LP Gas





## Tools needed

- Bottle brush
- Non-abrasive scouring pad
- Small utility brush
- Heavy-duty pipe cleaners
- Air hose or can of compressed air
- Rubber gloves
- Soap and water solution (to check for leaks)
- #2 Phillips screwdriver
- Open-end wrenches (Sizes: #10mm / #12mm)
- 3/4 open end wrench
- 11/16 open end wrench
- Wrench
- Pliers
- Electrical tape
- Leak test solution 1 part liquid soap and 3 parts water.

### **DANGERS and *Cautions***

- 1. Installation and repair should be done by a qualified service person.**
- 2. Use only Blue Rhino Global Sourcing, LLC. factory authorized parts. The use of any part that is not factory authorized can be dangerous. This will also void your warranty. Contact 1.800.762.1142.**
- 3. Do not use flammable solutions or material to clean heater or heater parts. Use only warm soapy water to clean outside of heater.**
- 4. Do not submerge control valve in water.**



# Steps 1-4

1. Disconnect and remove propane cylinder from heater.
2. Disconnect the main gas line from engine
3. Remove dome.
4. Remove engine from post.



## Step 5

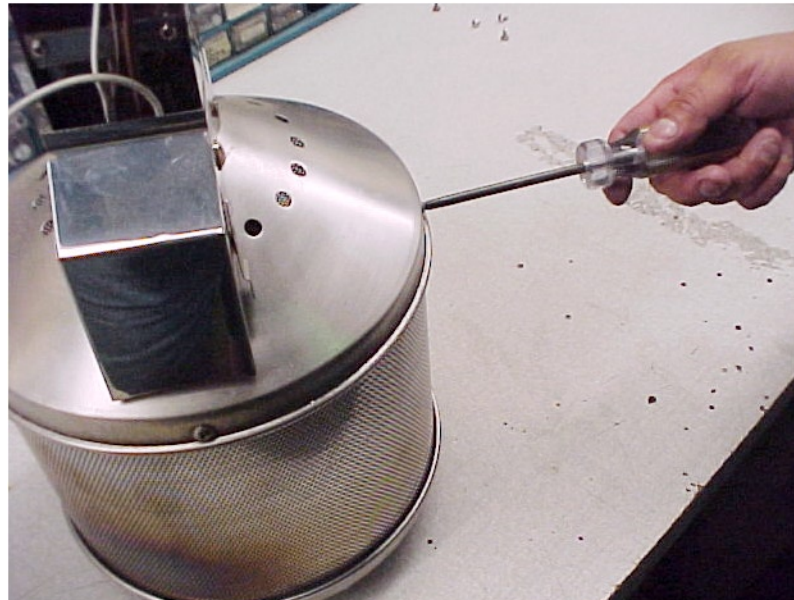

Remove emitter from emitter bottom by removing the 4 Phillips head screws in the emitter bottom.



## Step 6



Use a non-abrasive scouring pad with soap and water solution to clean the inside and outside of the emitter screen.



## Step 7



Unscrew and remove the two Phillips head screws in the pilot shield housing to remove the pilot shield.



## Step 8

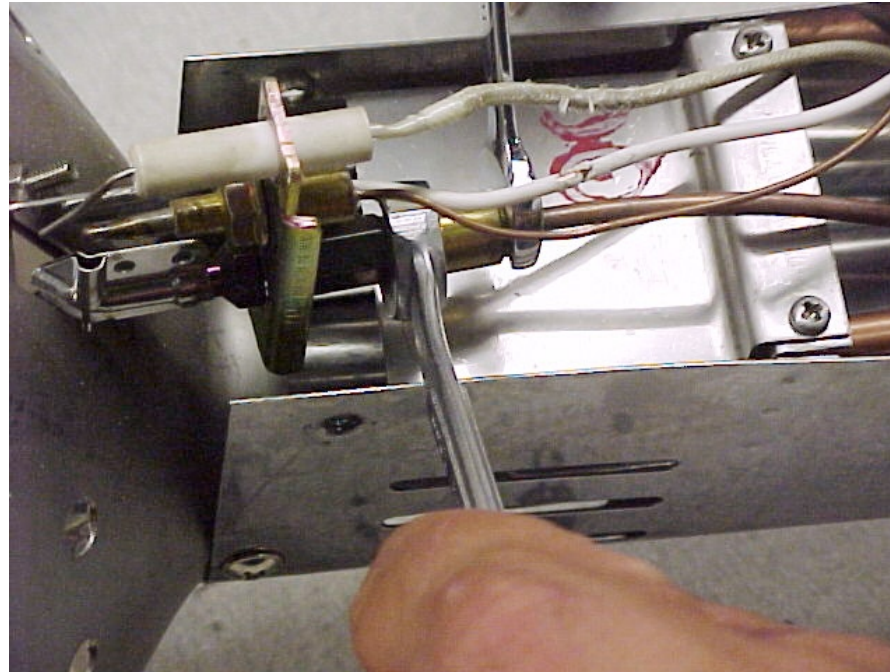

Using an open-end wrench (Size: #10mm and #12mm), remove the pilot tube.



## Step 9

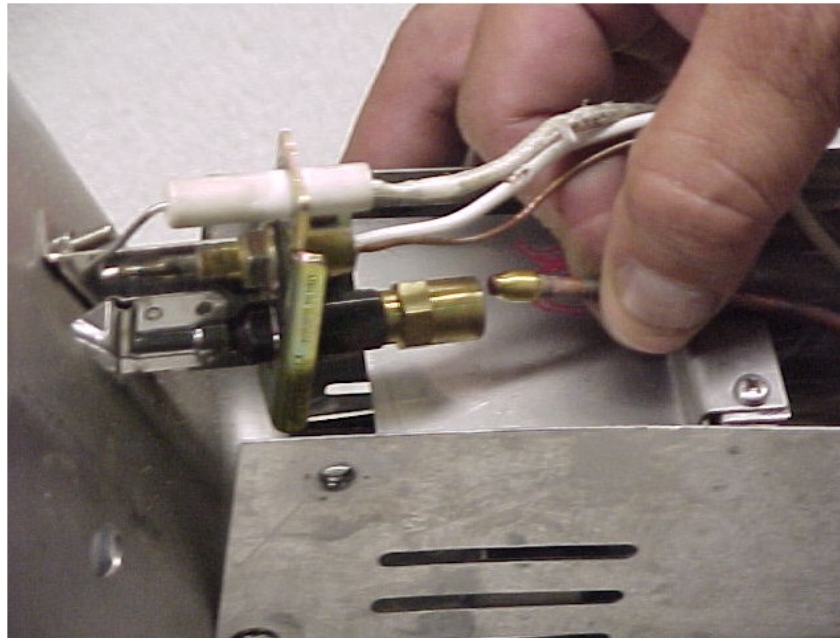

With pilot tube disconnected, remove the pilot tube.

*Note:* Use care to not kink tubing.



## Step 10

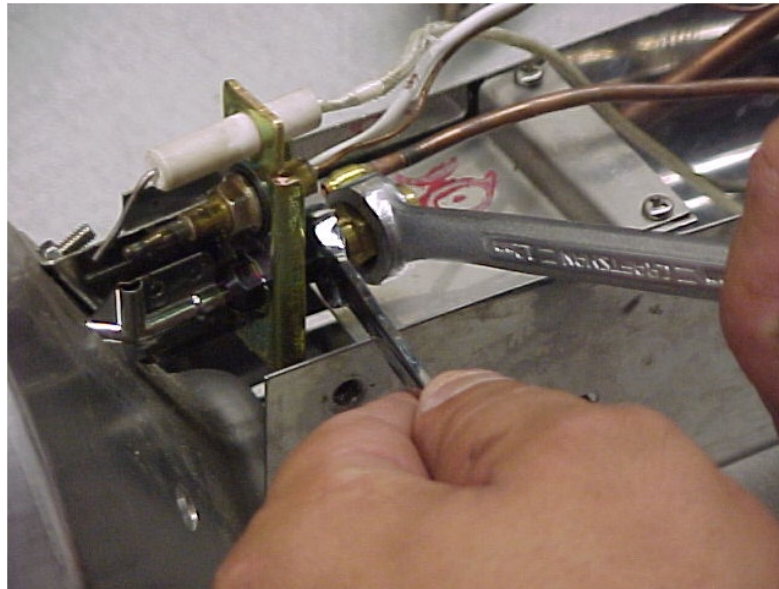

Remove the pilot orifice by using the #10mm and #12mm open-end wrenches.

*Note:* Place the #10mm wrench on the black hex tube and the #12mm wrench on the brass piece.



# Step 11

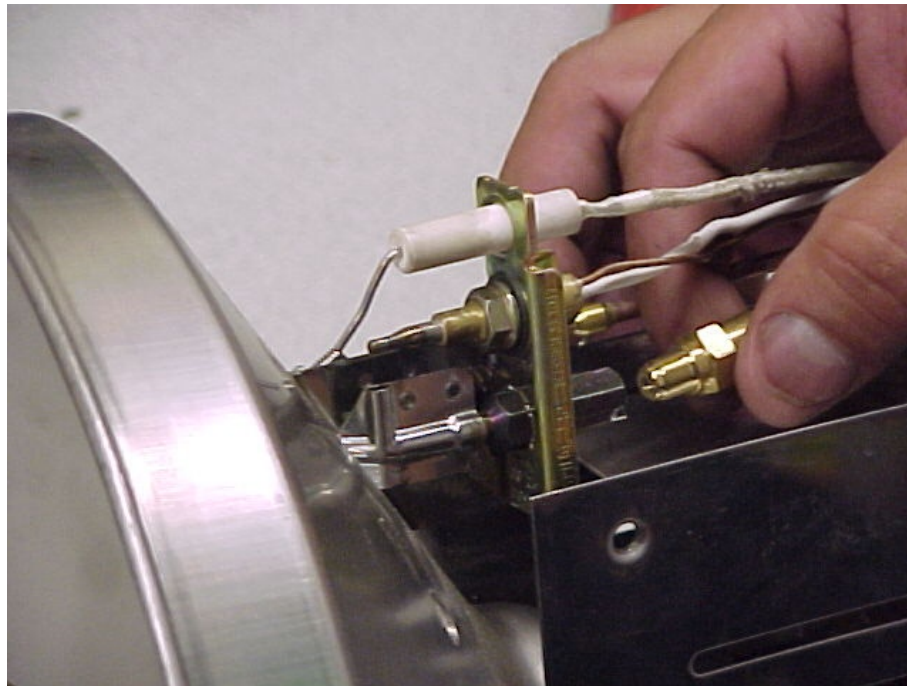

Pilot orifice is removed.



## Step 12

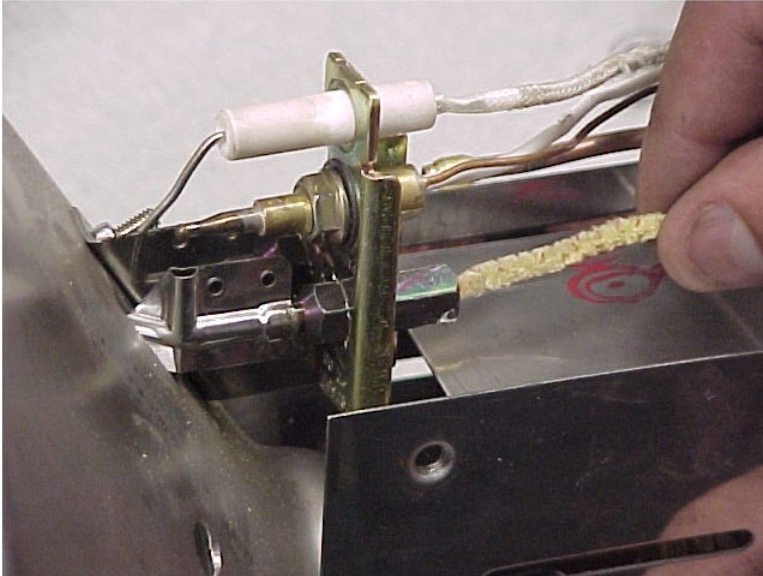

With pilot orifice removed, insert a pipe cleaner into the bottom of the pilot housing through the top of the pilot hood to clean the area.



## Step 13

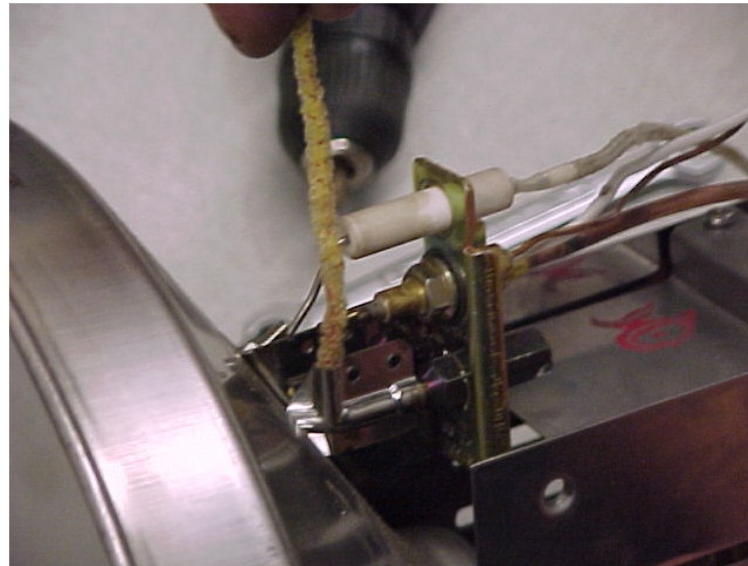

Clean both ports at the top of the pilot assembly and clean the opening at the thermal-couple.



## Step 14



Use small brush to clean the pilot orifice. Lightly brush orifice. Use care not to enlarge the orifice hole.



# Step 15

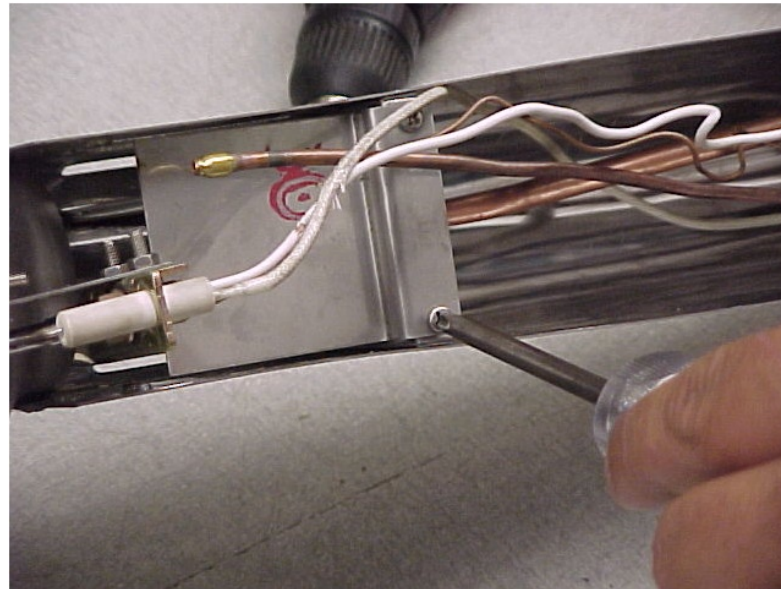

Remove the pilot heat shield to access the burner assembly.



## Step 16

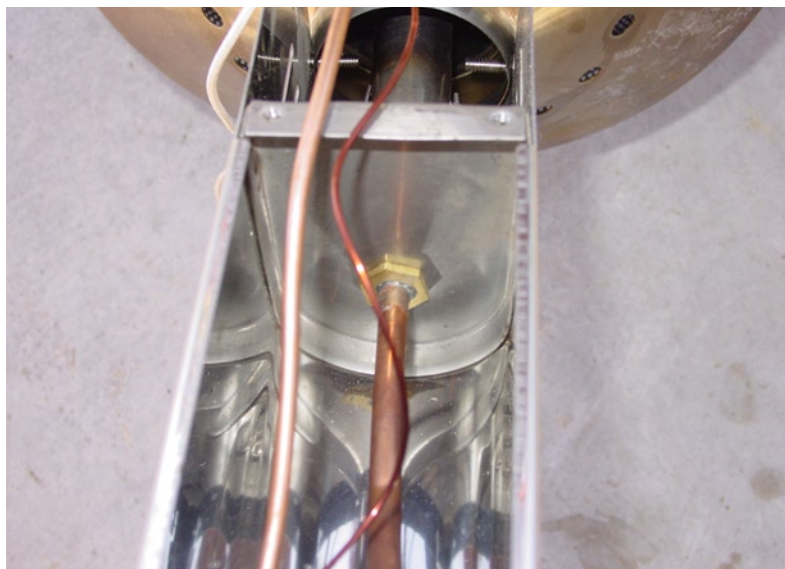

Using an 11/16" open end wrench, hold the burner supply tube nut in place to prevent it from moving. At the same time, use a 3/4" open end wrench to unscrew the burner nut from the burner.



# Step 17

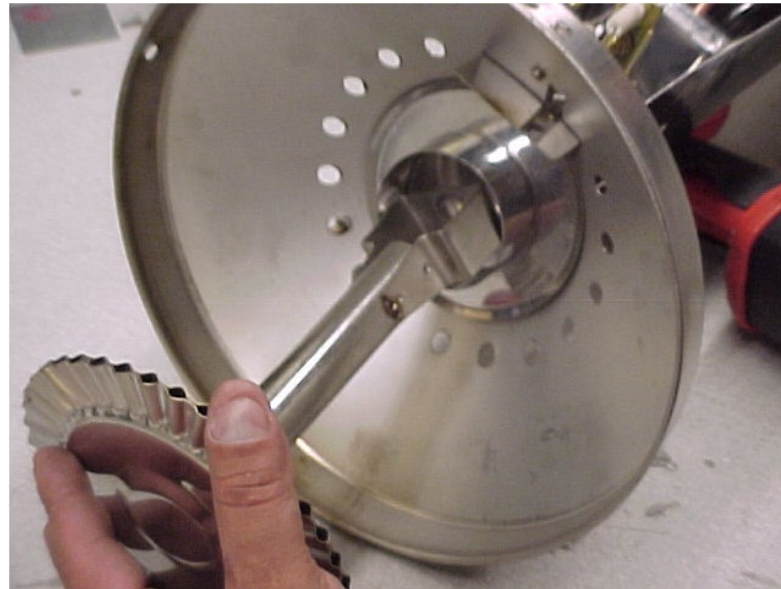

With the brass nut removed, remove burner. Be careful not to damage burner.



## Step 18



Clean venturi tube by inserting a bottle brush into the bottom of burner. Push brush in completely and twist to remove any spider webs or soot build up.



## Step 19

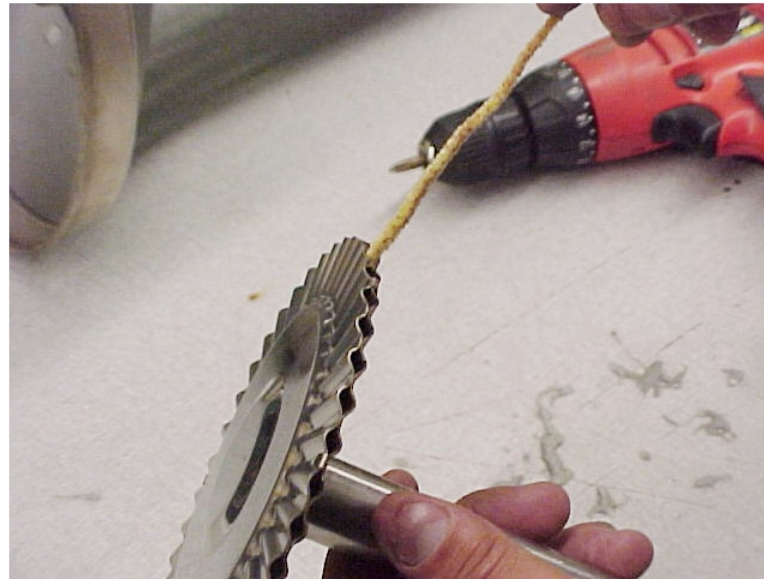

Use a pipe cleaner to clean out all burner ports.



## Step 20

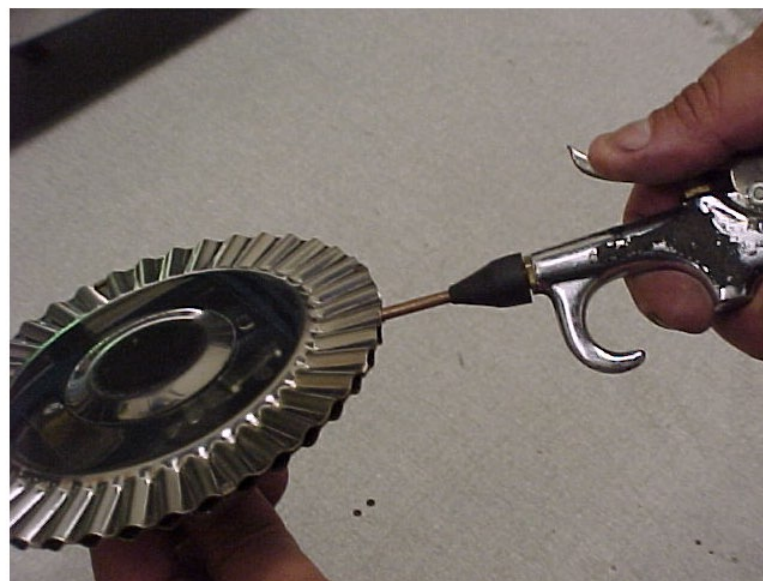

Using an air hose or a can of compressed air, blow out the venturi tube and the burner ports. This will ensure that no soot or debris is left in the burner.



## Step 21

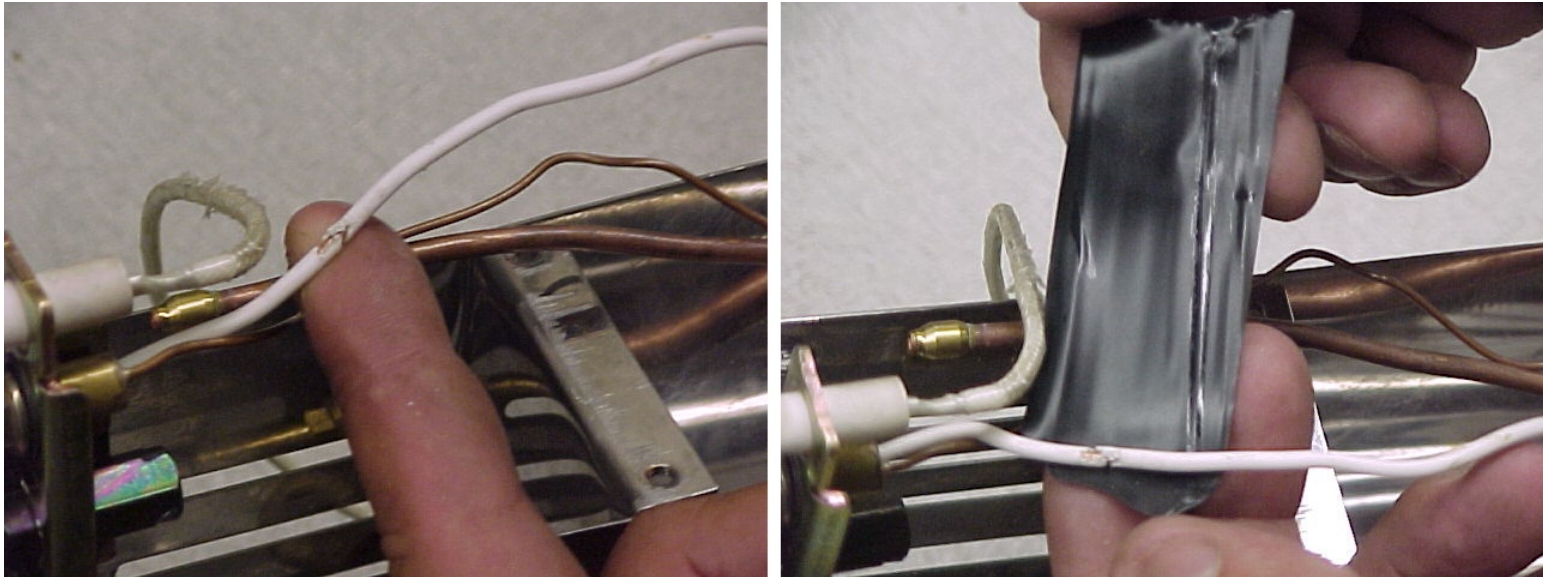

Inspect the thermal-couple wires for any wear in the insulation. Should you find exposed areas, cover with electrical tape.



## Step 22

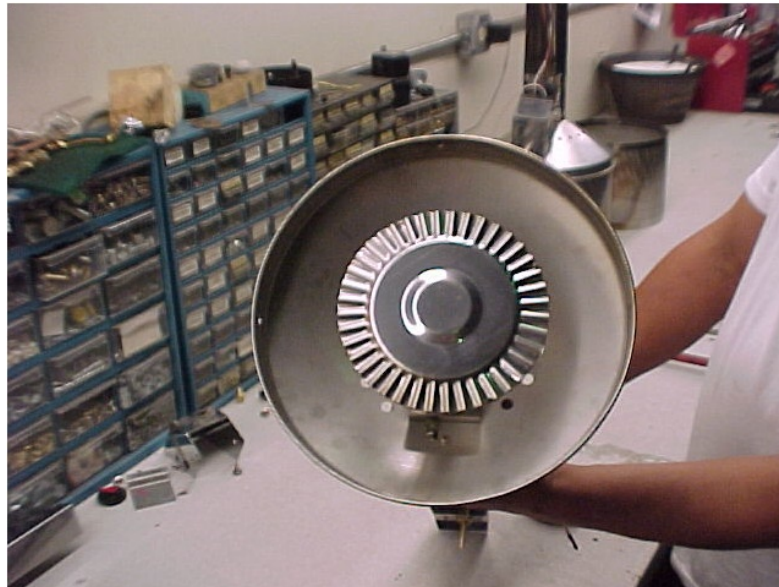

1. Reassemble the burner.
2. Make sure burner sits in the center of the emitter bottom.
3. Tighten the burner in place.
4. Reassemble the pilot heat shield.
5. Attach the pilot orifice to the pilot.
6. Attach the pilot tube to the pilot assembly.



## Steps 23-26

23. Attach the engine to the post

24. Burner Connections

1. Make sure the regulator valve and hose connections are securely fastened to the burner and the tank.
2. If your unit was assembled for you, visually check the connection between the burner pipe and orifice. Make sure the burner pipe fits over the orifice.

**WARNING: Failure to inspect this connection or follow these instructions could cause a fire or an explosion which can cause death, serious bodily injury, or damage to property.**

3. Please refer to diagram for proper installation.
4. If the burner pipe does not rest flush to the orifice, please contact 1.800.762.1142 for assistance.

25. Attach the dome

26. Attach the LP gas tank

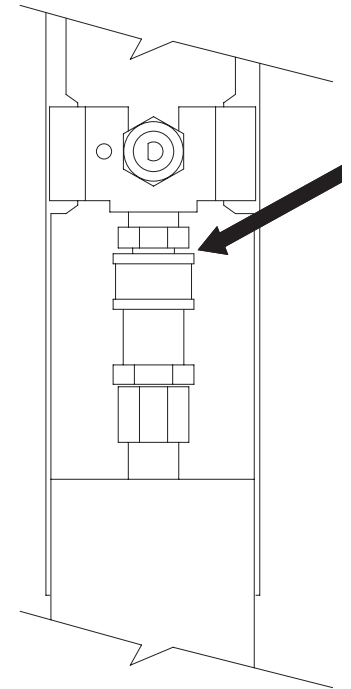

## Step 27 - IMPORTANT

Perform leak check.



### **WARNING** **FOR YOUR SAFETY**

If you smell gas -

1. Shut off gas to appliance.
2. Extinguish any open flame.
3. If odor continues, immediately call your gas supplier or your fire department.

1. Do not operate if gas leak is present. Gas leaks may cause a fire or explosion.
2. You must follow all leak-checking procedures before operating. To prevent fire or explosion hazard when testing for a leak:
  - a. Always perform leak test before lighting the heater and each time the tank is connected for use.
  - b. No smoking. Do not use or permit sources of ignition in the area while conducting a leak test.
  - c. Conduct the leak test outdoors in a well-ventilated area.
  - d. Do not use matches, lighters, or a flame to check for leaks.
  - e. Do not use heater until any and all leaks are corrected.If you are unable to stop a leak, disconnect the LP gas supply. Call a gas appliance serviceman or your local LP gas supplier.



## Tank/Gas Line Connection

1. Make 2-3 oz. of leak solution by mixing one part liquid dishwashing soap with three parts water.
2. Make sure control knobs are off.
3. Turn LP gas tank ON at valve.
4. Spoon leak check solution at all “x” locations
5. If any bubbles appear turn LP gas tank OFF, reconnect and re-test. If you continue to see bubbles after several attempts, disconnect LP gas source and contact 1.800.762.1142 for assistance.
6. If no bubbles appear after one minute turn tank OFF, wipe away solution and proceed.

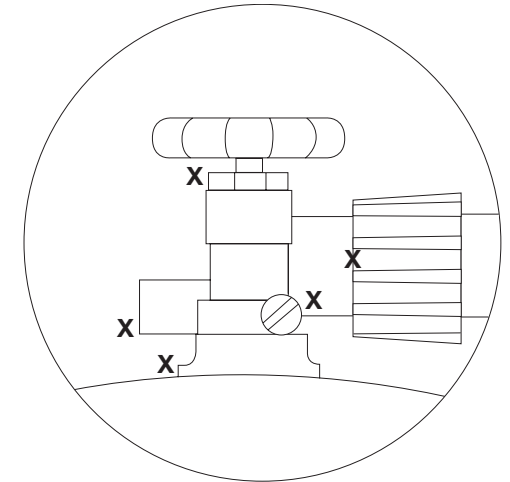

## Pilot & Pilot supply tube

1. Make 2-3 oz. of leak solution by mixing one part liquid dishwashing soap with three parts water.
2. Turn LP gas tank ON at valve.
3. Turn control knob on to LOW
4. Remove access panel
5. Place leak solution on pilot supply tube at the pilot and at the control valve.
5. If any bubbles appear turn control valve OFF, check all connection to make sure they are tight, and retest. If you continue to see bubbles after several attempts, turn control valve off and disconnect LP gas source and contact 1.800.762.1142 for assistance.
6. If no bubbles appear after one minute turn tank OFF, wipe away solution and proceed.



Blue Rhino Global Sourcing, LLC  
104 Cambridge Plaza Drive, Winston-Salem, NC 27104 USA  
1.800.762.1142, [www.bluerhino.com](http://www.bluerhino.com)

© 2004 Blue Rhino Global Sourcing, LLC All Rights Reserved.  
Endless Summer® is a registered trademark of Blue Rhino Global Sourcing, LLC All Rights Reserved.  
Blue Rhino® is a registered trademark of Ferrellgas, L.P. All Rights Reserved.