



Assembly Instructions

ONYX

Drafting Height DRAWING TABLE

Tools needed: Phillips Head Screwdriver
Awl or Drill

Parts List

- 1 Table Basepart A
- 2 Rear Extension Tubespart B
- 2 Front Extension Tubespart C
- 4 Caps for Extension Tubes.....part D
- 4 Collars.....part E
- 4 Height Adjustment Knobspart F
- 2 Metal Guide Trackspart G
- 2 Front Leg Padspart H
- 2 Rear Leg Padspart I
- 12 Phillips Head Screwspart J

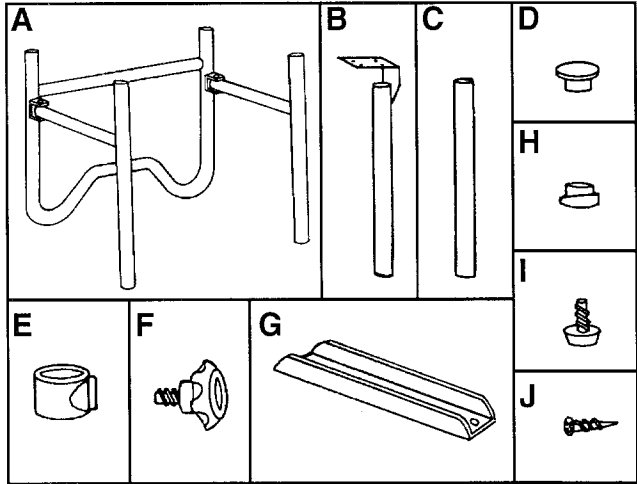

To Assemble

1. Lay out parts to be certain all are there. Note that parts "D", "H" and "I" should already be attached to the table base.
2. Open table base "A" and place the collars "E" on top of the 4 legs as shown in **Figure I**. Align the screw knobs "F" with the pre-punched holes in the legs.
3. Insert extension tubes "B" and "C" as shown in **Figure II** and tighten screw knobs "F". Begin with all 4 tubes in their lowest position for ease of assembly.
4. Choose the side of the table top you wish to use and place this side down on a soft pad or carpet on the floor.
5. Turn the assembled table base "A" upside down and place on top of the table top as shown in **Figure III**. Position the base according to the dimensions on the back side of this instruction sheet, centering it from left to right. Place metal guide tracks "G" under front legs as shown. Be sure to use the correct dimensions for the table top size you have.
6. Using a nail or drill to start screw holes, attach rear extension tube brackets "B" and metal guide tracks "G" to table top using screws "J".
7. Return table to its upright position and adjust tube extensions to the desired table top height.

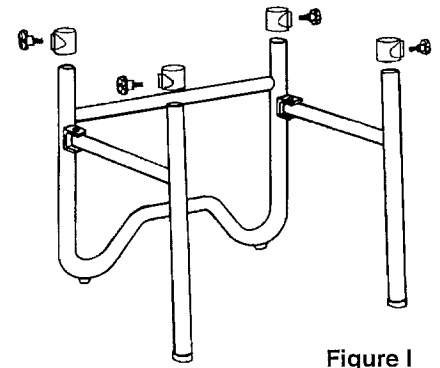

Figure I

To Fold Table Flat

1. The front height adjustment knobs "F" must be turned inward for the table to close flat. Note that these knobs will secure extension tubes whether facing inward or outward.
2. Remove front extension tubes from metal guide tracks "G" and swing legs toward back of base "A". The left leg should be folded first.
3. Allow table top to fold downward.

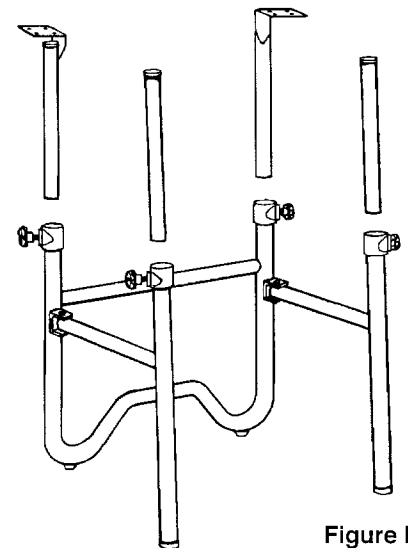

Figure II

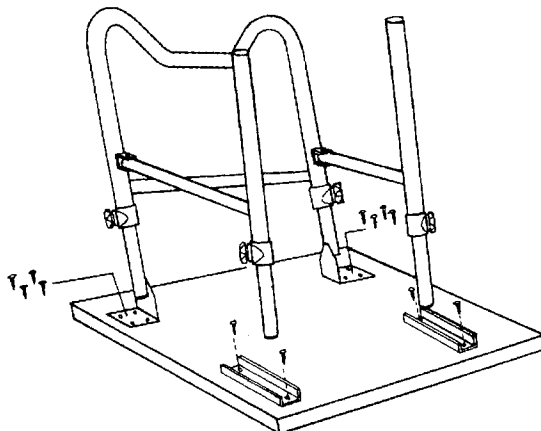
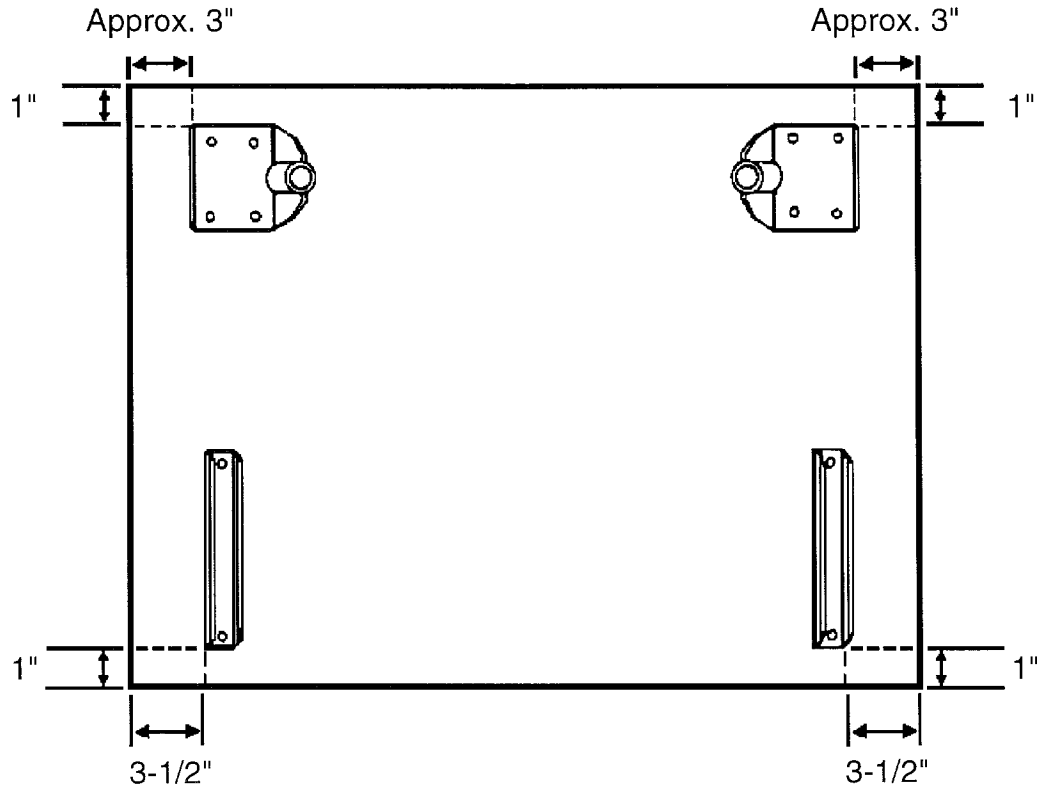

Figure III

Bracket and Track Positions for ONYX Drafting Height Drawing Table

For 24" x 36" Table Top



For 30" x 42" Table Top (CC2001 Creative Center)

