

Step 1

Insert the Gas Lift (2) into the Base (1). Place the Seat and Mechanism (3) firmly on top of the Gas Lift. Sit firmly and heavily on the chair at least three times to tighten the connecting joints.

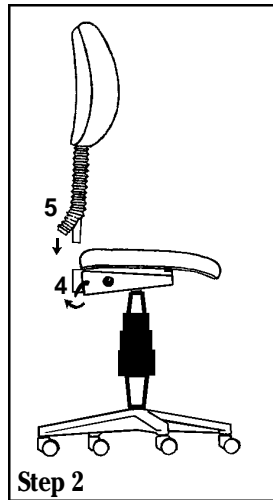

Step 2

Remove the safety pin from the back rest. Turn back control handle (4) backward and hold in place. Push back rest (5) down into the plastic square on the Mechanism.

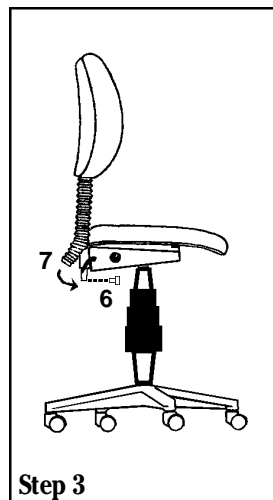

Step 3

Put safety pin into last (bottom) hole (6). Raise back up until it stops. Pull the bellow down and around the frame and over the bottom of the back rest pipe (7).

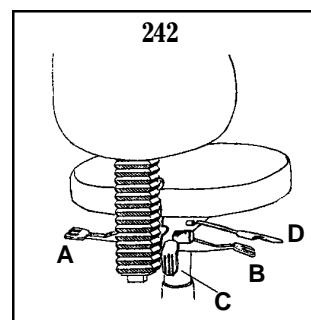
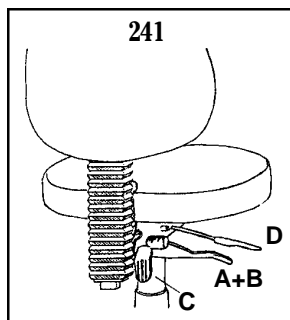

CONTENTS:

Parts	Qty
Backrest w/ safety pin	1
Seat and Mechanism	1
Gas Lift w/Cover	1
Nylon Base	1

OPERATING INSTRUCTIONS:

Before starting, please read instructions carefully.

To Lower Seat:

Lift lever D while seated; release lever when desired height is reached. Do NOT push down on lever.

To Raise Seat:

Lift lever D while taking weight off the chair; release lever when desired height is reached. Do NOT push down on lever.

To Adjust Seat Angle:

While seated, lift lever B, rock backward and/or forward until your desired seating position is reached; release lever. To "free float" the seat, push lever B all the way down until it locks; release from "free float" to lock position by returning lever B to its normal position.

To Adjust Back Angle:

While seated, lift lever A; lean backward or forward until your desired back angle position is reached, release lever. To "free float" the back, push lever A all the way down until it locks; release from "free float" to lock position by returning lever A to its normal position.

To Raise or Lower Back Support:

While seated, turn control handle C one-quarter turn backward and raise or lower the back support until the desired position is reached, release the control handle.

CAUTION: 1. Do not use this chair as a step ladder .
2. Check for loose screws and tighten them every 6 months.



"OFFICE FURNITURE MARKETING"

Assembly Instructions

Drafting Kit

DK-2

For All Chair Models

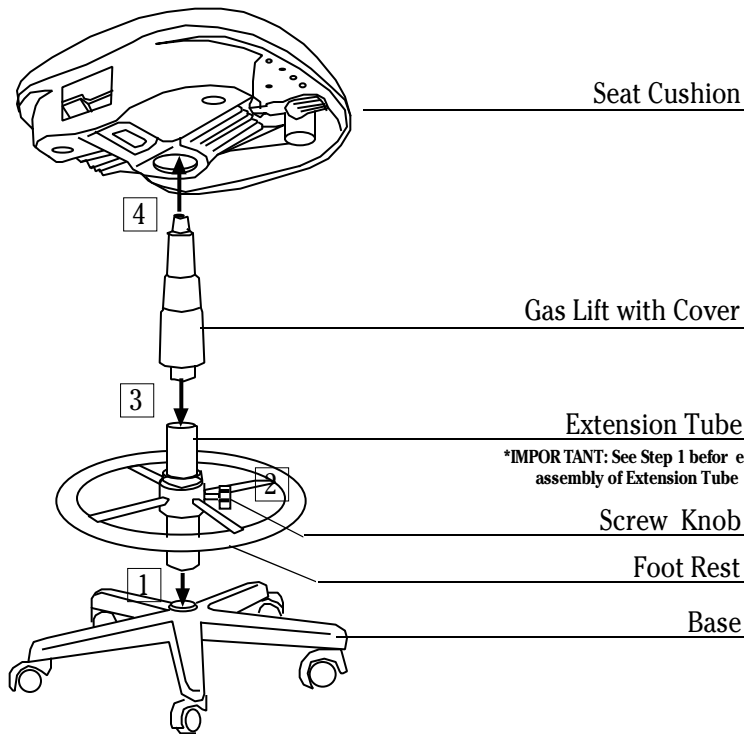

***IMPORTANT: See Step 1 before assembly of Extension Tube**

CONTENTS:

Parts	Qty	Hardware	Qty
Circular Foot Rest	1	Screw Knob	1
Extension Tube - 9"	1		
Extension Tube - 12"	1		

*See IMPORTANT note and Step A

INSTRUCTIONS:

IMPORTANT: Extension Tube selection is very important. Select only one Extension Tube size which provides the desired height prior to assembly.

*Note: 9" Extension Tube will adjust the seat height from 24"-28".

12" Extension Tube will adjust the seat height from 27"-31".

- Step A** Choose the desired Extension Tube and insert into the base (1).
- Step B** Slide the Foot Rest over the smaller tapered end of Extension Tube and tighten the Screw Knob (2).
- Step C** Insert the smaller tapered end of the Extension Tube into the base.
- Step D** Insert the bottom of the Gas Lift Cylinder into the Extension Tube opening (3). Then place the seat on top of the gas lift (4). One of the extension tubes will be left over after assembly is complete. You may save for future use or discard.

For information on these fine products call your nearest OFM furniture dealer.

- Reception Room Seating and Tables
- Ergonomic Home/Office Chairs
- Top Grain Leather Chairs
- Drafting Stools
- Steel Framed Stackable Chairs
- Office Recliners

*Polyurethane

OFM, INC.
 1003-A Investment Blvd.
 Apex, North Carolina 27502
 919.303.6389 • Fax: 919.362.4765
 Customer Service: 800.520.7471
 Technical Support: 800.520.7471
 Web Site: www.ofm.net
 E-mail: ofm@ofminc.com
 Made and printed in Taiwan.

