

CONTENTS:

Parts	Qty	Hardware	Qty
Back Cushion	1	Flat Washer (small)	4
Seat Cushion	1	Flat Washer (big)	1
Seat Plate	1	Ni-Lock Screws (6mm x 20mm)	4
Gas Lift w/ Cover	1	Wrench	1
Nylon Base	1	Seat Knob Screw (long)	1
Caster	5	Back Knob Screw (short)	1
J-Bar	1		

INSTRUCTIONS:

Before starting, please read instructions carefully.

- Step 1** Insert the 5 Casters into the outer holes on the base (1). (We recommend using a rubber hammer.) Then insert the bottom end of the Gas Lift w/Cover into the center hole on the base (2).
- Step 2** Turn the Seat Cushion upside down on a clean surface. Assemble the Seat Plate with blue threaded Ni-Lock Screws - small flat Washers provided (3)
- Step 3** Insert the J-bar into the back side of the Seat Plate(4). Tighten it with the Seat Knob & using the big flat Washer(5).
- Step 4** Place the assembled chair Seat on top of the Gas Lift (6). (Make sure the top of the Gas Lift has been properly fitted into the hole of the Seat Plate.)
- Step 5** Put the mechanism on the back side of the Back Cushion, go through the top of J-Bar, then tighten it with Back Knob Screw(7).

CAUTION: 1. Do not use this chair as a step ladder.
2. Check all screws and tighten them periodically

ASSEMBLY NOTES:

During assembly, hand tighten screws only . When all screws are in place, you may then tighten all screws completely.

CAUTION: 1. Do not use this chair as a step ladder .
2. Check for loose screws and tighten them every 6 months.

ADJUSTMENTS:

- Step A** Seat Height Adjustment: To raise the chair, lift the lever on the Seat Plate (8). To lower the seat, sit on the seat cushion and lift the lever until the seat is at the desired height.
- Step B** Seat Depth Adjustment: Loosen the Knob Screw (5) beneath the Seat Plate. Push the steel tube in to shorten the depth or pull out to lengthen the depth. Then tighten the Knob Screw again.



"OFFICE FURNITURE MARKETING"

Assembly Instructions

Adjustable Armrest

Model AA

For Chair Model 105

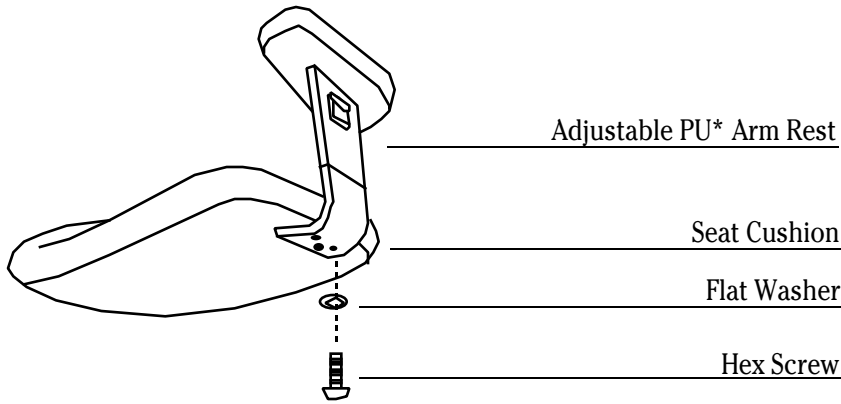

CONTENTS:

<u>Parts</u>	<u>Qty</u>	<u>Hardware</u>	<u>Qty</u>
Adjustable PU Arm Rest	1 pair	Flat Washer	6
		Hex Screw (6mm x 20mm)	6

INSTRUCTIONS:

Before starting, please read instructions carefully.

Step A Turn the Seat Cushion upside down on a clean surface. Assemble the two Adjustable PU Arm Rests with the Screws, and Flat Washers provided. (We recommend placing the larger end of the PU pad to the front.)

CAUTION: Do not suddenly apply pressure on the arm when getting up from the chair .

ADJUSTMENTS:

Arm Height Adjustment: Lift the knob on the side of the Arm Rest to adjust arm height.

For information on these fine products call your nearest OFM furniture dealer.

- Reception Room Seating and Tables
- Ergonomic Home/Office Chairs
- Top Grain Leather Chairs
- Drafting Stools
- Steel Framed Stackable Chairs
- Office Recliners

OFM,INC.
 1003-A Investment Blvd.
 Apex, North Carolina 27502
 919.303.6389 • Fax: 919.362.4765
 Customer Service: 800.520.7471
 Technical Support: 800.520.7471
 Web Site: www.ofm.net
 E-mail: ofm@ofminc.com

*Polyurethane
Made and printed in Taiwan.





"OFFICE FURNITURE MARKETING"

Assembly Instructions Drafting Kit DK-2 For All Chair Models

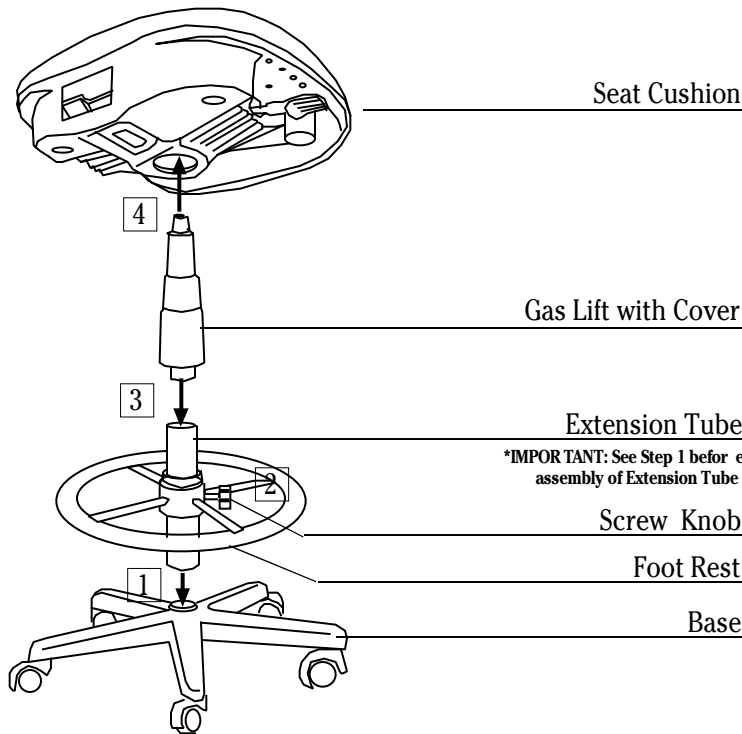

CONTENTS:

Parts	Qty	Hardware	Qty
Circular Foot Rest	1	Screw Knob	1
Extension Tube - 9"	1		
Extension Tube - 12"	1		
*See IMPORTANT note and Step A			

INSTRUCTIONS:

IMPORTANT: Extension Tube selection is very important. Select only one Extension Tube size which provides the desired height prior to assembly.

*Note: 9" Extension Tube will adjust the seat height from 24"-28".

12" Extension Tube will adjust the seat height from 27"-31".

- Step A** Choose the desired Extension Tube and insert into the base (1).
- Step B** Slide the Foot Rest over the smaller tapered end of Extension Tube and tighten the Screw Knob (2).
- Step C** Insert the smaller tapered end of the Extension Tube into the base.
- Step D** Insert the bottom of the Gas Lift Cylinder into the Extension Tube opening (3). Then place the seat on top of the gas lift (4). One of the extension tubes will be left over after assembly is complete. You may save for future use or discard.

For information on these fine products call your nearest OFM furniture dealer.

- Reception Room Seating and Tables
- Ergonomic Home/Office Chairs
- Top Grain Leather Chairs
- Drafting Stools
- Steel Framed Stackable Chairs
- Office Recliners

*Polyurethane

OFM, INC.
 1003-A Investment Blvd.
 Apex, North Carolina 27502
 919.303.6389 • Fax: 919.362.4765
 Customer Service: 800.520.7471
 Technical Support: 800.520.7471
 Web Site: www.ofm.net
 E-mail: ofm@ofminc.com
 Made and printed in Taiwan.

