



PHONE: (705) 386-0757  
 FAX: (705) 386-0915  
 TOLL FREE: 1-800-421-1406

BOX 509, SOUTH RIVER, ONTARIO P0A 1X0



## FOLDING DINING TABLE

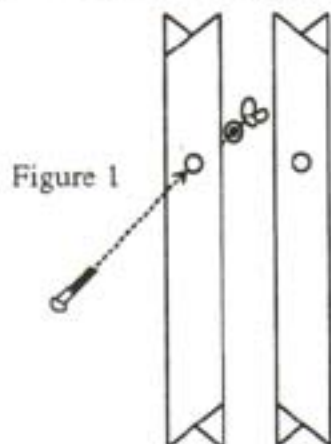

Figure 1

- 1) Take the four tables legs and make two sets as shown in figure 1. Insert carriage bolts through the holes in the legs and secure with a flat washer and wingnut. Make sure the two leg assembly are mirror images of one another as shown.

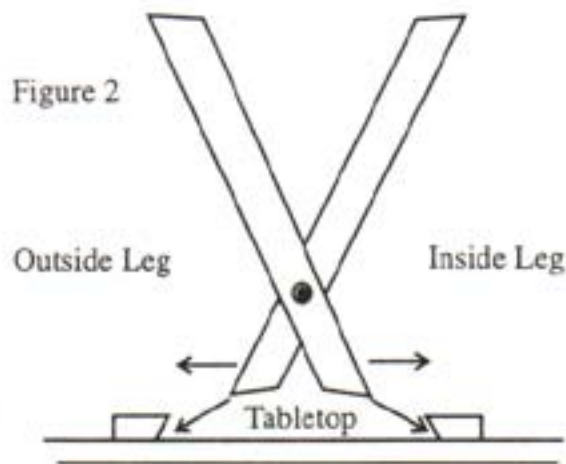

Figure 2

- 2) Turn the tabletop assembly upside down and place on a level surface. Scissor open the two sets of legs and place against the angled supports on the underside of the tabletop using one of the leg cross braces as a spacer. The two wingnuts should be facing the same direction. If not then remove one of the carriage bolts and back to step 1.

- 3) The two short cross braces are used to secure the two inside legs to each other as in figure 3. Attach the two braces, one near the bottom of the tabletop and the other about half way down the legs. Make sure that the cross braces do not stick out past the edge of the legs or it will impede the ability of the leg assembly to fold completely.

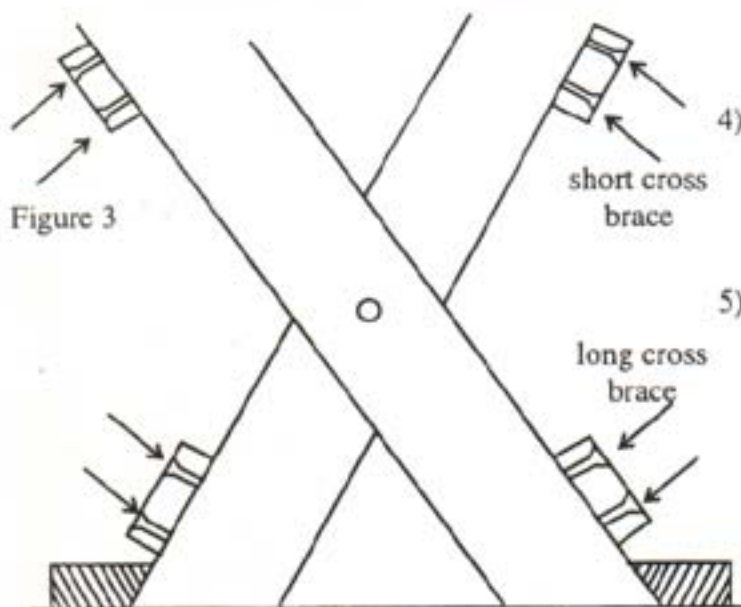

Figure 3

- 4) The two long cross braces are attached the same way as the short braces. Make sure that the braces are attached to the outside edges of the legs not the inside, or the leg assembly will not fold completely.

- 5) You are now ready to use your table. Fold your leg assembly all the way closed to make sure it doesn't bind. Open the legs about 12" and place the tabletop on the leg assembly and wiggle the top until the legs spread and engage the underside of the tabletop. Tightening the wingnuts will allow the table to be moved around as one unit and a sharp jerk will separate the two pieces to allow the legs to fold for convenient storage.



PHONE: (705) 386-0757  
 FAX: (705) 386-0915  
 TOLL FREE: 1-800-421-1406

BOX 509, SOUTH RIVER, ONTARIO P0A 1X0



## BC405P OUTDOOR DINING CHAIR

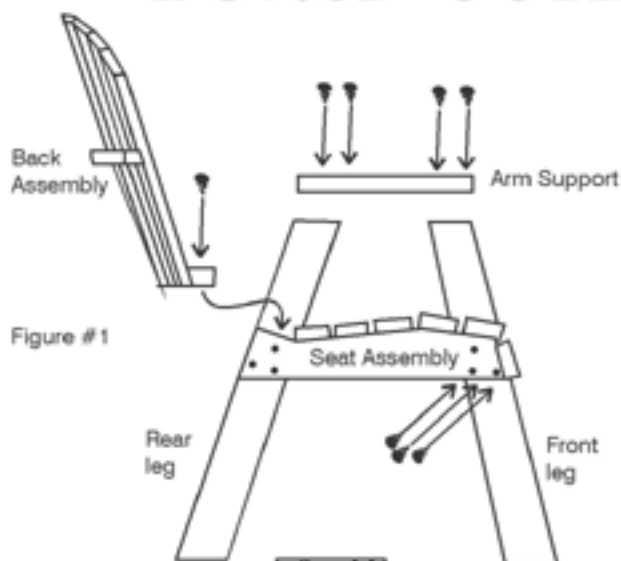

Figure #1

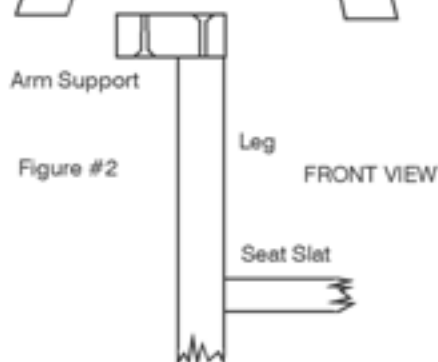

Figure #2

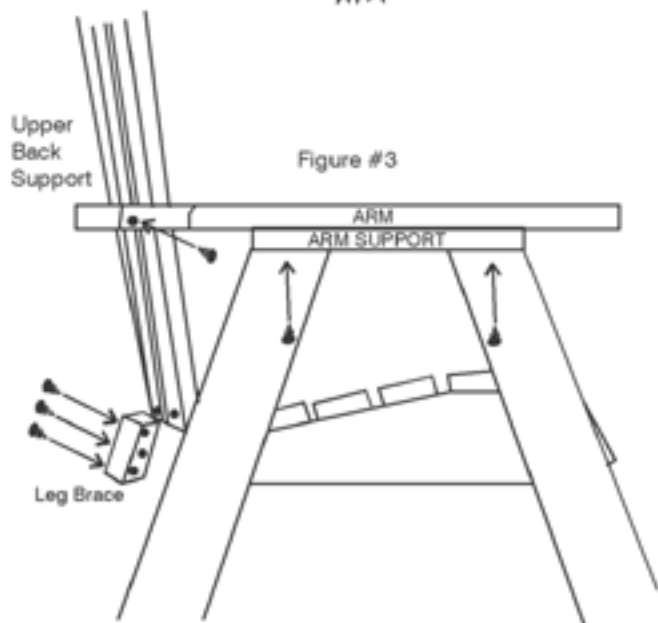

Figure #3

- 1) Attach the four legs to the corresponding pre-drilled and numbered holes in the sides of the seat assembly using 3 screws each.

Assemblez les 4 pieds avec le siège au moyen des trous numérotés et pré-percés sur les cotés du siège (utilisez 3 vis par pied).

- 2) Attach the two arm supports to the top of the legs with 2 screws in each leg as shown in diagram 2.

Fixez les 2 supports des bras sur le sommet des pieds (2 vis par pied) voir schéma #2.

- 3) Attach the back assembly to the rear edge of the seat assembly with two screws approx. 1cm. behind the last seat slat.

Assemblez le dossier pré-monté à l'arrière du siège avec 2 vis à environ 1 cm. de la dernière latte du siège.

- 4) Attach the back of the arms to the ends of the upper back support with 2 screws. (line up the back edge of the arms flush with the back edge of the back support.)

The arms should sit flat on the arm supports. They may then be attached to the arm supports with 2 screws from the underside. If the arms do not sit flat on the supports then grasp the top of the back assembly and move it forward or back with your hand until the arms sit flat and then reattach.

Assemblez les bras au dossier de chaque côté du support supérieur du dossier. Veillez à ce que l'assemblage fasse une courbe parfaite entre le bras et le support de dossier.

Les bras doivent être parfaitement plan sur leurs supports ensuite vissez les bras aux supports au moyen de 2 vis. Si les bras ne sont pas plan sur le support faites pivoter le dossier (en le tenant par le haut) jusqu'à obtenir un assemblage correcte entre le bras et son support-ensuite vissez.

5. Attach the leg brace to the back of the rear legs with 6 screws, butting it against the bottom of the back assembly.

Fixez la latte d'assemblage (au moyen de 6 vis) sur les pieds arrières. Cette latte doit butter sur le bas du dossier.

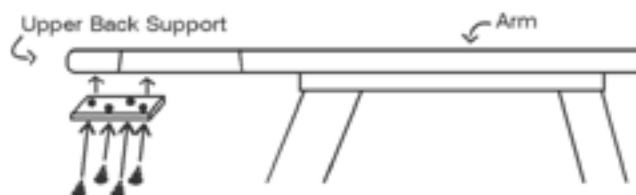

Attach the 2 plates to the joint of the arm and the upper back support with 4 screws in each, straddling the joint.