

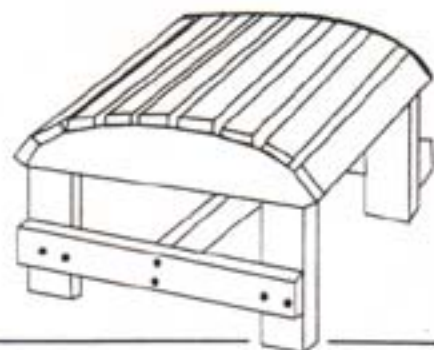

PHONE: (705) 386-0757
 FAX: (705) 386-0915
 TOLL FREE: 1-800-421-1406

BOX 509, SOUTH RIVER, ONTARIO P0A 1X0



OTTOMAN KIT BC01

Parts list/Listes des pièces

#	Description	Description des pièces	Qty.
1	Side	Côte	2
2	Legs	Pied	4
3	Slat	Planche	9
4	Support	Support	2
5	Screw	Visses	38
6	Cross Support		1

**REMEMBER TO USE
WOOD GLUE ON ALL JOINTS**

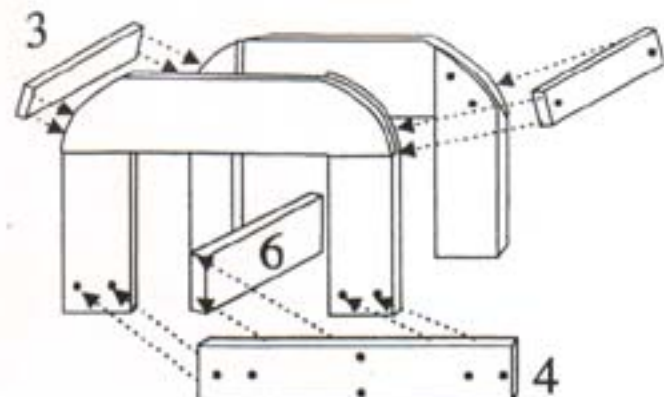
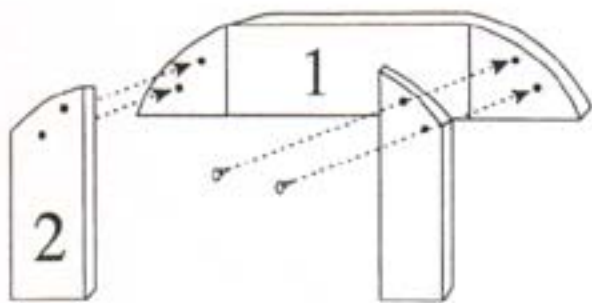

Directions

Mode d'emploi

- 1) Attach the numbered legs (#2) to the corresponding numbered side (#1) with 2 screws. (Line up the pencil marks and screw holes.)

Attacher les pieds (#2) au cote correspondant (#1) avec 2 visses. (Aligner les marques au crayon avec les trous de visses).

2. Attach the 2 sides together with a slat and 2 screws along the end of each side. (Make sure the legs are on the inside). Do the same on the other end. Dry fit the remaining 7 slats, spacing them out evenly. Do this by putting the screws through the slats so the point is just protruding out the other side, and pressing the slat into place. Attach the slats.

Attacher les 2 cotes ensemble avec une planche (#3) et deux visses le long de chaque cote. (Faire attention a avoir les pieds a l'interieur). Poser les 7 autres planches en les espacant regulierement. Faire cela en plaçant les visses a travers les planches de facon a ce que la pointe depasse de l'autre cote et en enfonçant les planches dans la partie des visses qui depasse. Verifier que tout est correct et visser les visses.

3. Place one support (#4) against two of the legs approximately 2"/50mm from the bottom of the leg and attach with 4 screws. Repeat for the other side.

Placer un support (#4) contre deux des pieds a environ 5cm du bas des pieds et l'attacher avec 4 visses. Repeter de l'autre cote.

4. Place the cross support (#6) between the two supports (#4) and attach with the remaining 4 screws.



PHONE: (705) 386-0757
 FAX: (705) 386-0915
 TOLL FREE: 1-800-421-1406

BOX 509, SOUTH RIVER, ONTARIO P0A 1X0



Folding Sidetable BC02/Petite Table Pliable BC02

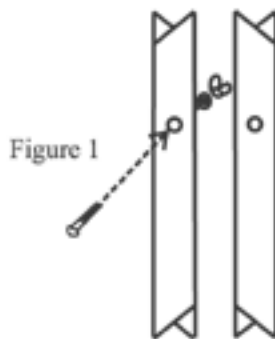

Figure 1

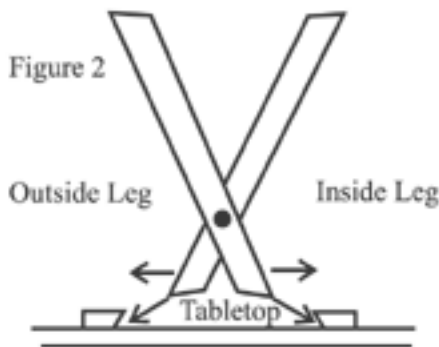

Figure 2

Outside Leg Inside Leg

Tabletop

1) Take the four tables legs and make two sets as shown in figure 1. Insert carriage bolts through the holes in the legs and secure with a flat washer and wingnut. Make sure the two leg assemblies are mirror images of one another as shown.

2) Turn the tabletop assembly upside down and place on a level surface. Scissor open the two sets of legs and place against the angled supports on the underside of the tabletop using one of the leg cross braces as a spacer. The two wingnuts should be facing inward and the inside legs of each set should be facing the same direction as in figure 5. If not then remove one of the carriage bolts and go back to step 1.

3) The two short cross braces are used to secure the two inside legs to each other as in figure 3. Attach the two braces, one near the bottom of the tabletop and the other (with the Bear Chair logo) about half way down the legs. Make sure that the cross braces do not stick out past the edge of the legs or it will impede the ability of the leg assembly to fold completely.

4) The angle brace secures the two outer legs together and is positioned as shown in figure 3 & 4. Leave a small gap (1/4") between the angled side of the brace and the inside set of legs as shown in figure 4.

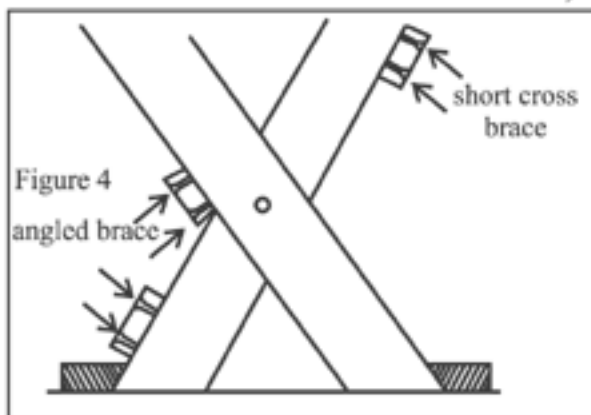

Figure 4

angled brace

short cross brace

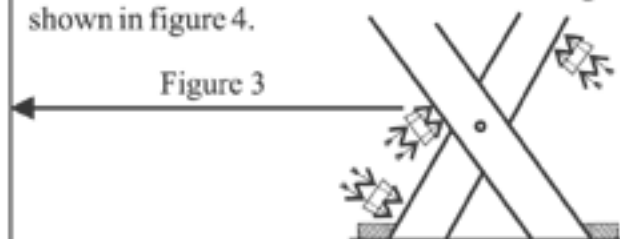
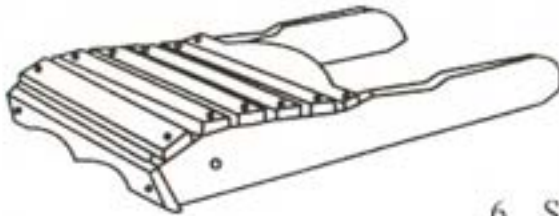

Figure 3

Figure 5



You are now ready to use your table. Fold your leg assembly all the way closed to make sure it doesn't bind. Open the legs half way and place the tabletop on the leg assembly and wiggle the top until the legs spread and engage the underside of the tabletop. Tightening the wingnuts will allow the table to be moved around as one unit and a sharp jerk will separate the two pieces to allow the legs to fold for convenient storage.



6. Space the remaining five Seat Slats (#2) evenly between the Comfort Slat (#3) and the Front Slat.

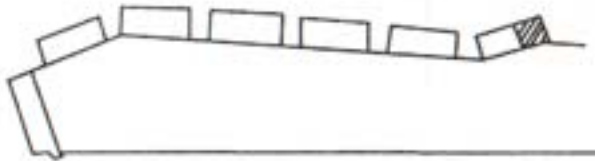

7. Attach the Legs (#5) to the seat assembly using the two 3/8 in. Carriage Bolts (#21), Washers (#22), Lockwashers (#23) and Wingnuts (#24).

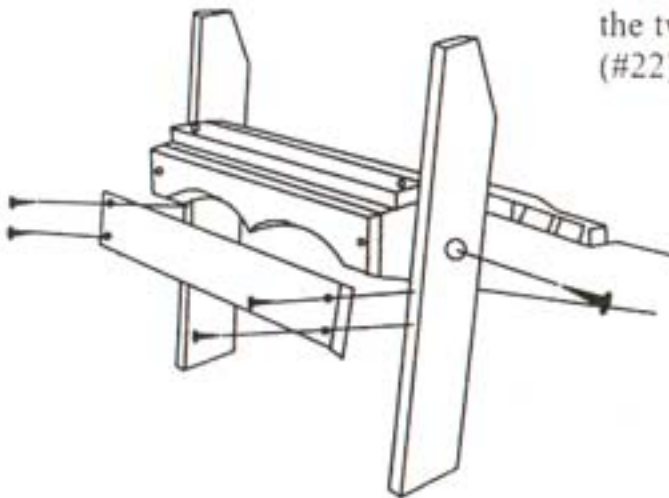

8. This next step is important so take your time to do it right. Place the seat assembly on a smooth surface (e.g. a kitchen floor) Make sure the back bottom edge of the Legs is about 1/4 in. off the ground. While pressing the leg brace firmly against the bottom of the sides attach the Leg Brace across the 2 Legs with four screws.

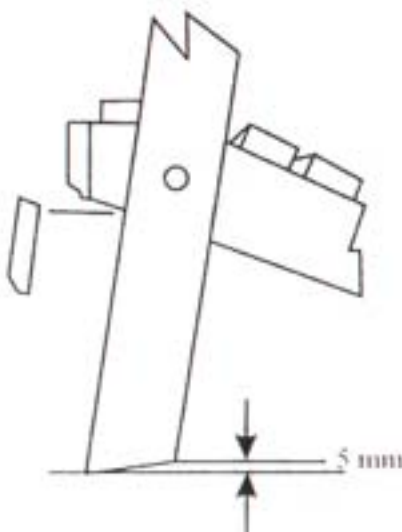

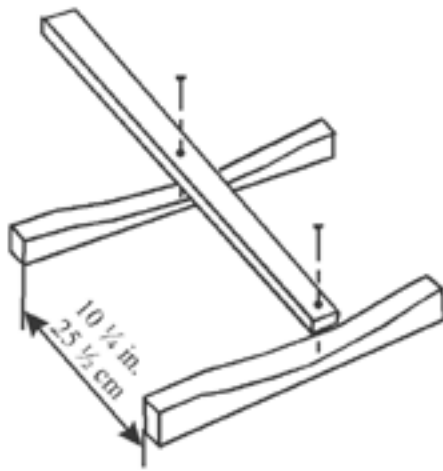

1. Arrange the Bottom and Middle Back Supports 10 $\frac{1}{4}$ in. apart and parallel. Place the longest of the seven Back Slats (#11) in the centre of the two Back Supports. It is important that it is as close to the center as possible. You may want to use a Tape Measure to make sure. Once you are sure, attach with two screws.

2. Space the remaining six Back Slats evenly and attach with two screws each. Make sure that the back does not exceed the width of a seat slat #2 (19") at its widest point.

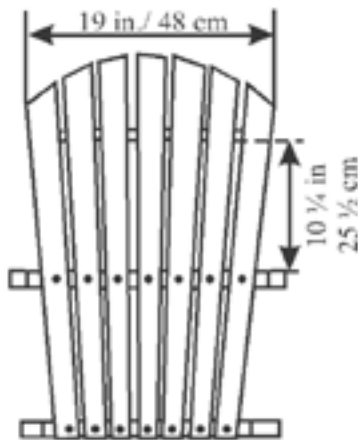

3. Attach the Upper Back Support (#10) to the back, 10 $\frac{1}{4}$ in. above the Middle Back Support, with seven screws.

4. Attach the Front Slat (#4) to the front of the two Sides (#1) using two screws.

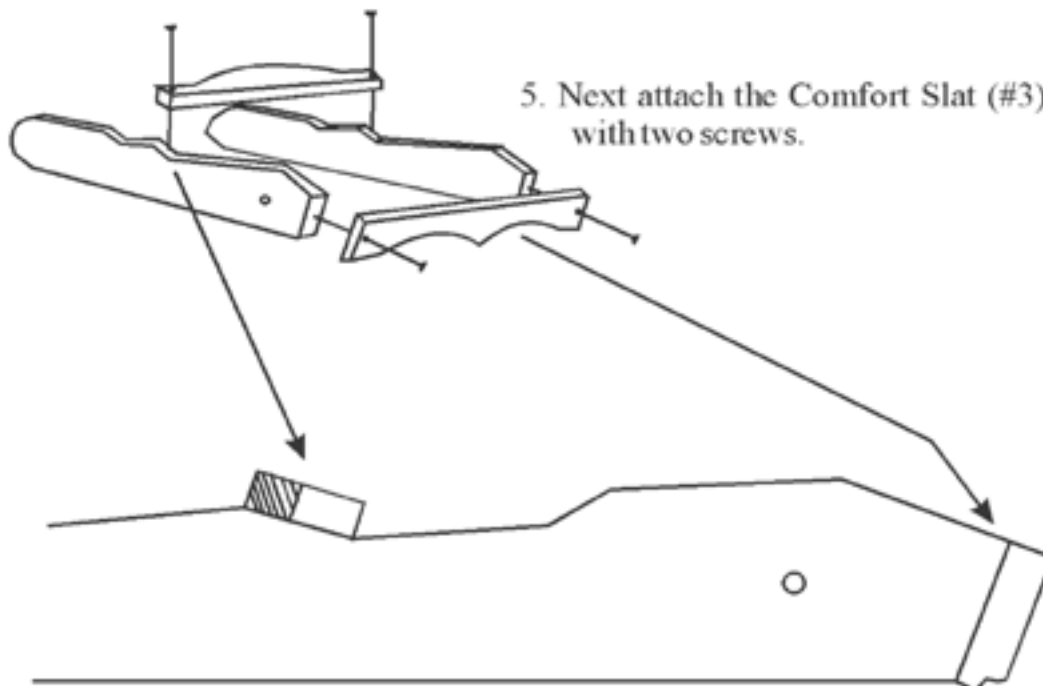

5. Next attach the Comfort Slat (#3) to the Sides with two screws.



PHONE: (705) 386-0757
 FAX: (705) 386-0915
 TOLL FREE: 1-800-421-1406

BOX 509, SOUTH RIVER, ONTARIO P0A 1X0



BC300 DELUXE FOLDING BEAR CHAIR

Pt #	DESCRIPTION	Qty.
1	Sides	2
2	Seat Slats	5
3	Comfort Slat	1
4	Front Slat	1
5	Legs	2
6	Leg Brace	1
7	Triangles	2
8	Bottom Back Support	1
9	Middle Back Support	1
10	Upper Back Support	1
11	Back Slats	7
12	Pivot Blocks	2
13	Arm Supports	2
14	Arms	2
15	#8 Plated Screws	47
16	1/4" Carriage Bolts	4
17	1/4" Washers	8
18	1/4" Lock Washers	4
19	1/4" Wing Nuts	4
20	1/4" Lag Bolts	4
21	3/8" Carriage Bolts	2
22	3/8" Washers	2
23	3/8" Lock Washers	2
24	3/8" Wing Nuts	2
25	Brass Plaque	1
26	Brass Brad Nails	2

TOOLS REQUIRED

#2 (red) Robertson Screwdriver or Screw Gun with #2 Robertson Bit, 7/16" wrench or adjustable wrench.

RECOMMENDED

Glue (Wood or Carpenters should be fine).
 100 Grit Sandpaper
 Tape Measurer



9. Attach one Pivot Block (#12) to the outside of each side with a 1/4" Carriage Bolt (16).
10. Place the back assembly between the Pivot Blocks. Line up the holes in the Pivot Blocks with the holes in the end of the Bottom Back Support, insert a 1/4" Lag Bolt (#20) and Washer (#17) in each, tighten until snug.
11. Fasten the Arm Supports (#13) to the outside of the top of the Legs with the 1/4" Carriage Bolts (#16).
12. Pull the back assembly up and insert the remaining Lag Bolts (#20) with Washers (#17), through the back holes of the Arm Supports, into the hole on each side of the Middle Back Support - Tighten until snug.

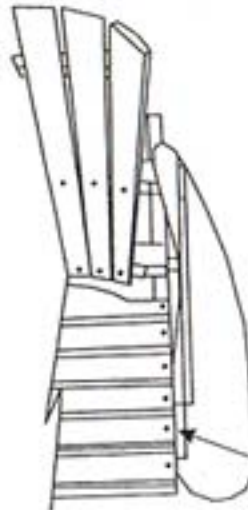

13. You are almost done. Now place the arms on the arm supports, line them up as illustrated and fasten each with 2 screws through the underside of the arm support.

* Note: Make sure the inside front part of the arm is flush with the inside of the leg.

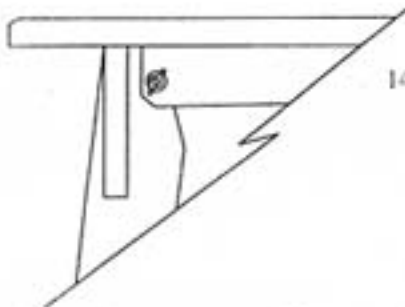

14. Finally attach the Triangles (#7) to the outside of the legs. Make sure the top of the Triangle is pressed against the bottom of the Arms and that the triangle is vertical, as seen from the side, when the chair is in its normal position. Attach with two screws each.

If there are no more parts left you must be done. Finish the chair as you prefer, attach the Brass Plaque to the middle of the Front Slat snug up all the Wingnuts and Lag bolts and enjoy!