

# **Bridgeport All Wood**

## **Assembly Instructions**

# **STOP!**

**Please read the following important information!**

For questions on assembly or parts, **DO NOT RETURN** product to the store. Contact the experts at **Elite Products** by calling **TOLL FREE.**

# **1-800-338-8667**

**Monday-Friday 8am-5pm (Pacific Standard Time)**

**elite**  
CONVERTIBLES™

By Elite Products

(Please keep this for future reference)

## Arms and Stretchers Assembly.

### Step 2 - 6

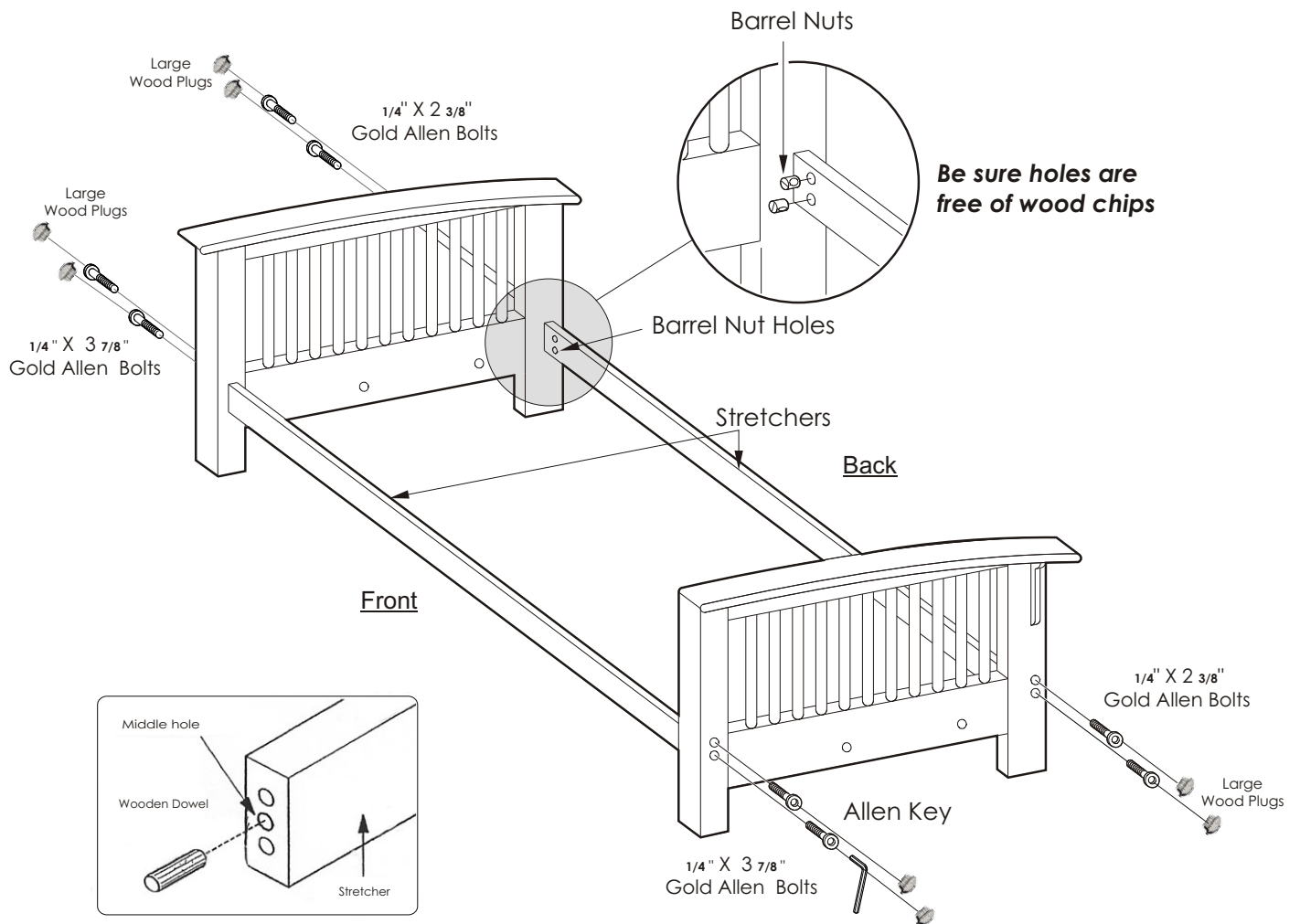

Please read all the instructions prior to assembly.

1. Attach stretcher bars to the arms using (2 Qty.) Gold Allen bolts & Barrel nuts and 1 Wooden dowel for each corner.
2. The stretcher bar holes should face towards inside of the frame.
3. Insert and tap (1Qty.) Wooden Dowel into the center of each stretcher bars, located on the ends.
4. Insert the barrel nuts into the holes with the screwdriver slots facing out.
5. Slide 1/4" x 3 7/8" Gold Allen bolts through holes in front legs of the arms and screw into barrel nuts.
6. Slide 1/4" x 2 3/8" Gold Allen bolts through holes in back legs of the arms and screw into barrel nuts.

**Note: Overhang on arm top should be facing outward**

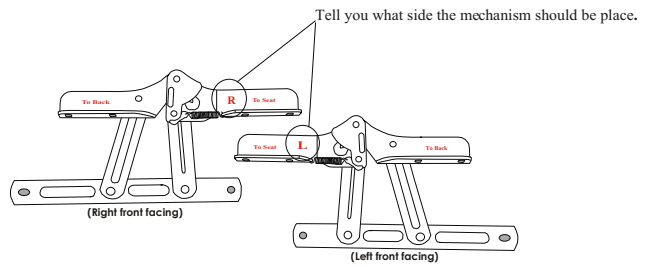
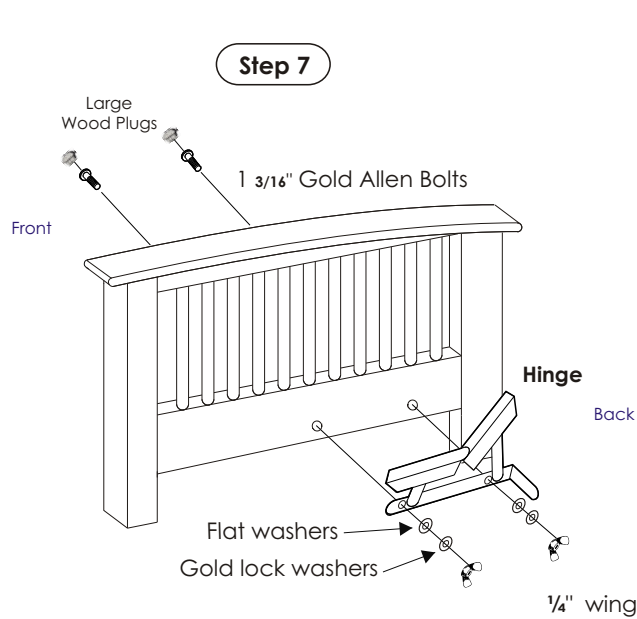

- Secure hinges to arms using (2) 1 3/16" Gold allen bolts, (2 qty.) flat washers, (2 qty.) gold lock washers, and (2qty.) wing nuts on each arm. Position the hinges (using the holes in the arms) more towards the back of the frame. **Completely tighten all hinge hardware.**
- Install wood seat to hinge, using 3 1/4" Gold allen bolts, flat washers, gold lock washers and wing nuts for each side. Repeat process for wood back installation. **Completely tighten all hardware.** After tightening hardware insert and tap (6 qty.) large wood plugs in holes of each arm.

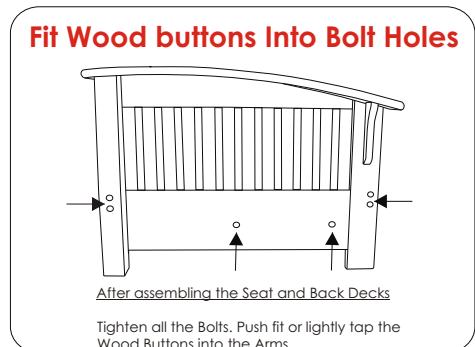
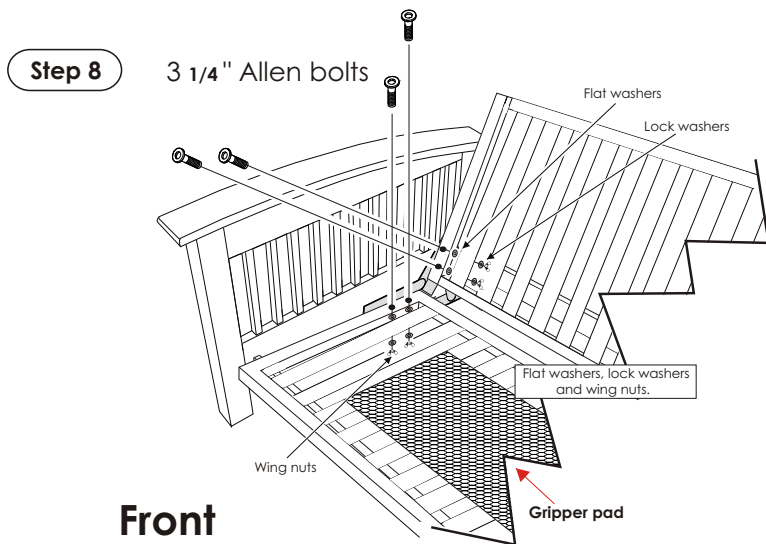

Your futon is now assembled; Gripper, place gripper on wood seat prior to putting mattress in place.

**IMPORTANT!!!**

Always operate sofa sleeper mechanism from front center of seat. See page 5 Operating Instructions

# Bridgeport Assembly Instructions

For questions on assembly or parts, **DO NOT RETURN** this product to the store. Contact the experts at Elite Products by calling **TOLL FREE 1-800-338-8667**

## Parts List *Wood Components and Hardware*

Please check parts list for correct hardware count. If the futon arms came in a separate box some hardware may be packed inside. The quantities listed are the minimum required, **you may receive extra hardware.**

### Arms and Stretcher Bar Hardware:



Allen Key x 1 piece



1/4" x 3 7/8" Gold Allen Bolts x 4 pieces



1/4" x 2 3/8" Gold Allen Bolts x 4 pieces



1/4" x 1 3/16" Gold Allen Bolts x 4 pieces



Flat Washers x 4 pieces



Gold Lock Washers x 4 pieces



Barrel Nuts x 8 pieces



1/4" Gold Wing Nuts x 4 pieces



Wood Buttons Large 5/8" x 12 pieces



Wood Dowels x 4 pieces

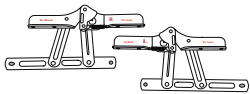

Click, Click Hinge (1 left, 1 right)

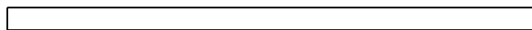

76 1/4" Stretcher Bars x 2 pieces

### Seat and back Hardware:



Wood Seat x1 piece



Wood Back x1 piece



3 1/4" Gold Allen Bolts x 8 pieces



Flat Washers x 8 pieces



1/4" Gold Wing Nuts x 8 pieces

Arms x 2 pieces

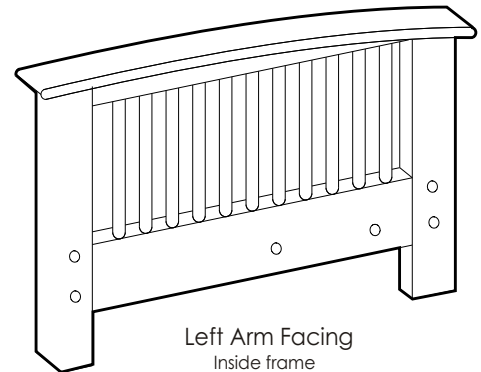

Left Arm Facing  
Inside frame

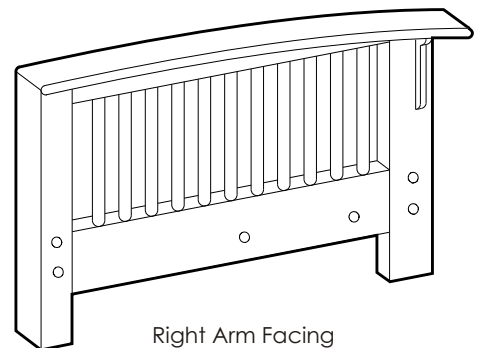

Right Arm Facing  
Outside Frame

# IMPORTANT!! IMPORTANT!!

## Do Not Operate Click- Click Hinges Until You Read These Simple Operations!!

### Step #1 Bed to lounger position.

Pull up gently on the **center** of the seat to the point. (Approx.120 degrees) where the hinges click on both sides. **IMPORTANT!** You must hear the hinges click on both sides. Then bring (push down) the seat down across the front stretcher bar. Now, the futon is in lounger position.

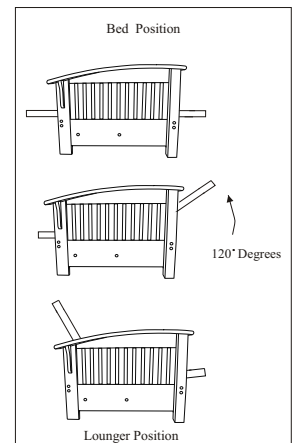

### Step #2 Lounger to sofa position.

Pull up gently on the **center** of the seat to the point (approx.90degrees) until you hear a single click on both hinges. **IMPORTANT!** You must hear the hinges click on both sides. Then bring (push down) the seat down across the front stretcher. Now, the futon is in sofa position.

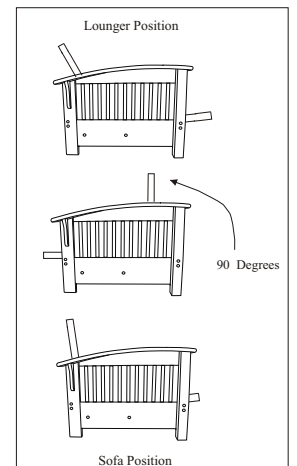

### Step #3 Sofa to bed position.

Pull up gently on the **center** of the seat to a point (approx.75 degrees) until you hear a single click on both hinges. **IMPORTANT!** You must hear the hinges click on both sides. Then bring (push down) the seat down across the front stretcher bar. Now the futon is in bed position.

