

Mead All Wood

Assembly Instructions

STOP!

Please read the following important information!

For questions on assembly or parts, **DO NOT RETURN** product to the store. Contact the experts at Elite Products by calling **TOLL FREE.**

1-800-338-8667

Monday-Friday 8am-4pm (Pacific Standard Time)

elite
CONVERTIBLES™

By Elite Products

(Please keep this for future reference)

Arms and Stretcher Assembly.

1. Please read all the instructions prior to assembly.
2. Attach stretcher bars to the arms using (2) $\frac{1}{4}$ " x $4 \frac{3}{4}$ " Black Allen bolts and barrel nuts for each corner.
3. Holes for the barrel nuts (on stretcher bars) should face towards inside of the frame.
4. Insert the barrel nuts into the holes with the screwdriver slots facing out.
5. Slide $\frac{1}{4}$ " x $4 \frac{3}{4}$ " allen bolts through holes in front legs of the arms and screw into barrel nuts.

Note: Overhang on Arm Top must be facing outward

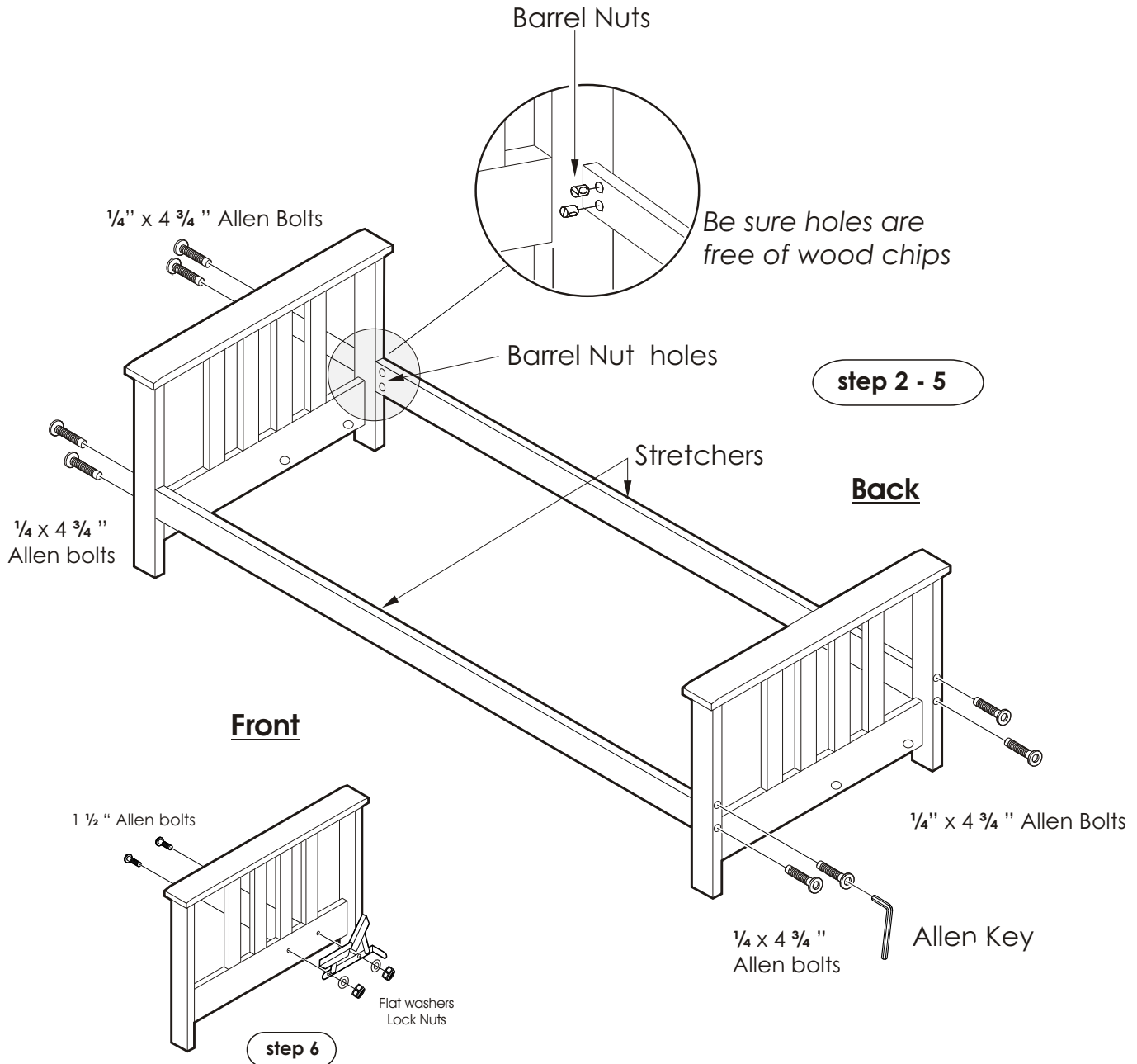

6. Secure hinges to arms using $1 \frac{1}{2}$ " allen bolts, flat washer, and lock nuts. Position the hinges (using the holes in the arms) more towards the rear of the frame. **Tighten all hinge hardware.**

Assemble Hinge, Seat, and Deck.

7. Install wood seat to hinge, using 3 1/2 " allen bolts, flat washers, and lock nuts. Repeat process for wood back installation. **Note: Lock nuts are nylon locking and will require wrench & allen key to tighten completely. Now Completely tighten all hardware.**

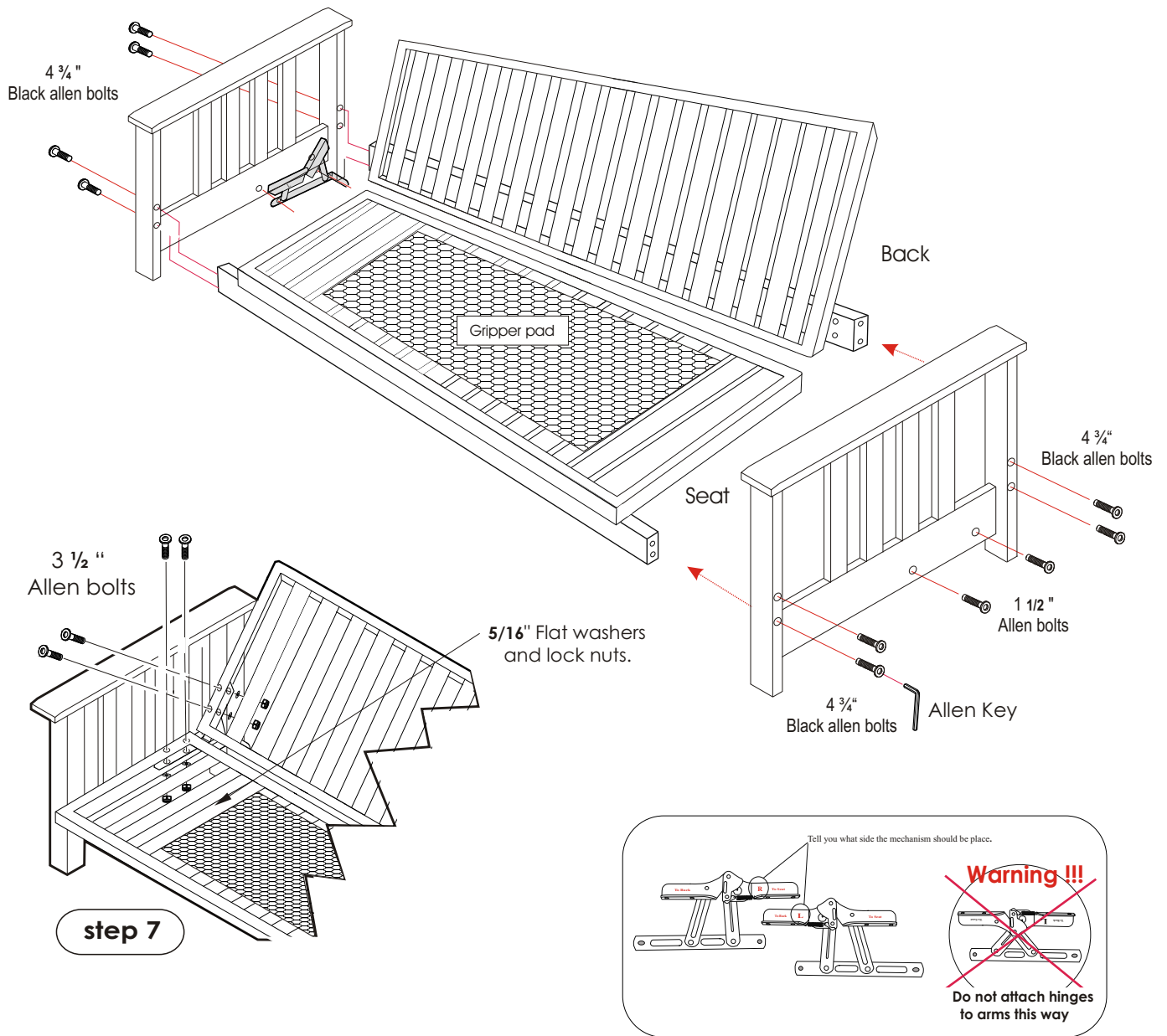

Your futon is now assembled; check all nuts and bolts, make sure they are all tight.

If fabric gripper came with your futon, place gripper on wood seat prior to putting mattress in place.

To convert your futon frame from sitting position to bed position, lift up on wood seat and pull towards you.

To convert from bed position back to sitting position, stand beside frame, hold down on frame arm and pull up on wood back; or stand in front of frame, lift up on seat and push seat away from you (towards back).

Assembly Instructions Sheet

For questions on assembly or parts, **DO NOT RETURN** this product to the store.
 Contact experts at Elite Products by calling **TOLL FREE 1-800-338-8667**

Parts List Wood Components and Hardware

Please check parts list for correct hardware count. If the futon arms came in a separate box some hardware may be packed inside. The quantities listed are the minimum required, **you may receive extra hardware.**



1/4" Small Allen Key x 1 pieces

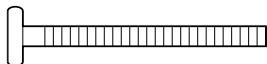

1/4" x 4 3/4" Barrel Bolts x 8 pieces



1/4" x 1 1/2" Allen Bolts x 4 pieces



Flat Washers x 4 pieces



1/4" Lock Nuts x 4 pieces

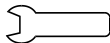

1/4" Wrench x 2 pieces



Barrel Nuts x 8 pieces

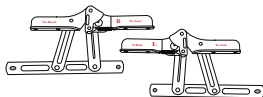

Click, Click Hinge (1 left, 1 right)

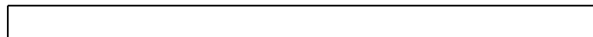

76" Stretcher Bars x 2 pieces

Arms x 2 pieces

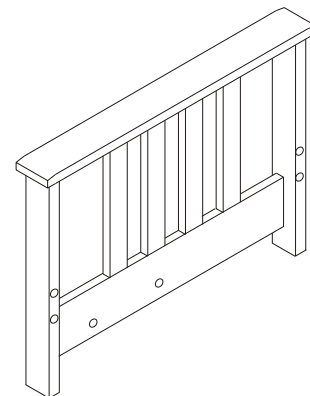

Left Arm Facing

Wood Components and Hardware



Wood Seat x1 piece



Wood Back x1 piece



1/4" x 3 1/2" Black Allen Bolts x 8 pieces



Flat Washers x 8 pieces



1/4" Lock Nuts x 8 pieces

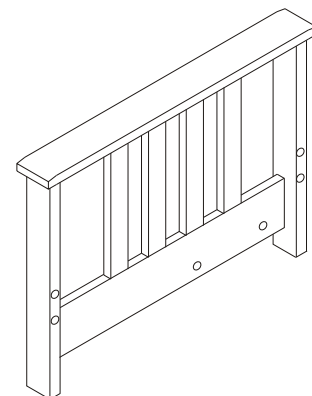

Right Arm Facing

IMPORTANT!! IMPORTANT!!

Do Not Operate Click- Click Hinges Until You Read These Simple Operations!!

Step #1 Bed to lounger position.

Pull up gently on the **center** of the seat to the point. (Approx. 120 degrees) where the hinges click on both sides. **IMPORTANT!** You must hear the hinges click on both sides. Then bring (push down) the seat down across the front stretcher bar. Now, the futon is in lounger position.

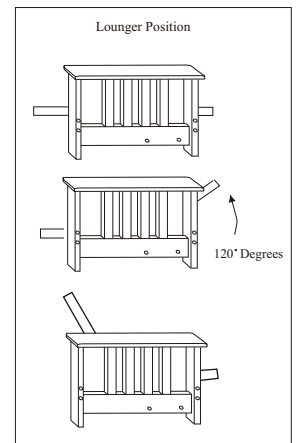

Step #2 Lounger to sofa position.

Pull up gently on the **center** of the seat to the point (approx. 90 degrees) until you hear a single click on both hinges. **IMPORTANT!** You must hear the hinges click on both sides. Then bring (push down) the seat down across the front stretcher. Now, the futon is in sofa position.

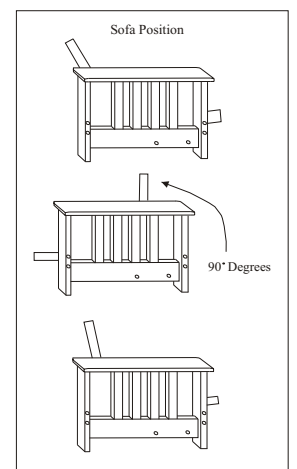

Step #3 Sofa to bed position.

Pull up gently on the **center** of the seat to a point (approx. 75 degrees) until you hear a single click on both hinges. **IMPORTANT!** You must hear the hinges click on both sides. Then bring (push down) the seat down across the front stretcher bar. Now the futon is in bed position.

