

Salsa All Wood Assembly Instructions

STOP!

Please read the following important information!

For questions on assembly or parts, DO NOT RETURN product to the store. Contact the experts at Elite Products by calling TOLL FREE.

1-800-338-8667

elite[™]
CONVERTIBLES

By Elite Products

(Please keep this for future reference)

Salsa Assembly Instruction Sheet

1. Please read all the instructions prior to assembly.
2. Attach stretcher bars to the arms using (2) 1/4" x 4" barrel bolts and nuts for each corner.
3. Holes for the barrel nuts (on stretcher bars) should face towards inside of the frame.
4. Insert the barrel nuts into the holes with the screwdriver slots facing out
5. Slide 1/4" x 4" barrel bolts through holes in front and back legs of the arms and screw into barrel nuts.

Note: Overhang on Arm Top must be facing outward

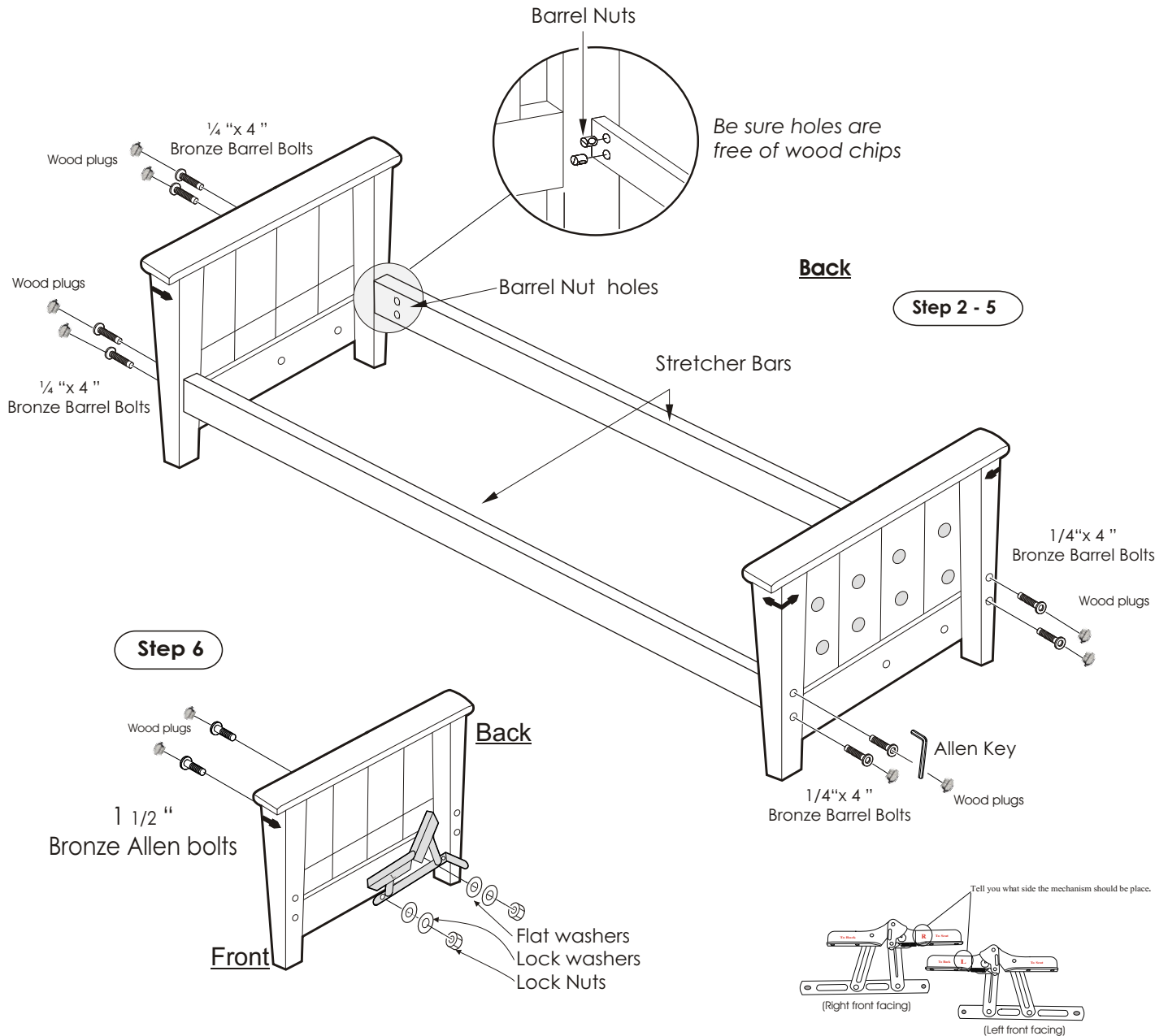

6. Secure hinges to arms using 1 1/2" bronze allen bolts, flat washers, lock washers and lock nuts. Position the hinges (using the holes in the arms) more towards the rear of the frame. **Important: Completely tighten hinges hardware to arms.**



7. Install wood seat to hinge, using 3 1/2 " black allen bolts, flat washers, and lock nuts. Repeat process for wood back installation. **Completely tighten all hardware.** Insert and tap (6 qty.) wood plugs in holes of each arms.
Note: Lock nuts are nylon locking and will require wrench & allen key to tighten completely.

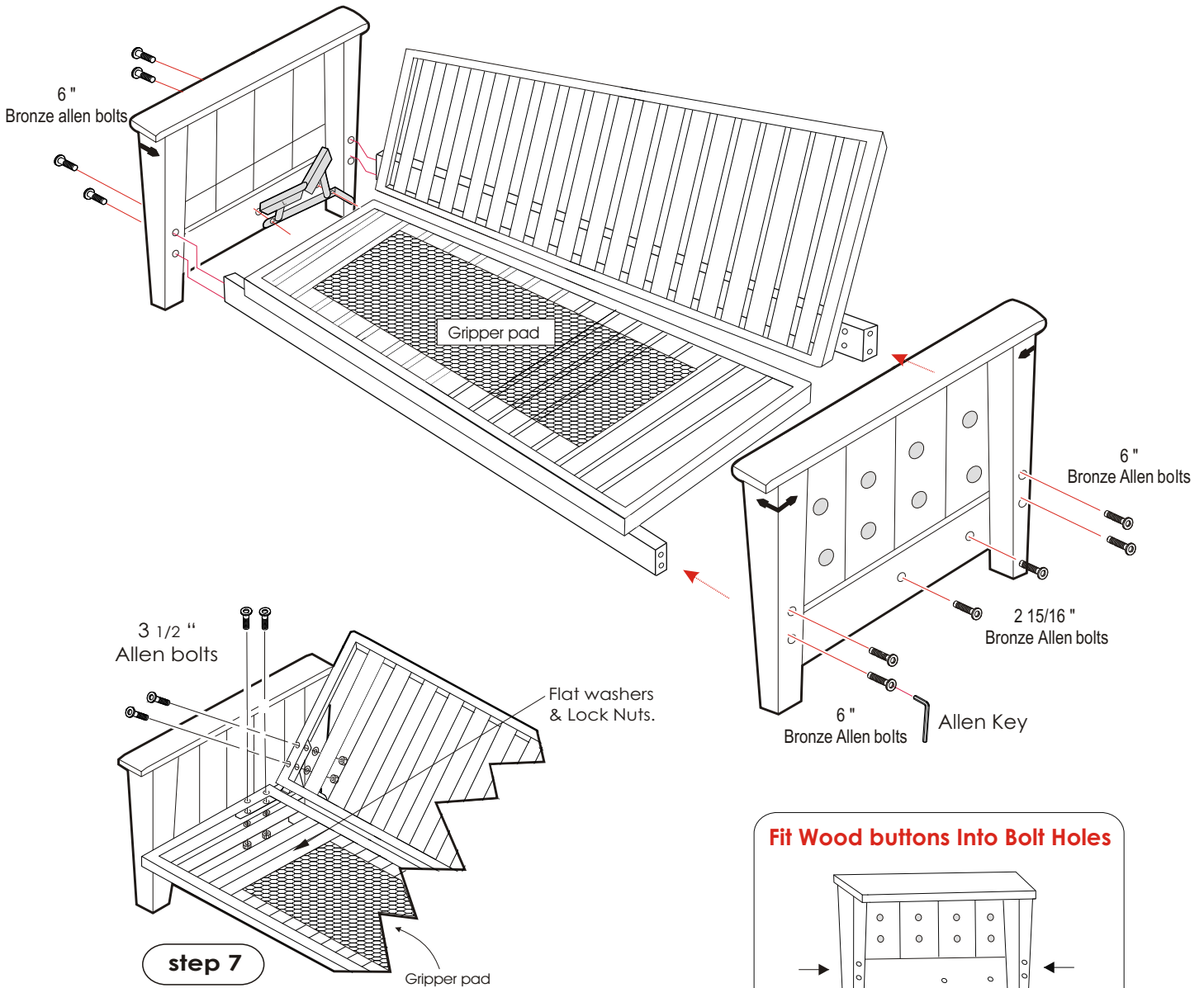

Fit Wood buttons Into Bolt Holes

After assembling the Seat and Back Decks
 Tighten all the Bolts. Push fit or lightly tap the Wood Buttons into the Arms.

Your futon is now assembled; Gripper, place gripper on wood seat prior to putting mattress in place.

IMPORTANT!!!

Always operate sofa sleeper mechanism from front center of seat. See page 5 Operating Instructions









Salsa Assembly Instructions Sheet

For questions on assembly or parts, **DO NOT RETURN** this product to the store.
Contact experts at Elite Products by calling **TOLL FREE 1-800-338-8667**

Parts List

Please check parts list for correct hardware count. If the futon arms came in a separate box some hardware may be packed inside. The quantities listed are the minimum required, **you may receive extra hardware.**

Wood Components and Hardware

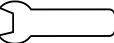
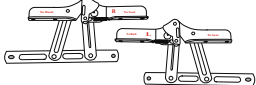
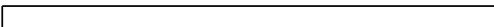

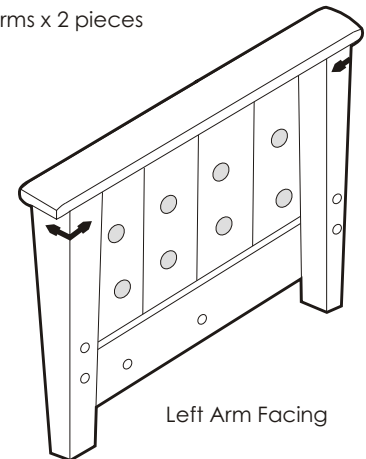

-  Allen Key x 1 piece 1/4"
-  1/4" x 4" Bronze Barrel Bolts x 8 pieces
-  1/4" x 1 1/2" Bronze Barrel Bolts x 4 pieces
-  Barrel Nuts x 8 pieces
-  1/4" Lock Nuts x 4 pieces
-  1/4" Flat Washers x 4 pieces
-  Lock Washers x 4 pieces
-  Wood Buttons Large x 12 pieces
-  1/4" Wrench x 1 piece
-  Click, Click Hinge (1 left, 1 right)
-  Stretcher Bars x 2 pieces 76"

Arms x 2 pieces

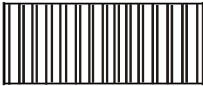
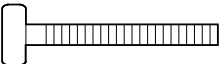

Left Arm Facing

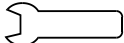
Wood Components and Hardware

-  Wood Seat x1 piece
-  Wood Back x1 piece
-  1/4" x 3 1/2" Black Allen Bolts x 8 pieces
-  1/4" Lock Nuts x 8 pieces
-  1/4" Flat Washers x 8 pieces
-  1/4" Wrench x 1 piece
-  Allen Key x 1 piece 1/4"

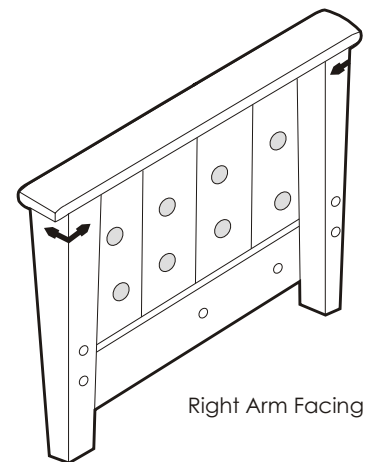

Right Arm Facing

IMPORTANT!! IMPORTANT!!

Do Not Operate Click- Click Hinges Until You Read These Simple Operations!!

Step #1 Bed to lounge position.

Pull up gently on the **center** of the seat to the point. (Approx. 120 degrees) where the hinges click on both sides. **IMPORTANT!** You must hear the hinges click on both sides. Then bring (push down) the seat down across the front stretcher bar. Now, the futon is in lounge position.

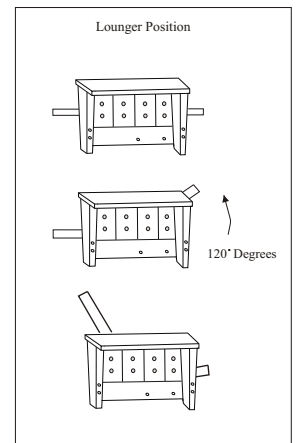

Step #2 Lounge to sofa position.

Pull up gently on the **center** of the seat to the point (approx. 90 degrees) until you hear a single click on both hinges. **IMPORTANT!** You must hear the hinges click on both sides. Then bring (push down) the seat down across the front stretcher. Now, the futon is in sofa position.

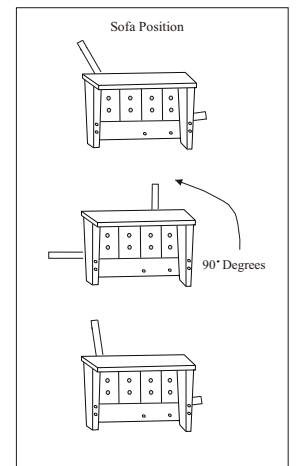

Step #3 Sofa to bed position.

Pull up gently on the **center** of the seat to a point (approx. 75 degrees) until you hear a single click on both hinges. **IMPORTANT!** You must hear the hinges click on both sides. Then bring (push down) the seat down across the front stretcher bar. Now the futon is in bed position.

