

# **Santa Barbara All Wood**

## **Assembly Instructions**

# **STOP!**

**Please read the following important information!**

For questions on assembly or parts, **DO NOT RETURN** product to the store. Contact the experts at **Elite Products** by calling **TOLL FREE.**

# **1-800-338-8667**

**Monday-Friday 8am-5pm (Pacific Standard Time)**

**elite**<sup>™</sup>  
**CONVERTIBLES**

By Elite Products

(Please keep this for future reference)

## Arms and Stretchers Assembly.

✓ Be sure the holes are free of wood chips and saw dust.

✓ Do not force the Bolt as you may strip thread. Be sure the thread is properly started.

✓ A Screwdriver will help you position the Barrel Nut in line with the bolt.

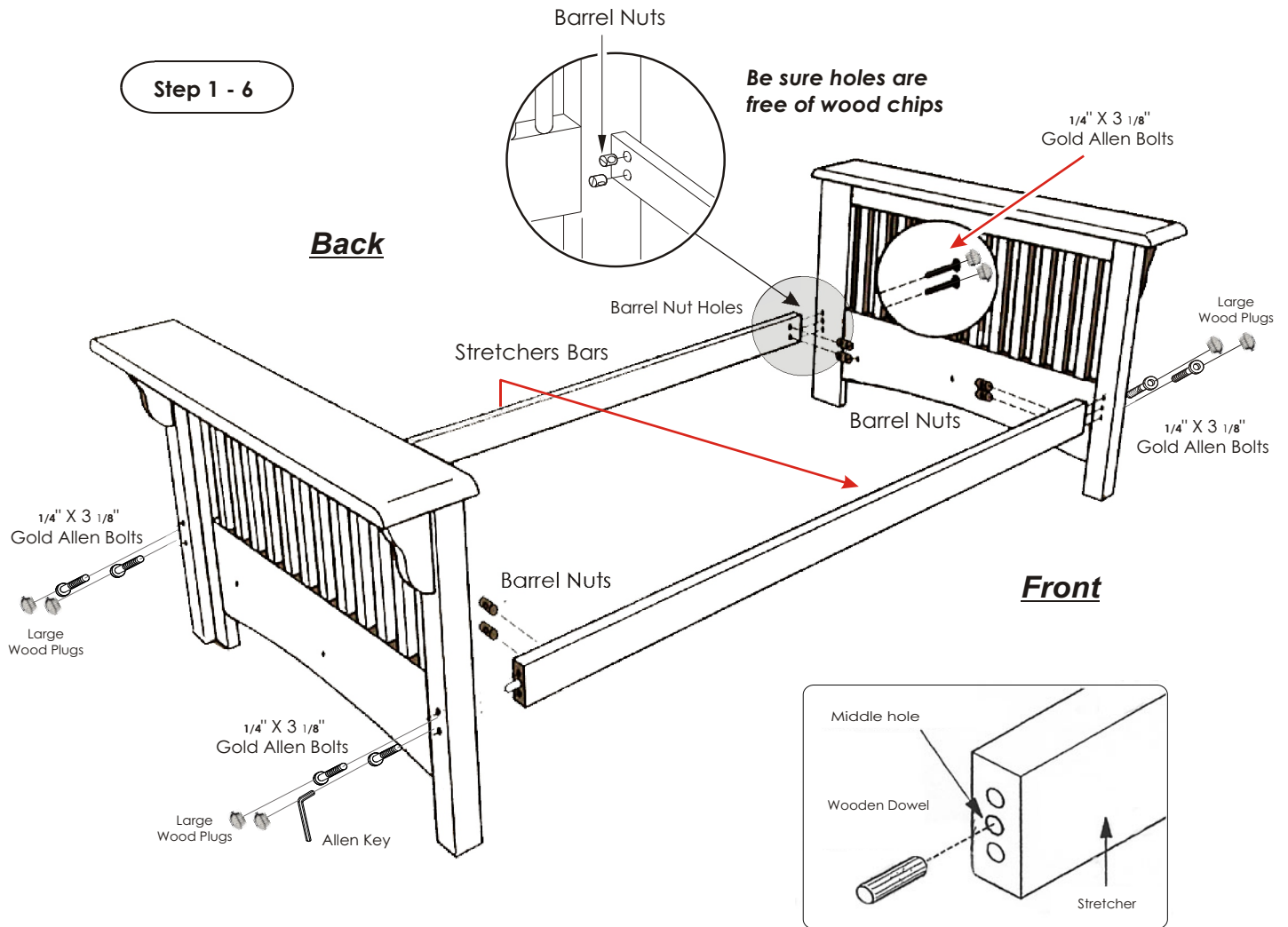

1. Please read all the instructions prior to assembly.
2. Attach stretcher bars to the arms using (2 Qty.) Gold Allen bolts & Barrel nuts and 1 Wooden dowel for each corner.
3. The stretcher bar holes should face towards inside of the frame.
4. Insert and tap (1Qty.) Wooden Dowel into the center of each stretcher bars, located on the ends.
5. Insert the barrel nuts into the holes with the screwdriver slots facing out.
6. Slide 1/4" x 3 1/8" Gold Allen bolts through holes in front legs of the arms and screw into barrel nuts.

**Note: Overhang on arm top should be facing outward**

## Assemble Hinge, Seat and Back Deck.

7. Secure hinges to arms using (2) 1 3/16" Gold allen bolts, (2 qty.) flat washers, and (2qty.) Lock nuts on each arm. Position the hinges (using the holes in the arms) more towards the back of the frame. **Completely tighten all hinge hardware.**

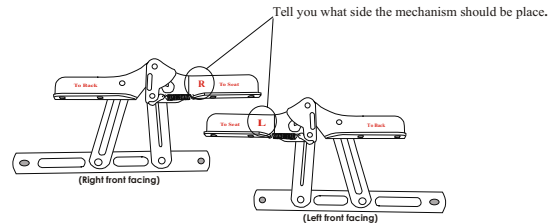
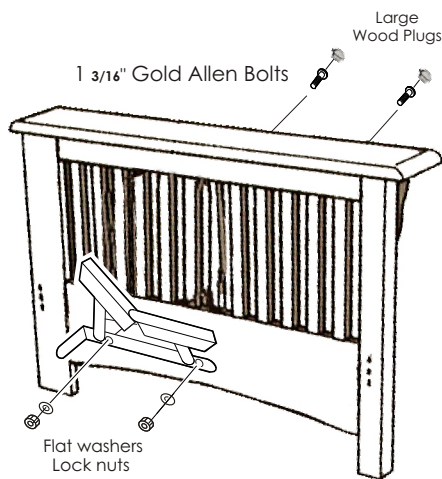

8. Install wood seat to hinge, using 3 1/4" black allen bolts, flat washers, lock nuts for each side. Repeat process for wood back installation. **Completely tighten all hardware.** After tightening hardware insert and tap (6 qty.) large wood plugs in holes of each arm.

### Step 8

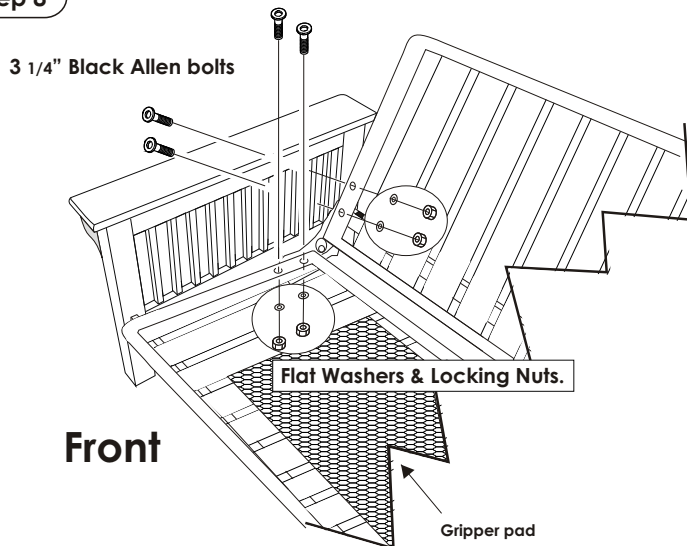

### Fit Wood buttons Into Bolt Holes

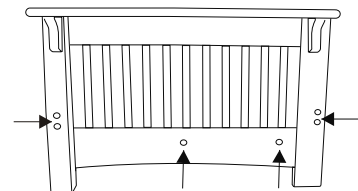

After assembling the Seat and Back Decks

Tighten all the Bolts. Push fit or lightly tap the Wood Buttons into the Arms.

Your futon is now assembled; Gripper, place gripper on wood seat prior to putting mattress in place.

## IMPORTANT!!!

Always operate sofa sleeper mechanism from front center of seat. See page 5 Operating Instructions

# Santa Barbara Assembly Instructions

For questions on assembly or parts, **DO NOT RETURN** this product to the store. Contact the experts at Elite Products by calling **TOLL FREE 1-800-338-8667**

## Parts List

### Wood Components and Hardware

Please check parts list for correct hardware count. If the futon arms came in a separate box some hardware may be packed inside. The quantities listed are the minimum required, you may receive extra hardware.

#### Arms and Stretcher Bar Hardware:



Allen Key x 2 pieces



1/4" x 3 1/8" Gold Allen Bolts x 8 pieces



1/4" x 1 3/16" Gold Allen Bolts x 4 pieces



Flat Washers x 4 pieces



5/16" Lock Nuts x 4 pieces



Barrel Nuts x 8 pieces

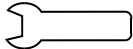

5/16" Wrench x1 piece

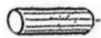

Wood Dowels x 4 pieces



Wood Buttons Large 5/8" x 12 pieces

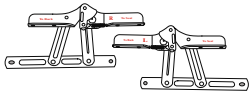

Click, Click Hinge (1 left, 1 right)



76 1/4" Stretcher Bars x 2 pieces

Arms x 2 pieces

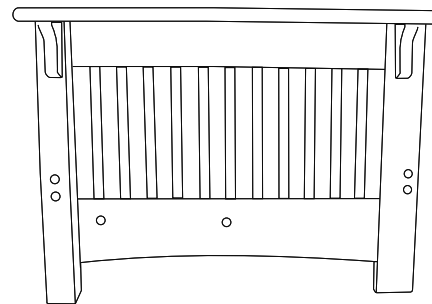

Left Arm Facing  
Inside frame

#### Seat and back Hardware:



Wood Seat x 1 piece

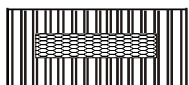

Wood Back x 1 piece



3 1/4" Gold Allen Bolts x 8 pieces



Flat Washers x 8 pieces



5/16" Lock Nuts x 8 pieces

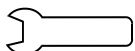

Wrench x1 piece

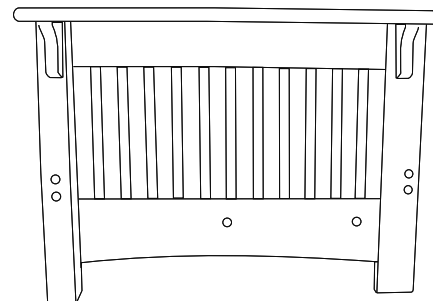

Right Arm Facing  
Outside Frame

# IMPORTANT!! IMPORTANT!!

## Do Not Operate Click- Click Hinges Until You Read These Simple Operations!!

### Step #1 Bed to lounger position.

Pull up gently on the **center** of the seat to the point. (Approx.120 degrees) where the hinges click on both sides. **IMPORTANT!** You must hear the hinges click on both sides .Then bring (push down) the seat down across the front stretcher bar. Now, the futon is in lounger position.

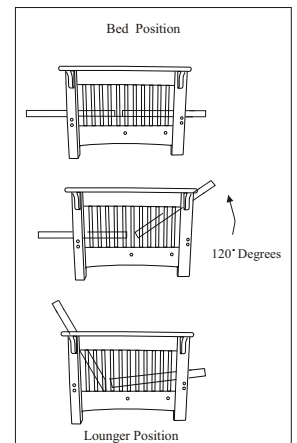

### Step #2 Lounger to sofa position.

Pull up gently on the **center** of the seat to the point (approx.90degrees) until you hear a single click on both hinges. **IMPORTANT!** You must hear the hinges click on both sides. Then bring (push down) the seat down across the front stretcher. Now, the futon is in sofa position.

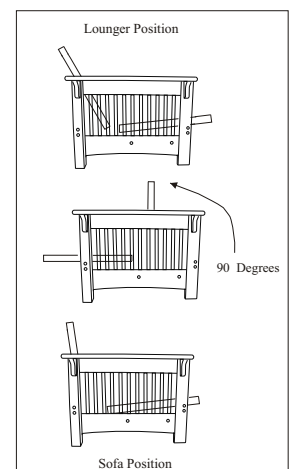

### Step #3 Sofa to bed position.

Pull up gently on the **center** of the seat to a point (approx.75 degrees) until you hear a single click on both hinges. **IMPORTANT!** You must hear the hinges click on both sides. Then bring (push down) the seat down across the front stretcher bar. Now the futon is in bed position.

