

BOSTON

ASSEMBLY INSTRUCTIONS

For questions regarding assembly
please call 888-FURNFX-1
or visit www.furniture-fx.com

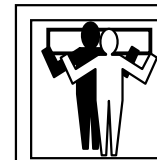

HEAVY WORK !!
3 people required
to perform this exercise

BOX # 1 OF 2

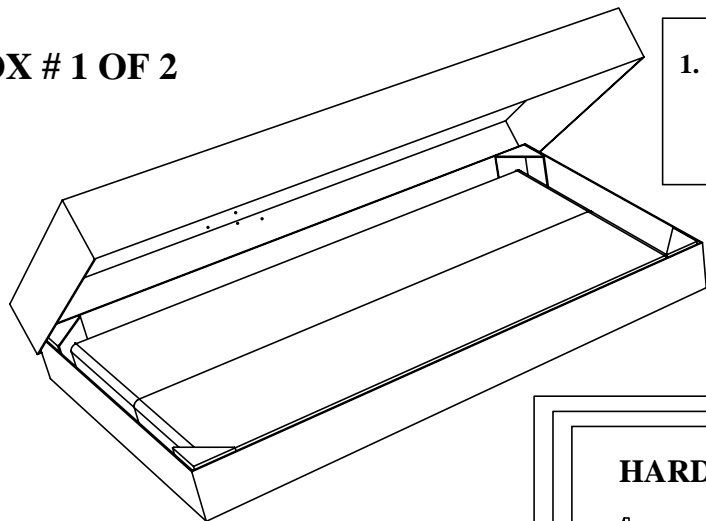

1. Avoid using sharp object such as a knife to cut open the interior plastic packing as you may accidentally damage the sofa fabric.

BOX # 2 OF 2

Arm - 1 pair.

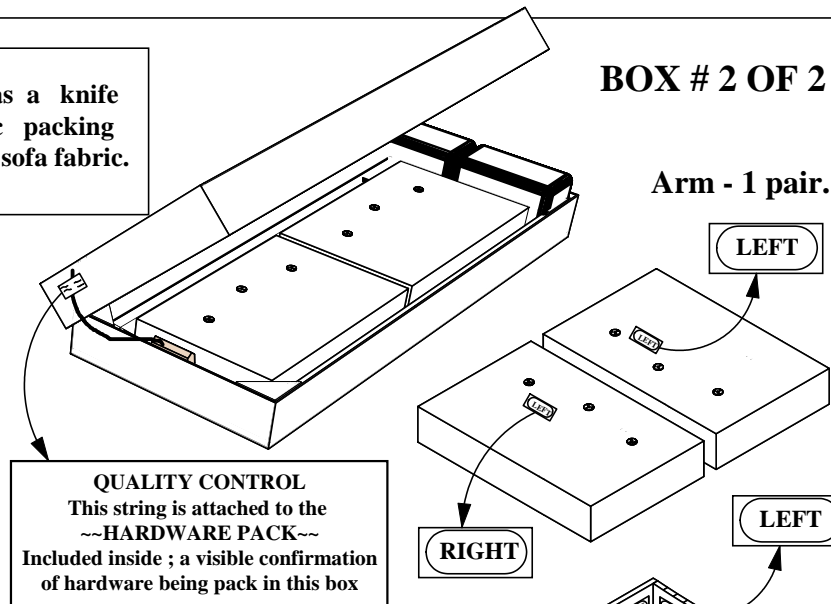

QUALITY CONTROL
This string is attached to the
~~HARDWARE PACK~~
Included inside ; a visible confirmation
of hardware being pack in this box

HARDWARE IN THIS BOX



Bolt A - M8 x 60 mm 6 pcs.



Bolt B - M8 x 30 mm 4 pcs.

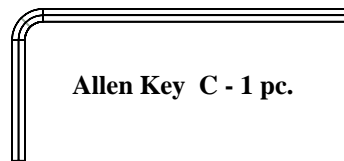

Allen Key C - 1 pc.



Washer E - 6 pcs.

Storage - 1 pc.

RIGHT

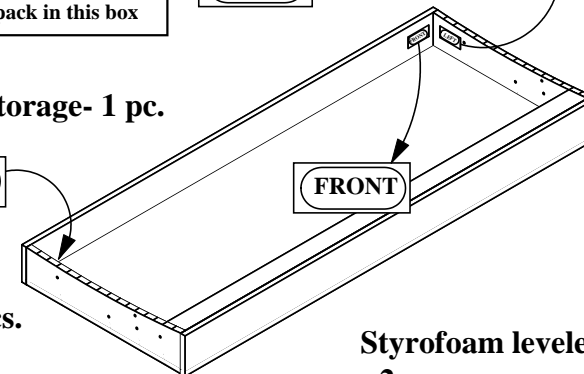

FRONT

Wood Leg - 4 pcs.

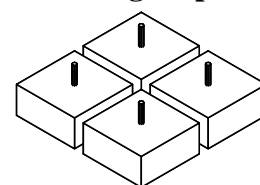

Pillow - 2 pcs.

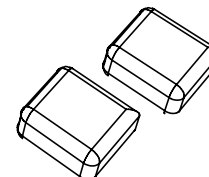

Styrofoam leveler
- 2 pcs

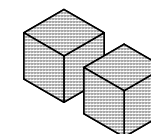

Sofa Bed - 1 pc.

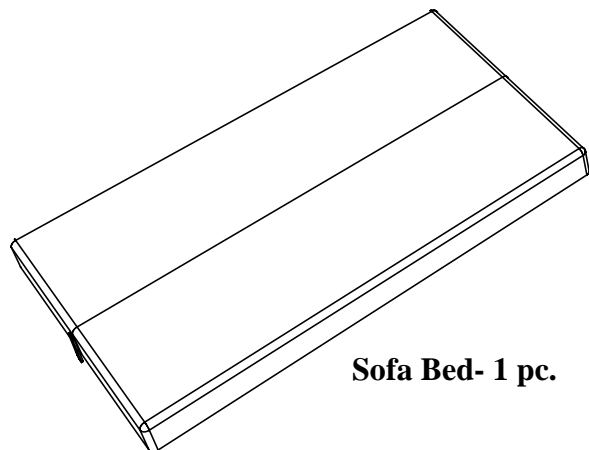

2. Carefully place the sofa bed on the storage base and attach metal bracket to storage base using Bolt B 2 pcs per side as shown in diagram 2.

Diagram 1

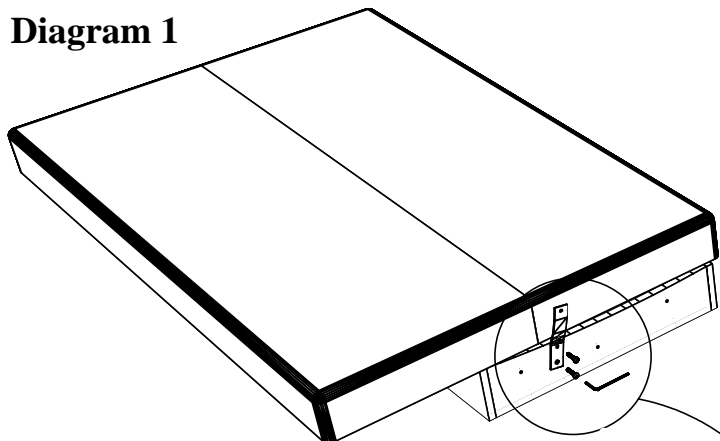

Diagram 2

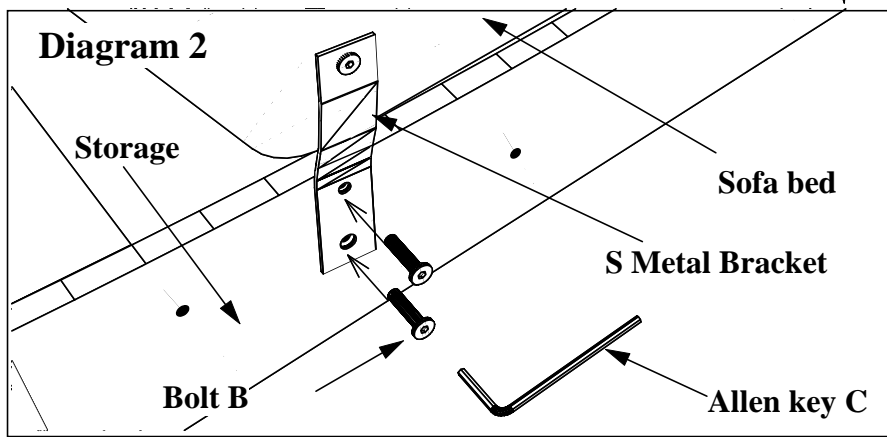
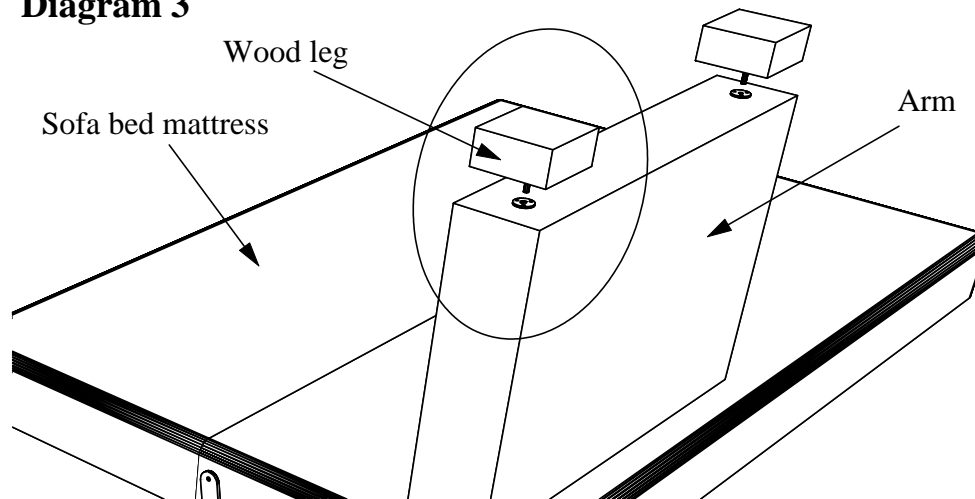

Diagram 3



3. Attach wood leg to the bottom of the Arm rest . Make sure the legs are tighten aligned.

Diagram 4

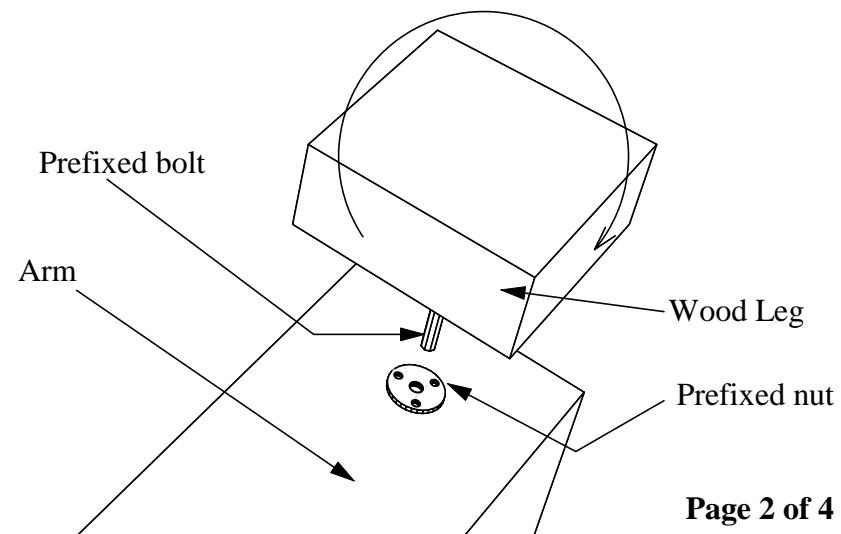

Diagram 5

4. Convert sofa bed into sofa position and use leveler at front and back to level the storage to line up with the holes in the arm.
Then attach the arms using 6 pcs of Bolt A and Washer E as shown in diagram 5 and 6.
Repeat the same step to attach the other side of the arm.

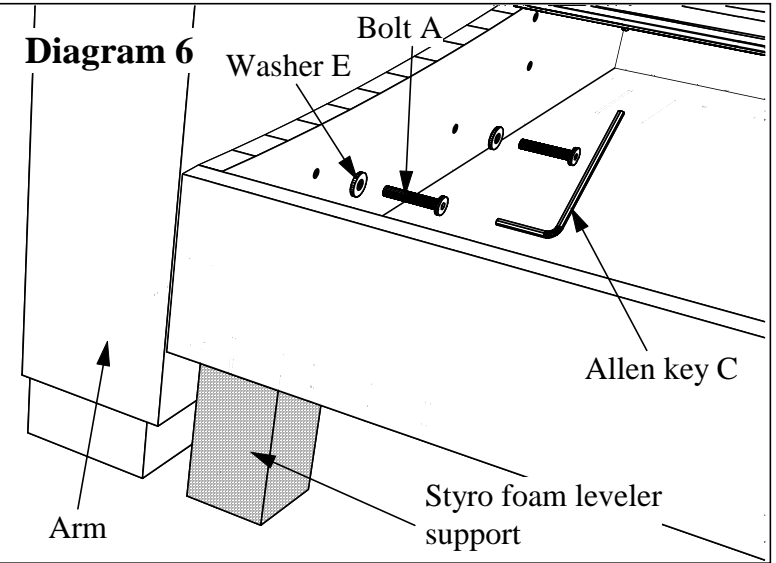
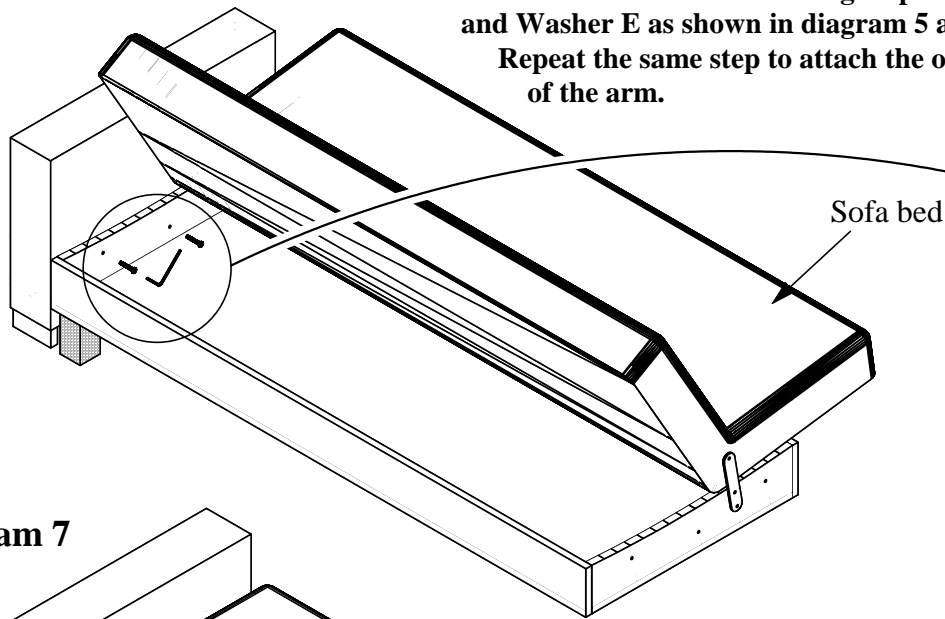
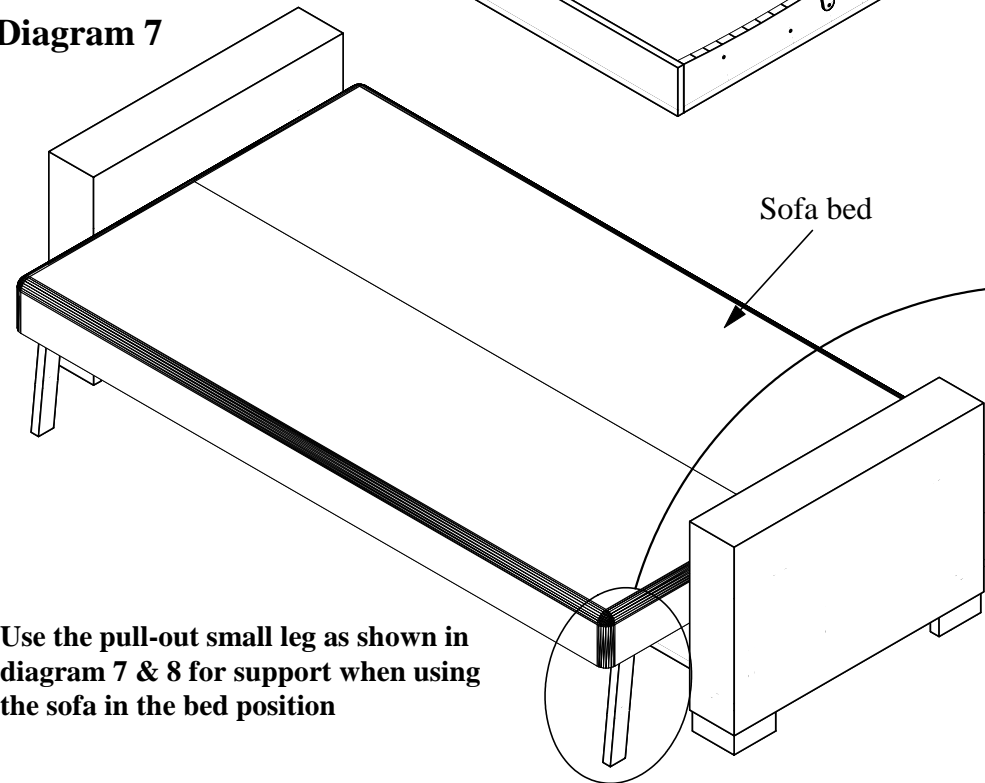
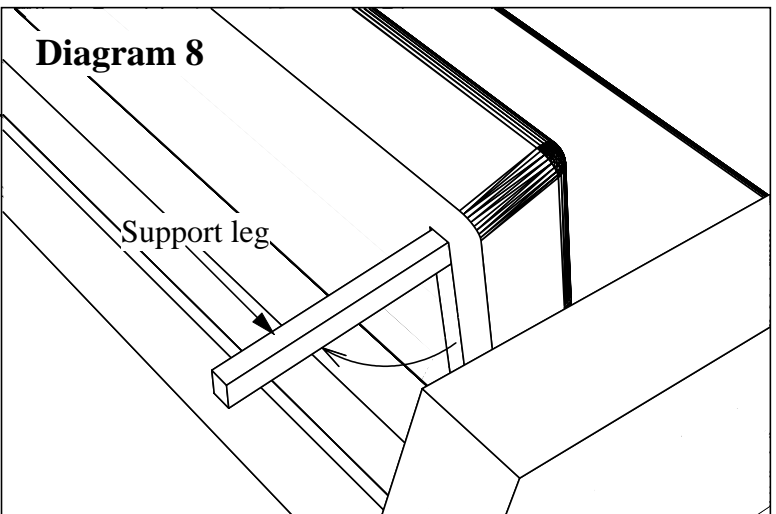
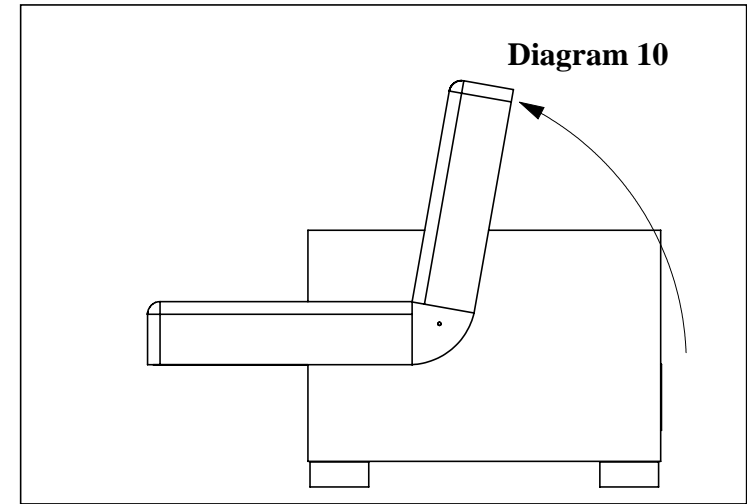
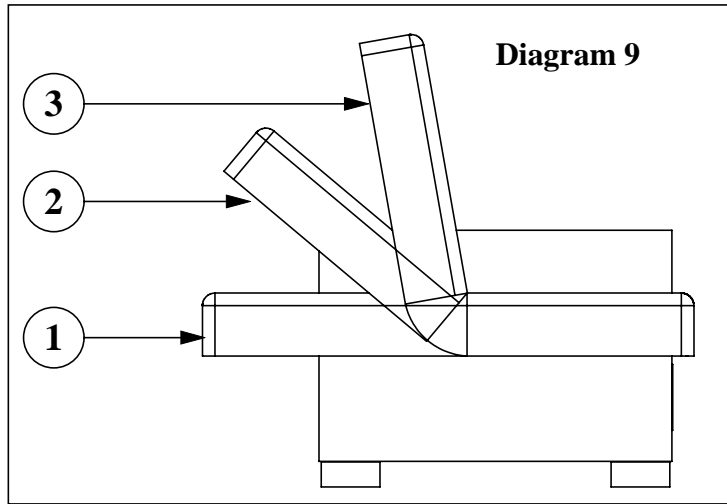

Diagram 7



5. Use the pull-out small leg as shown in diagram 7 & 8 for support when using the sofa in the bed position





1. The sofa bed has 3 positions shown in diagram 9. Bed (1), Lounge (2), Sofa (3).
2. To convert sofa bed to its desired positions stand in the middle at the back . Push the back section forward slowly to release the mechanism. Gently guide the back down to the bed position.
3. To convert the sofa to lounge position stand in the middle at the back of the sofa bed and simply lift the back up to the desired position. Make sure that the two sides of the locking mechanism lock at the same angle.

4. To return the sofa back to the sofa position , Lift the back all the way to its most up right position until the final clicking position of the sofa mechanism is heard.

(To repeat steps 2-4) slowly release the back of the sofa back to the bed position.
5. To open the storage, from sofa position lift up seat deck from front. Diagram 10.

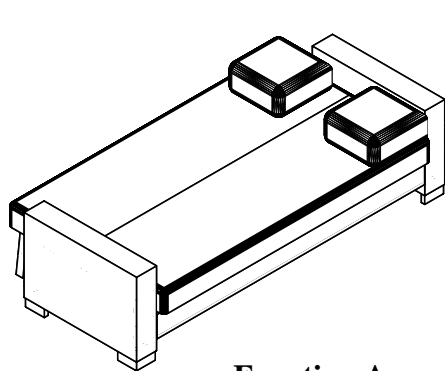

Function A

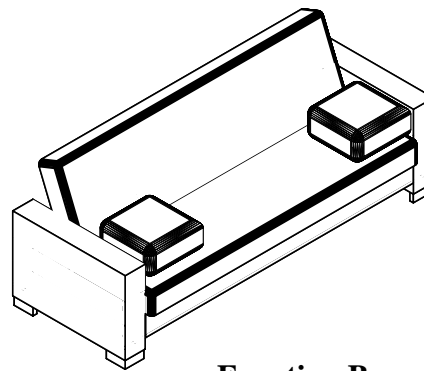

Function B

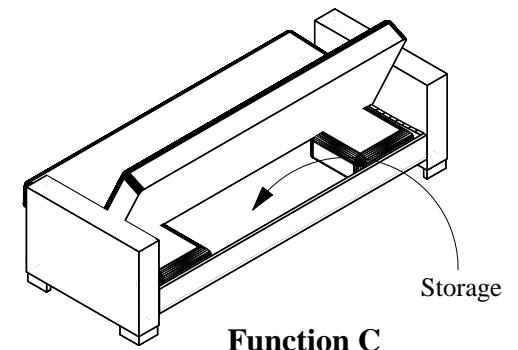

Function C