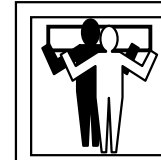


# NEW HAMPSHIRE

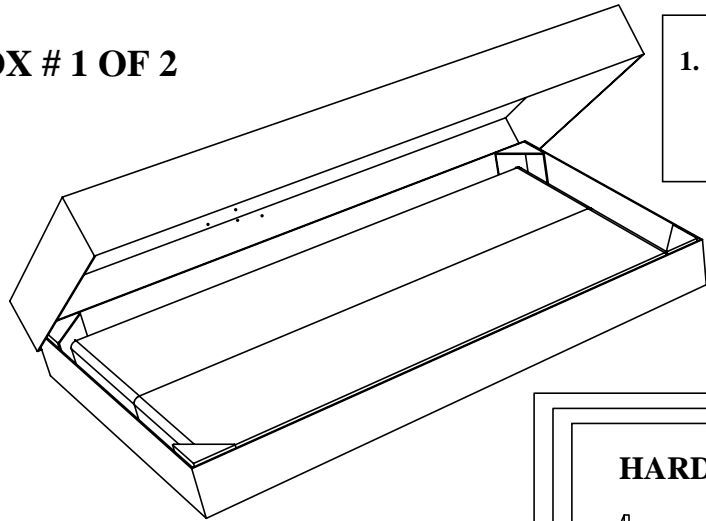
## ASSEMBLY INSTRUCTIONS

For questions regarding assembly  
please call 888-FURNFX-1  
or visit [www.furniture-fx.com](http://www.furniture-fx.com)



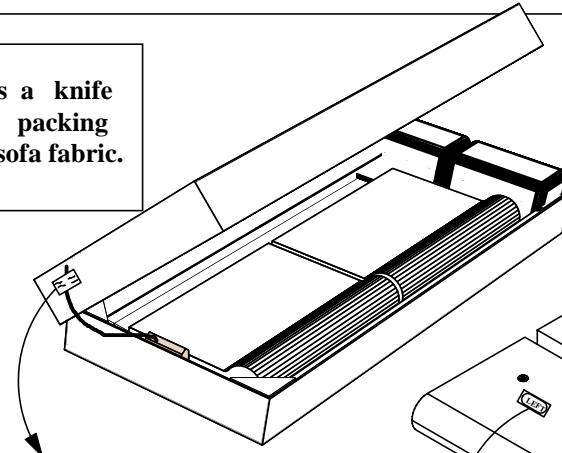
**HEAVY WORK !!**  
3 people required  
to perform this exercise

**BOX # 1 OF 2**



1. Avoid using sharp object such as a knife to cut open the interior plastic packing as you may accidentally damage the sofa fabric.

**BOX # 2 OF 2**



Arm - 1 pair.

LEFT

LEFT

RIGHT

**QUALITY CONTROL**  
This string is attached to the  
--HARDWARE PACK--  
Included inside ; a visible confirmation  
of hardware being pack in this box

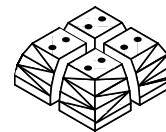
Storage- 1 pc.

RIGHT

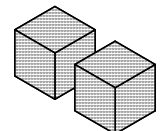
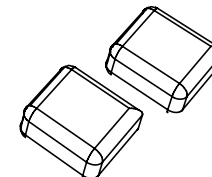
FRONT

Wood Leg - 4 pcs.

Styrofoam leveler  
- 2 pcs



Pillow - 2 pcs.



Page 1 of 4

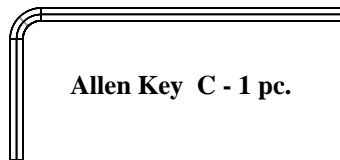
**HARDWARE IN THIS BOX**



Bolt A - M8 x 60 mm 6 pcs.



Bolt B - M8 x 30 mm 4 pcs.



Allen Key C - 1 pc.

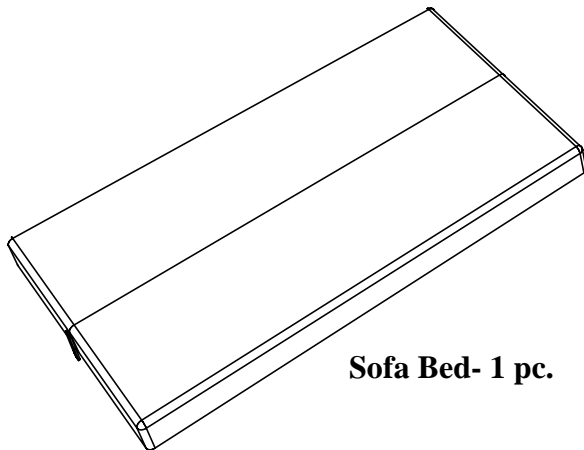


Screw D - 8 pcs.



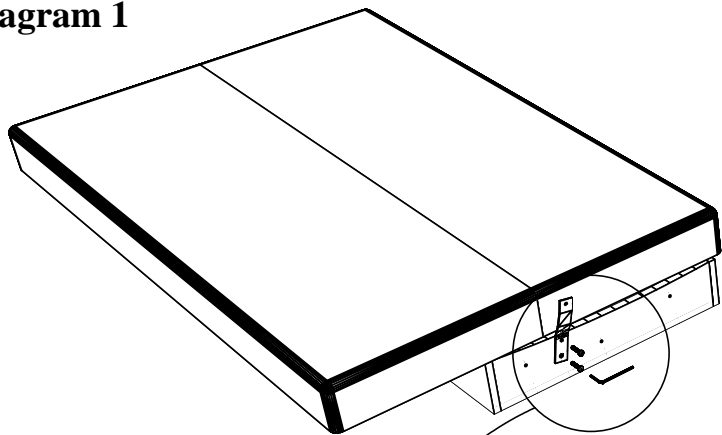
Washer E - 6 pcs.

Sofa Bed- 1 pc.

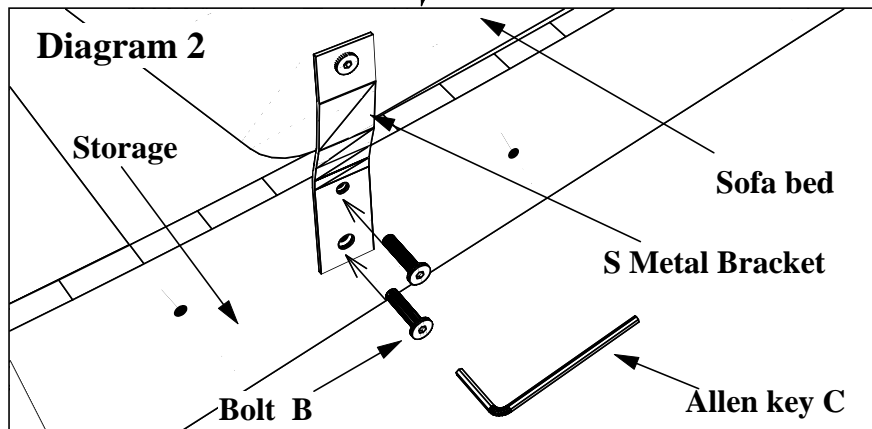


2. Carefully place the sofa bed on the storage base and attach S metal bracket to storage base using Bolt B 2 pcs per side as shown in diagram 2.

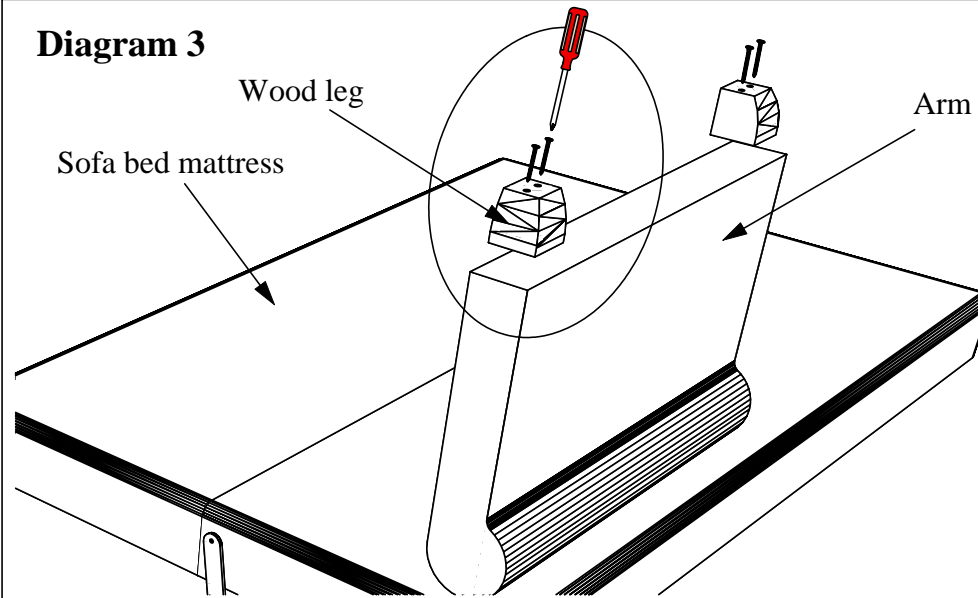
**Diagram 1**



**Diagram 2**

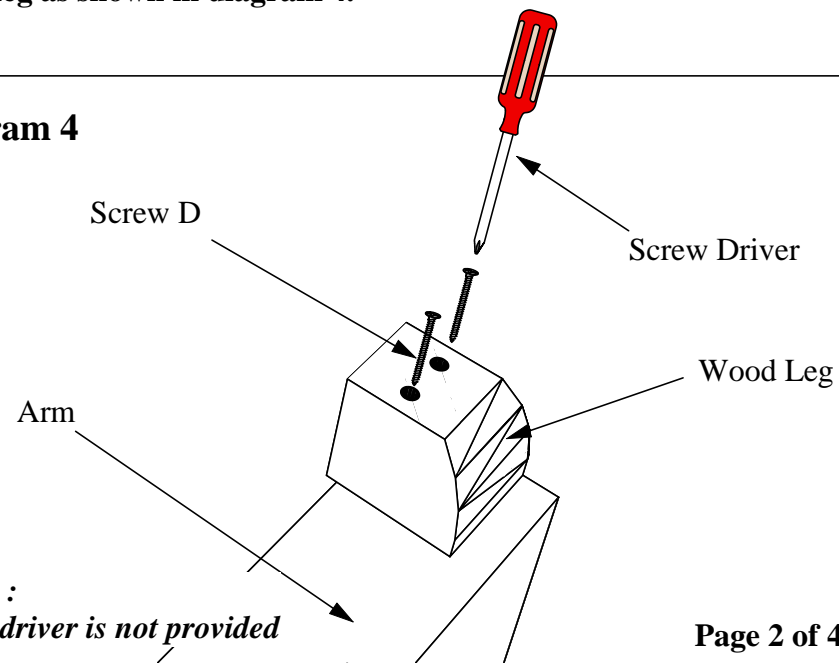


**Diagram 3**



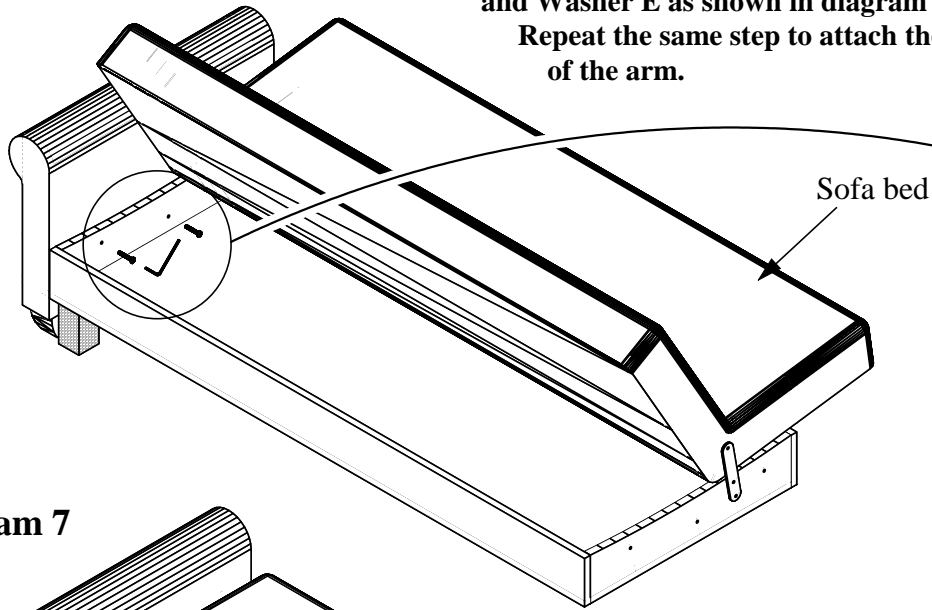
3. Attach wood leg to the bottom of the Arm rest . Use screw D -2 pcs per leg as shown in diagram 4.

**Diagram 4**



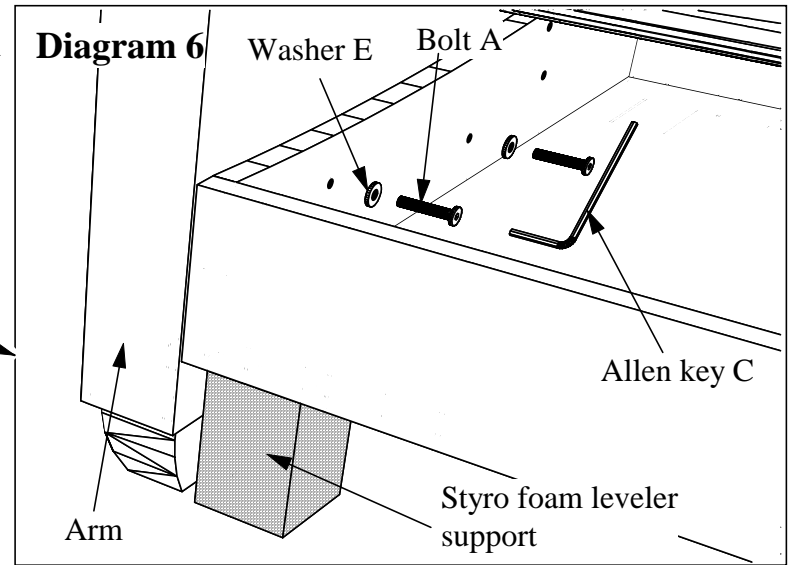
**NOTE :**  
*Screw driver is not provided*

**Diagram 5**

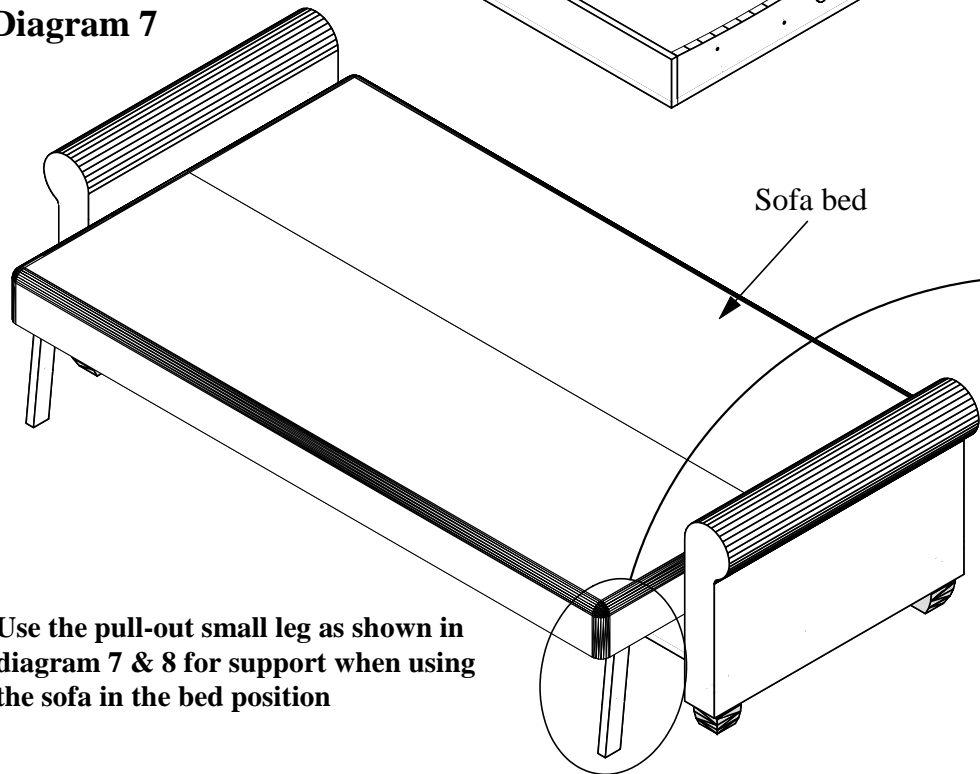


4. Convert sofa bed into sofa position and use leveler at front and back to level the storage to line up with the holes in the arm. Then attach the arms using 6 pcs of Bolt A and Washer E as shown in diagram 5 and 6. Repeat the same step to attach the other side of the arm.

**Diagram 6**

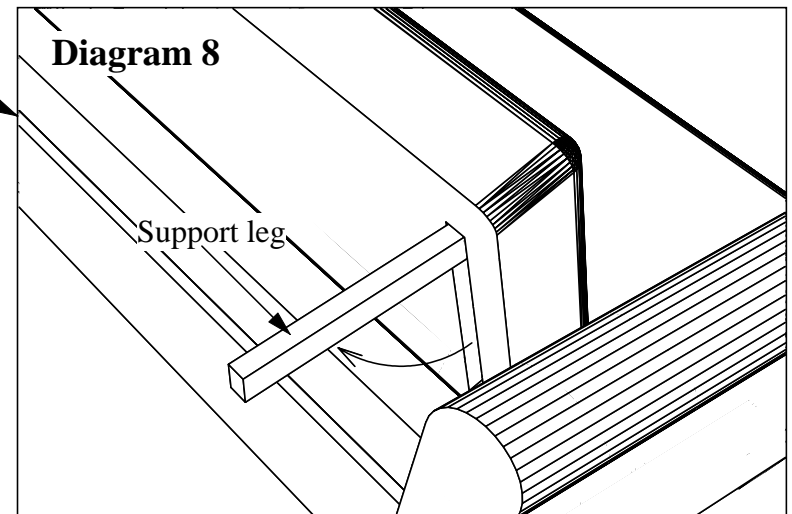


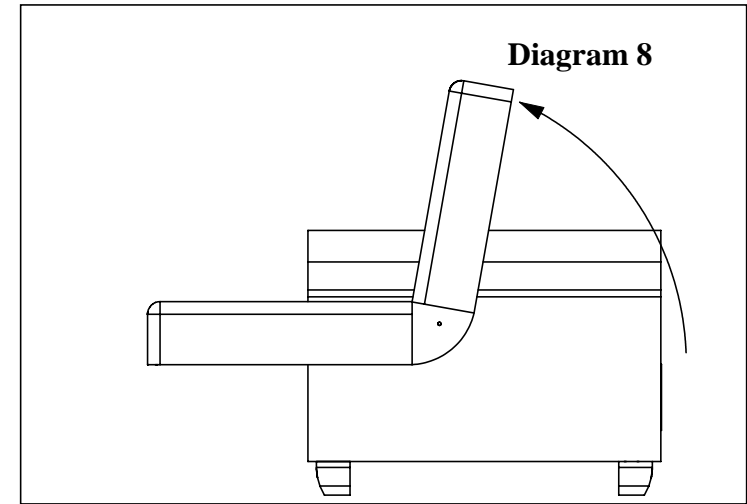
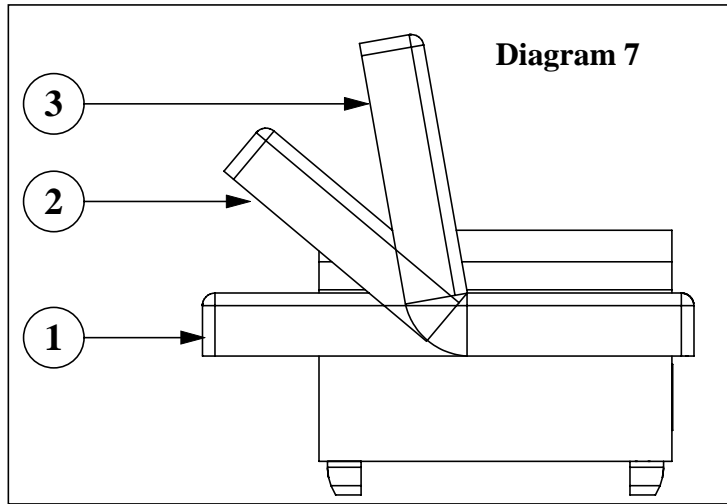
**Diagram 7**



5. Use the pull-out small leg as shown in diagram 7 & 8 for support when using the sofa in the bed position

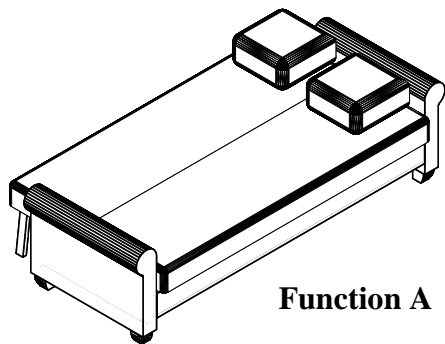
**Diagram 8**



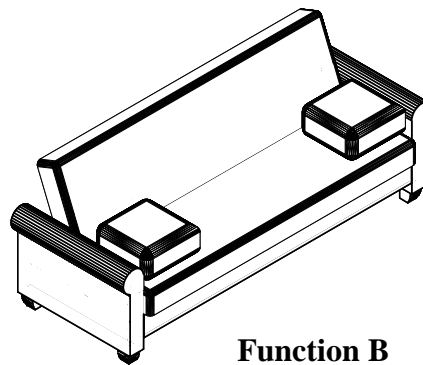


1. The sofa bed has 3 positions shown in diagram 7. Bed ( 1 ), Lounge ( 2 ), Sofa ( 3 ).
2. To convert sofa bed to its desired positions stand in the middle at the back . Push the back section forward slowly to release the mechanism. Gently guide the back down to the bed position.
3. To convert the sofa to lounge position stand in the middle at the back of the sofa bed and simply lift the back up to the desired position. Make sure that the two sides of the locking mechanism lock at the same angle.

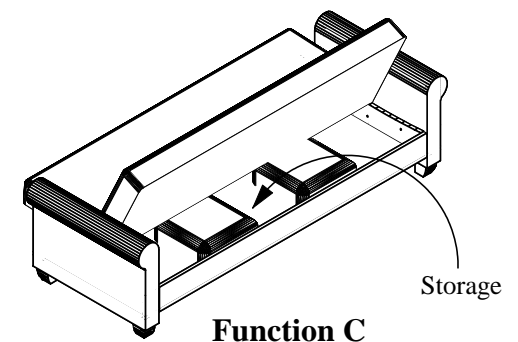
4. To return the sofa back to the sofa position , Lift the back all the way to its most up right position until the final clicking position of the sofa mechanism is heard.
- (To repeat steps 2-4) slowly release the back of the sofa back to the bed position.
5. To open the storage, from sofa position lift up seat deck from front. Diagram 8.



**Function A**



**Function B**



**Function C**

Storage