

Worktable with Tubular Base

ASSEMBLY INSTRUCTIONS

CAUTION

INSPECT CONTENTS IMMEDIATELY AND FILE CLAIM WITH DELIVERING CARRIER FOR ANY DAMAGE.

SAVE YOUR BOX AND ALL PACKING MATERIALS.
YOU ARE RESPONSIBLE FOR DAMAGE TO YOUR UNIT
IF RETURNED IMPROPERLY PACKED.

Please note: Assembly shown for unit with six legs.

Step 1 - Assemble crossbrace subassembly.

- Assemble middle, corner, and end castings to rear knockdown tube and front-to-back crossbracing.
- Tighten set screws.

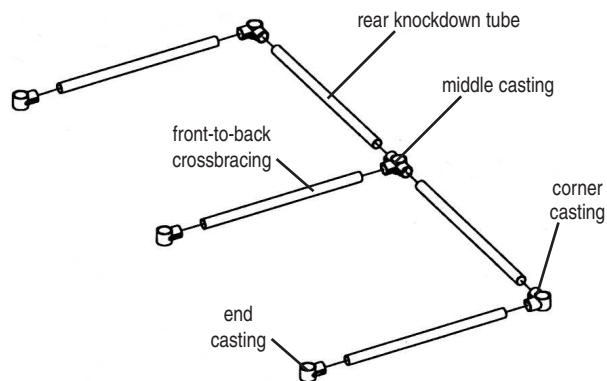

Step 2 - Attach crossbrace subassembly to legs.

Note: To meet NSF requirements, attach crossbrace subassembly 6" from floor.

- On legs, measure and mark desired height of crossbrace subassembly.
- Insert legs.
- Snug the set screws.

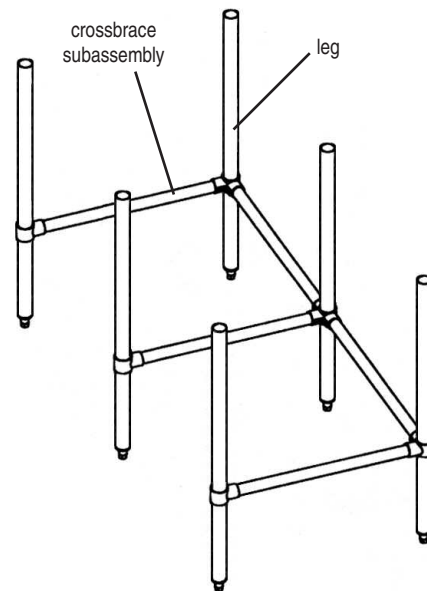

(continued on back page)

Worktable with Tubular Base

ASSEMBLY INSTRUCTIONS

Step 3 - Attach tabletop.

- Turn tabletop upside-down (take care not to scratch the finish).
- Turn crossbrace subassembly upside-down and insert top of each leg into each tabletop gusset.
- Tighten all screws.

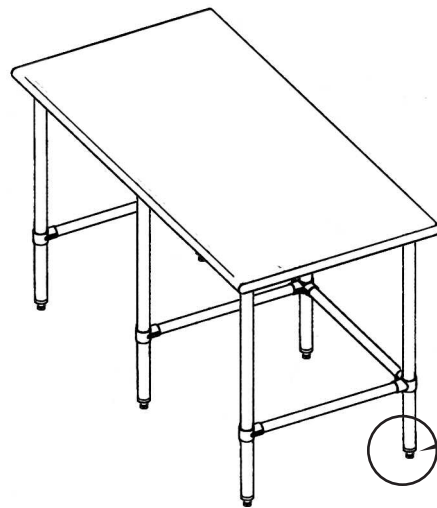
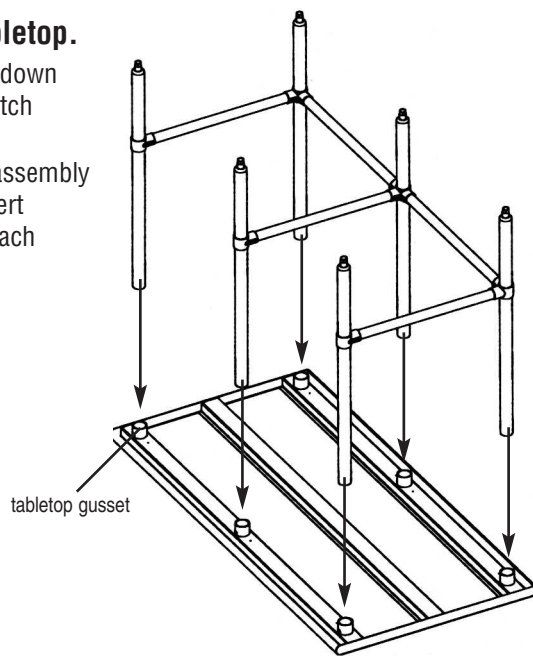

Level table with adjustable feet.

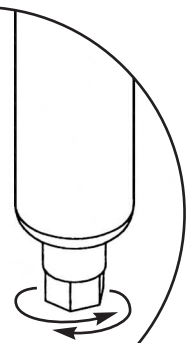

Assembly is complete.

(End)

EAGLE
GROUP

Profit from the Eagle Advantage®

• 100 Industrial Boulevard, Clayton, Delaware 19938-8903 U.S.A. • www.eaglegrp.com
• Phone: 302/653-3000 • (Foodservice) 800/441-8440 • (MHC/Retail) 800/637-5100
• Fax: 302/653-2065

Eagle Foodservice Equipment, Eagle MHC, SpecFAB, and Retail Display are divisions of Eagle Group. ©2007 by the Eagle Group