

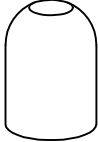



# Kwik-File





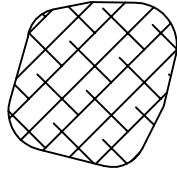
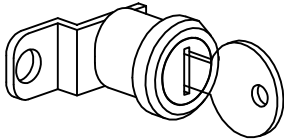
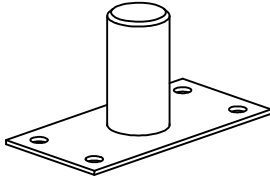
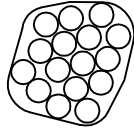

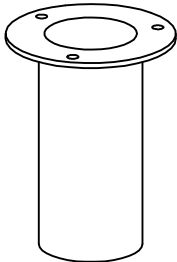
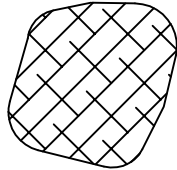
## ARC Rotary File Instruction Sheet

Hardware Box (LARCKIT & GARCKIT) Consist of:

<p><b>BASE STOP PLUNGER</b> 912251</p>  <p><b>Replacement Part: 912251R</b></p>	<p><b>BASE STOP SPRING</b> 912252</p>  <p><b>Replacement Part: 912252R</b></p>	<p><b>HARDWARE KIT ARC CAPS AND PLUGS</b> 913043</p>  <p><b>Replacement Part: 913043R</b></p>
<p><b>LOCK</b> 9000012</p>  <p><b>Replacement Part: 9000012R</b></p>	<p><b>TOP PAN SHAFT</b> 84080300</p>  <p><b>Replacement Part: 84080300R</b></p>	<p><b>BEARINGS</b> 918109 LETTER QTY (19) LEGAL QTY (25)</p>  <p><b>Replacement Part: 918109R - Kit of (25)</b></p>
<p><b>BRONZE BEARING</b> 918106</p>  <p><b>Replacement Part: 918106R</b></p>	<p><b>BASE STOP CUP</b> 912250</p>  <p><b>Replacement Part: 912250R</b></p>	<p><b>HARDWARE KIT ARC FASTENERS</b> 913044</p>  <p><b>Replacement Part: 913044R</b></p>



# Hardware Box (LARCKIT & GARCKIT) Con't:

## Bag #913044 - HDWR KIT ARC FASTENERS

- 1 - 1/16" X 1/2" LONG COTTER PIN
-  3 - SCREW TEKS 10-16x1/2 PH PAN HD
-  12 - U-NUT 1/4-20 END PNL
-  14 - NUT 1/4-20 WITH STAR WASHER
-  32 - SCREW PAN HEAD MACH 1/4-20X1/2"L
-  12 - SCREW FLAT HEAD MACH 1/4-20X1/2"L
-  8 - SCREW #10 X 1/2"

**Replacement  
Part #  
913044R**

## Bag #913043 - HDWR KIT ARC CAPS & PLUGS

- 2 - HEYCO LOCKIT MOUNTING HOLE PLUGS
-  8 - FLAT BTM 1/4" SNAP
-  8 - BROOKER BEIGE SNAP CAP (12/12-120)
- 8 - MORNING GRAY SNAP CAP (12/12-170)
- 8 - BLACK SNAP CAP (12/12-180)

**Replacement  
Part #  
913043R**

## Remaining Components:

- |   | <b>Replacement<br/>Part #</b> |
|---|-------------------------------|
| 1 - Top Pan Shaft -----                     | <b>84080300R</b>              |
| 1 - Lock 5/8" Keyed Alike PJ3402 -----      | <b>9000012R</b>               |
| 1 - Base Stop Cup -----                     | <b>912250R</b>                |
| 1 - Base Stop Plunger -----                 | <b>912251R</b>                |
| 1 - Base Stop Spring -----                  | <b>912252R</b>                |
| 1 - Bearing 1.002" ID X 1" LENGTH -----     | <b>918106R</b>                |
| 19 - Ball Bearing 5/8" (Letter Units) ----- | <b>918109R</b>                |
| 25 - Ball Bearing 5/8" (Legal Units) -----  | <b>918109R</b>                |

# **Kwik-File ARC Rotary File**

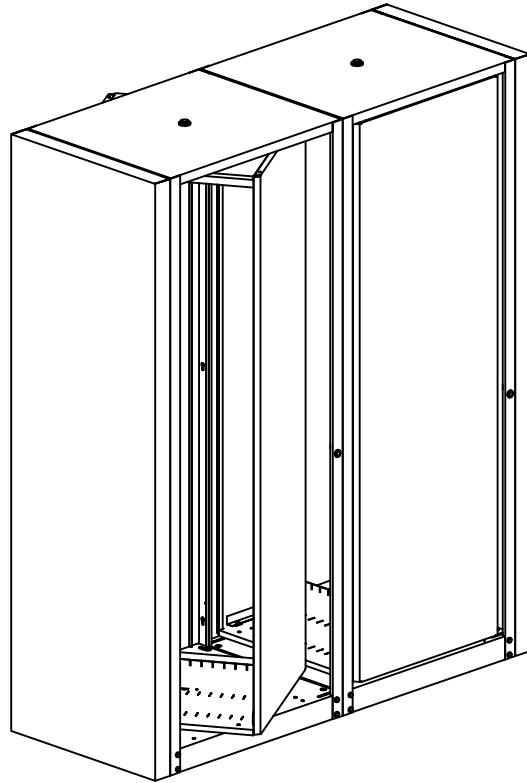

*Verify components and quantities per factory packing list.*

*Assembly requires two people.*

*The floor should be firm so that the ARC is effectively leveled.*

*Measure actual space that your system will occupy and compare with layout sketch. Also note configuration of ARC units if more than one unit is involved.*

*When positioning ARC unit, place letter unit no closer than 5-1/4" from wall, legal unit no closer than 6-1/2" from wall.*

# Required Tools:

- 1.) Bubble level
- 2.) Power screwdriver with #2 & #3 phillips head driver
- 3.) Ratchet with 7/16" socket & 1/4" socket
- 4.) Ladder

# Arc Component Identification:

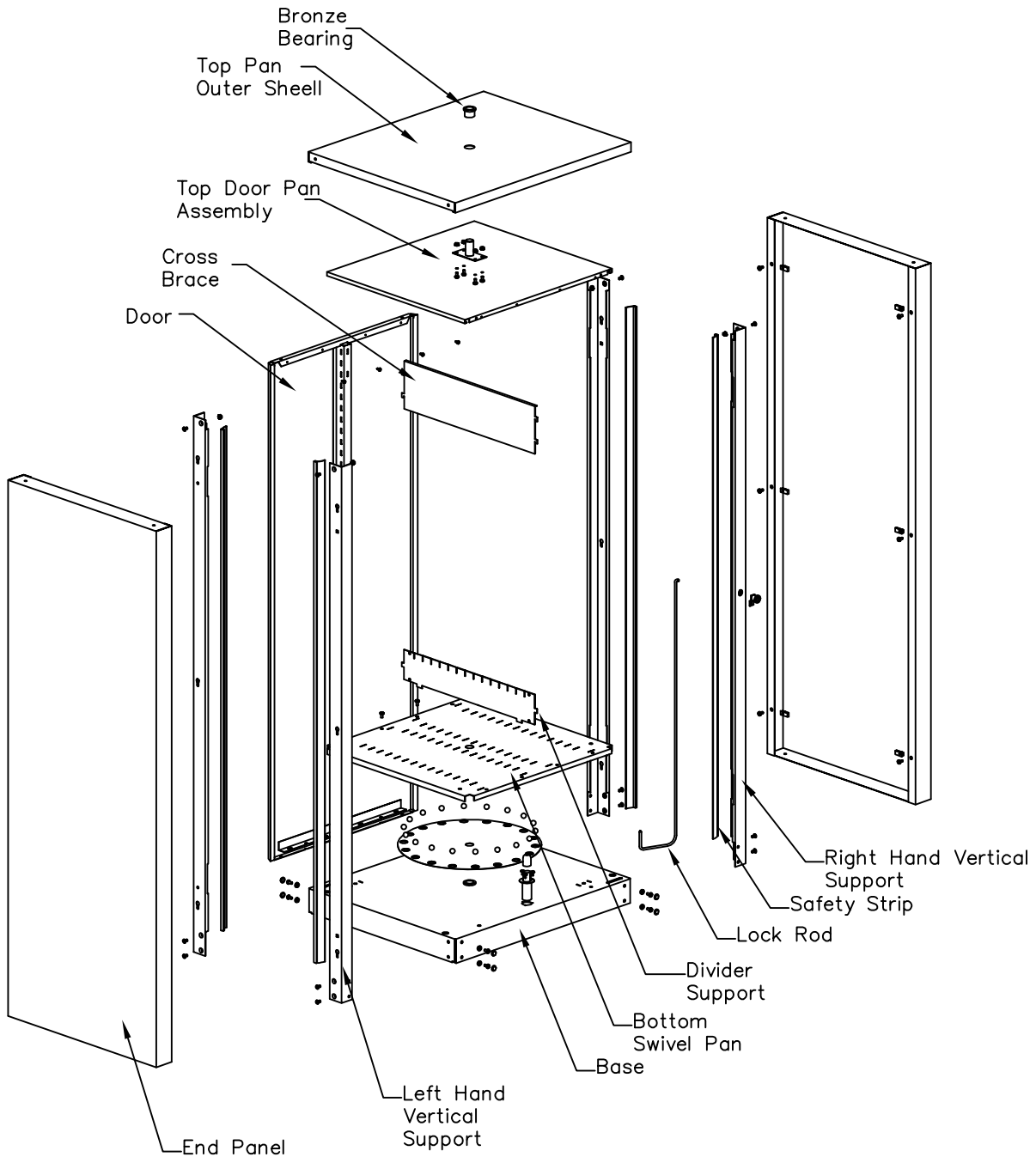

# 1. Arc Base

Position base so base stop hole is facing into the install room. Remove the bottom swivel pan. (Fig. 1.1) Install the base stop cup, spring & plunger. The stop cup is secured to the base by using (3) 10–16x1/2" Phillips Pan Head screws and pre-drilled holes in base (Fig. 1.2).

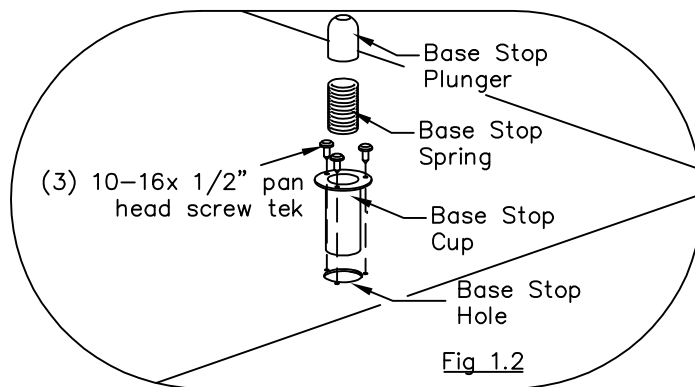
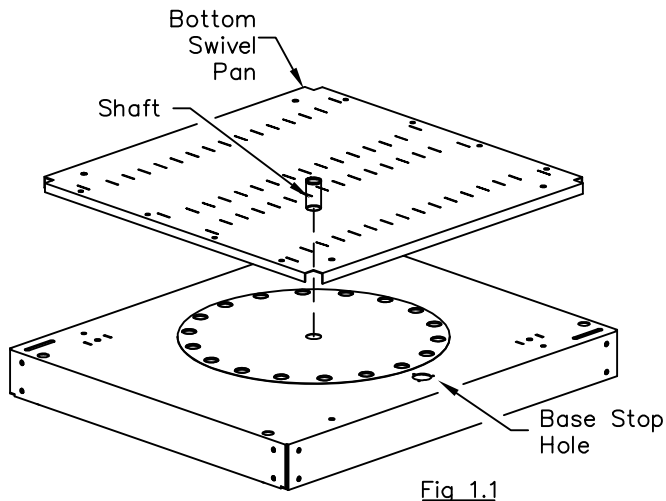

Add ball bearings to the bearing plate

NOTE: The extruded side of the bearing plate should be facing up.

A letter base will use 18 bearings and the legal base will use 24 bearings (1 extra is included with each bag). Place the ball bearings in each extruded hole.

Replace top swivel pan by slowly lowering the shaft on the under side of the bottom swivel pan into the stationary base. Check for proper rotation. Remove ATTENTION label from swivel pan (Fig 1.3)

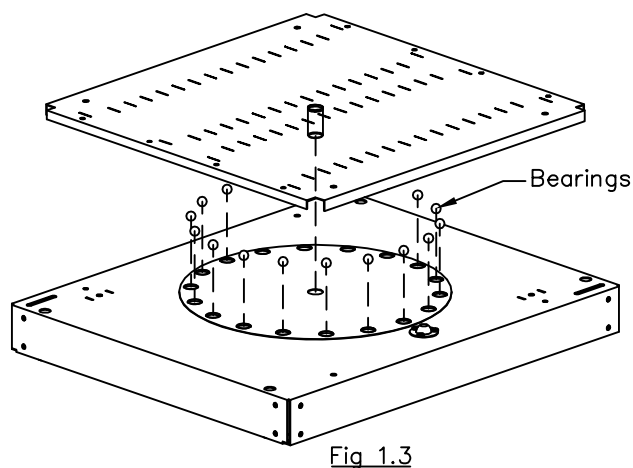

## 2. Vertical Supports

Install Left/Right hand Vertical Supports (Fig. 2.1). The Right hand Vertical Support contains the lock hole plug.

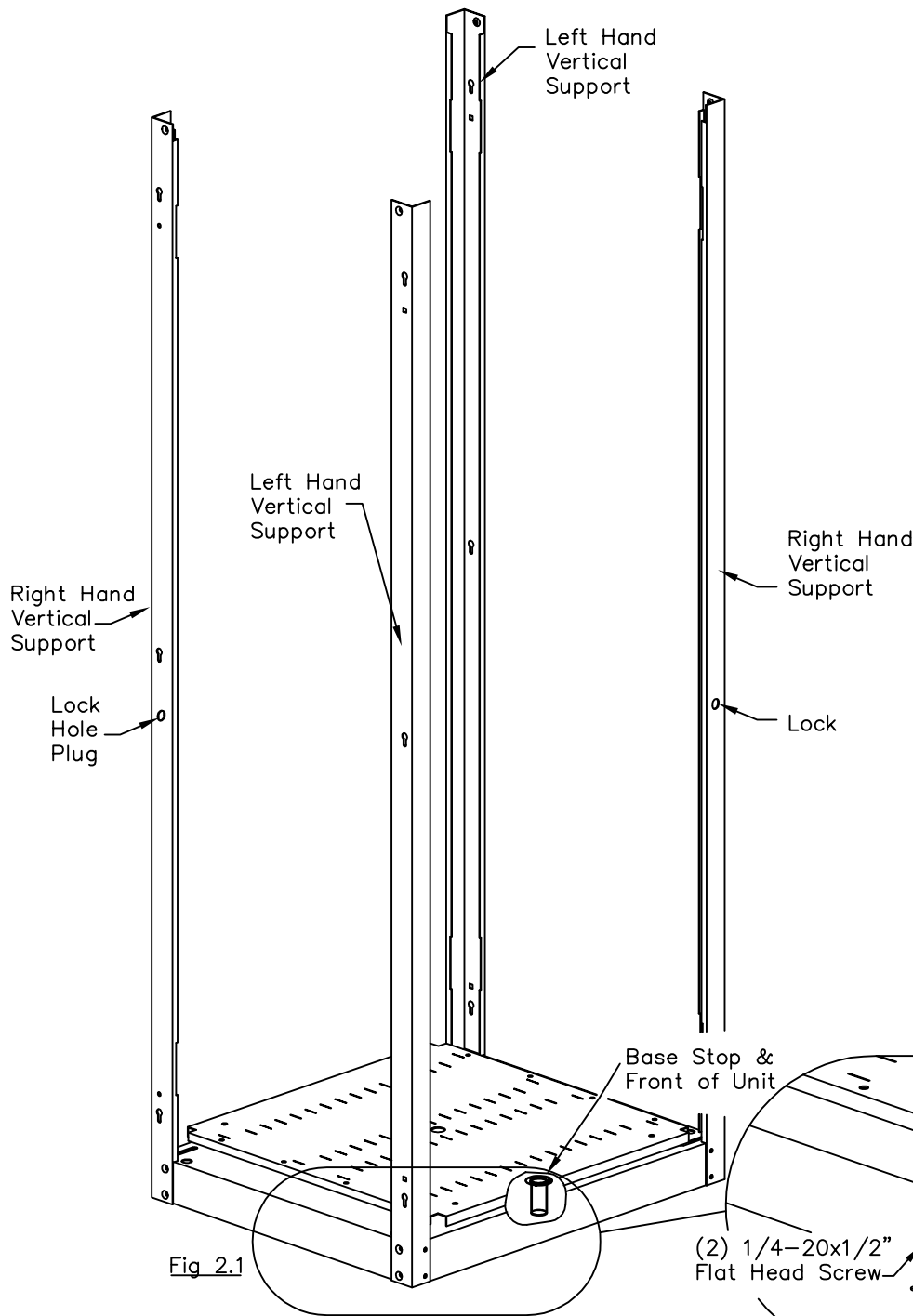

Install (2)  
1/4-20x1/2" Flat  
Head Screws. Do not  
fully tighten.

Install (2)  
1/4-20x1/2" Pan  
Head Screws. Slide  
Pan Head Screw thru  
the Bottom Snap  
Caps and then screw  
into the threaded  
hole. Tighten all (4)  
screws. Push Snap  
Caps (three color  
options are provided)  
onto Bottom Snap  
Cap.

(Fig. 2.2) Repeat for  
(3) remaining vertical  
supports.

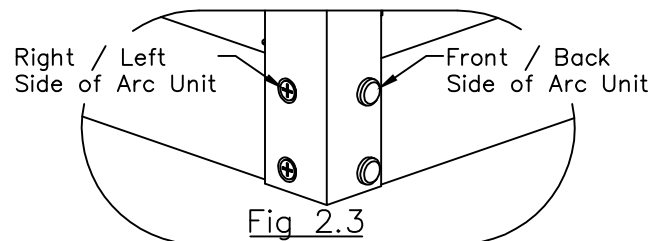
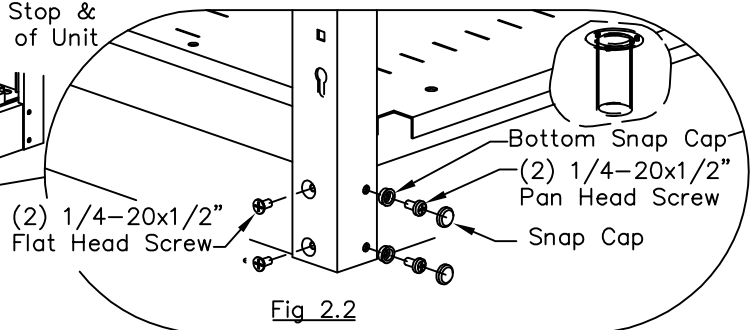

### 3. Doors

Install (2) doors, cross brace & divider support. Place the divider support into the two slots in the bottom swivel pan. Slide the first door onto the bottom swivel pan. Verify that tab on divider support engages into the door. (Fig. 3.1)

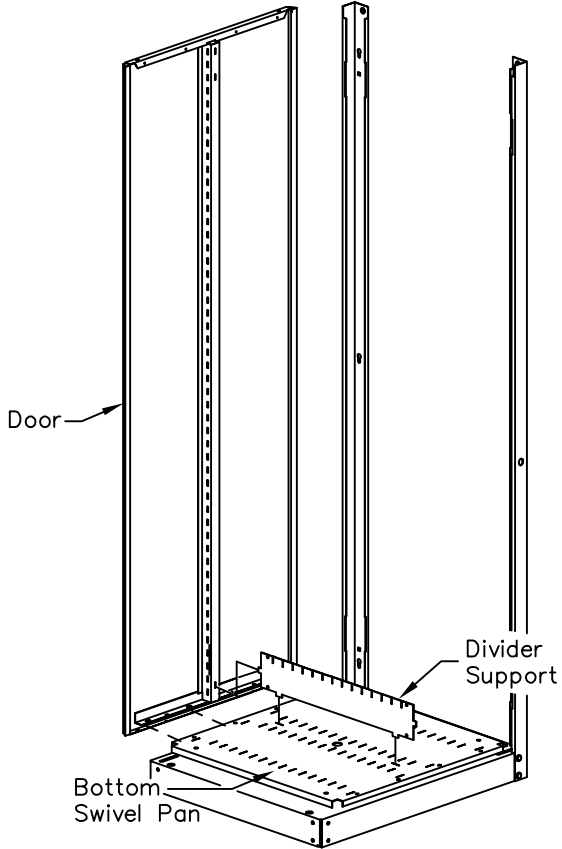

Fig 3.1 ((2) Vertical Supports not shown)

Secure doors to the bottom swivel pan using (4) 1/4-20x1/2" Pan Head Screws per door. (Fig. 3.2). Do not fully tighten screws.

(4) 1/4-20x1/2" Pan Head Screw per Door

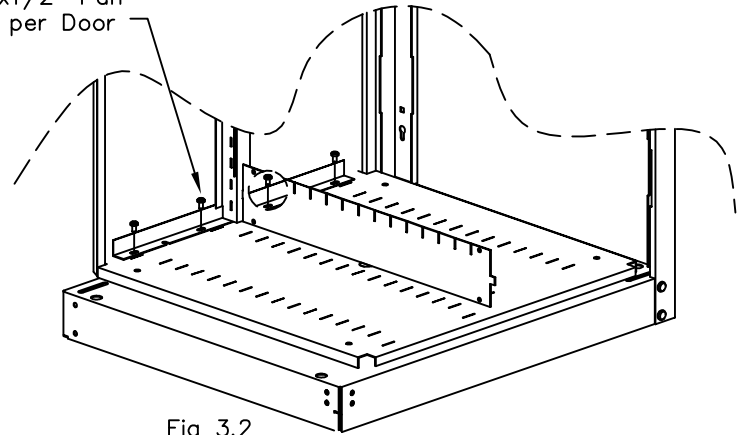

Fig 3.2

Insert the Cross Brace into the slots shown. The tabs on the cross brace should be pointing toward the floor. (Fig. 3.3) Slide the second door onto the bottom swivel pan. Verify that tab of divider support and tabs of cross brace are properly seated into the second door. (Fig. 3.4) Screw door into place using (4) 1/4-20x1/2" Pan Head Screws. Tighten all screws on doors.

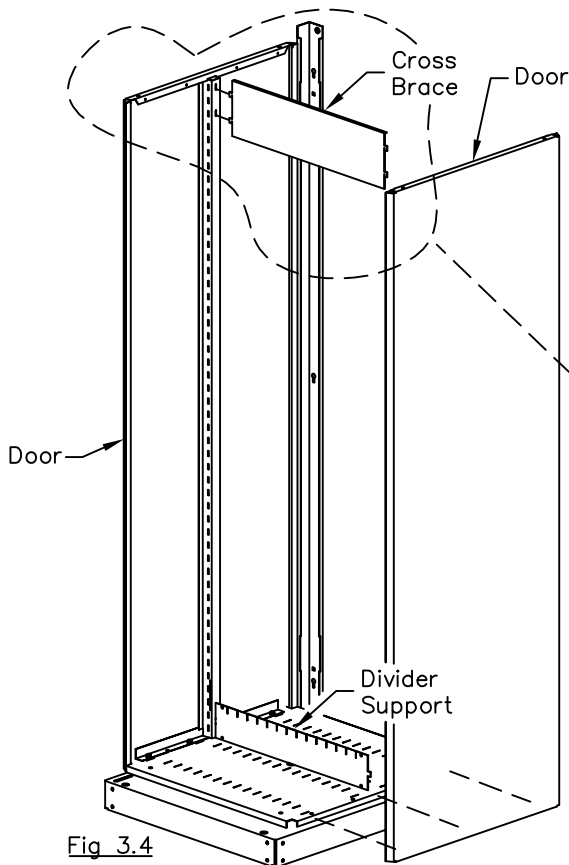

Fig 3.4

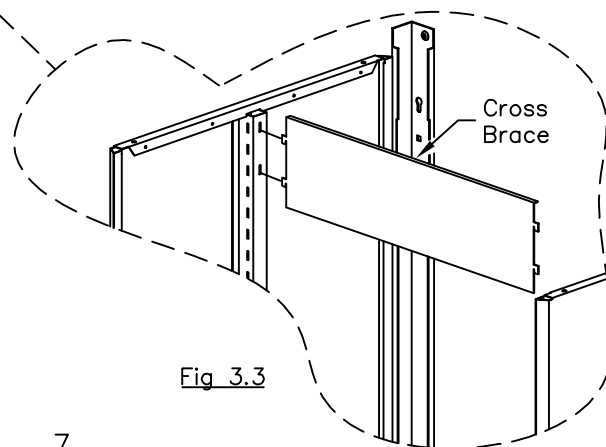
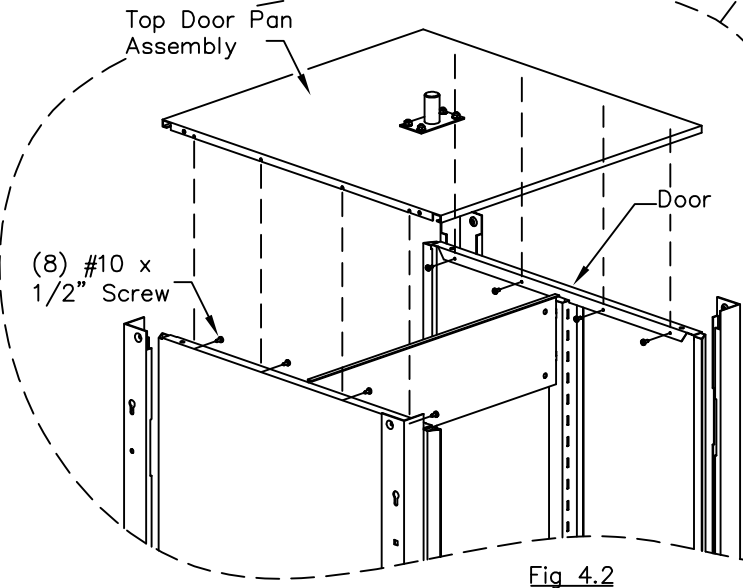
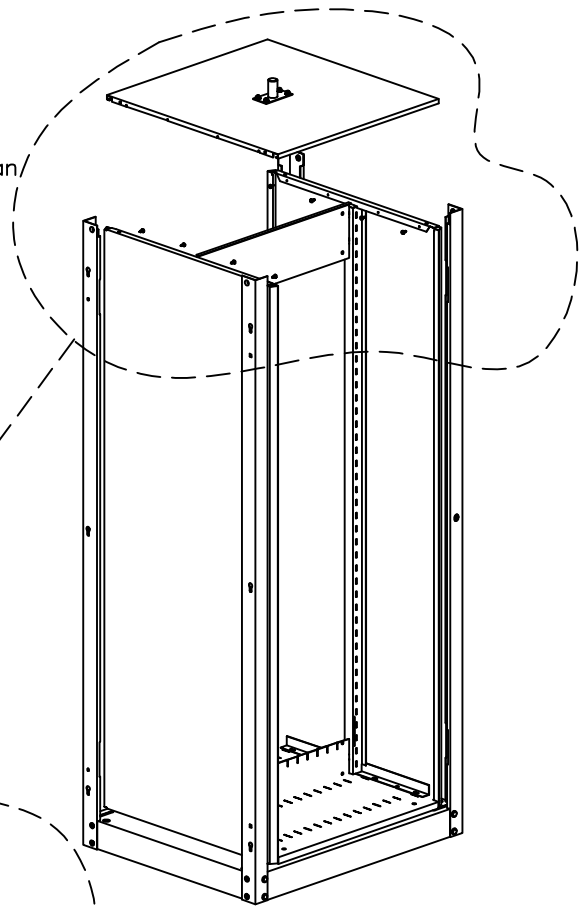
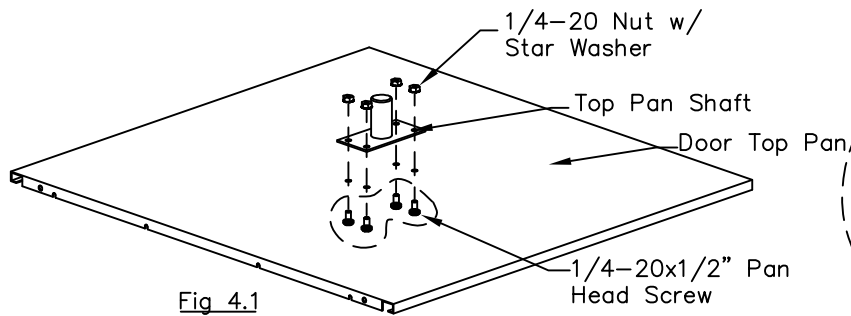

Fig 3.3

## 4. Top Door Pan Assembly

Mount the Top Pan Shaft to the Door Top Pan using (4) 1/4-20x1/2" Pan Head Screws and (4) 1/4-20 Nut with Star Washer. (Fig. 4.1)



Using (8) #10x1/2" screws, secure the top door pan assembly to the doors. Start the screws in the pre-drilled holes in top of the door, do not tighten screws.

Lower door top pan assembly onto screws. The shaft should be facing towards the ceiling. Once door top pan assembly is in the correct position, tighten all (8) #10x1/2" screws. (Fig. 4.2)

## 5. Top Pan Outer Shell

Secure the Top Pan Outer Shell to the (4) vertical supports by using (4) 1/4-20x1/2" Flat Head Screws & (4) 1/4-20 Nut w/ star washer. (Fig. 5.1) Flat Head Screws should be flush with the vertical supports. (Fig. 5.2)

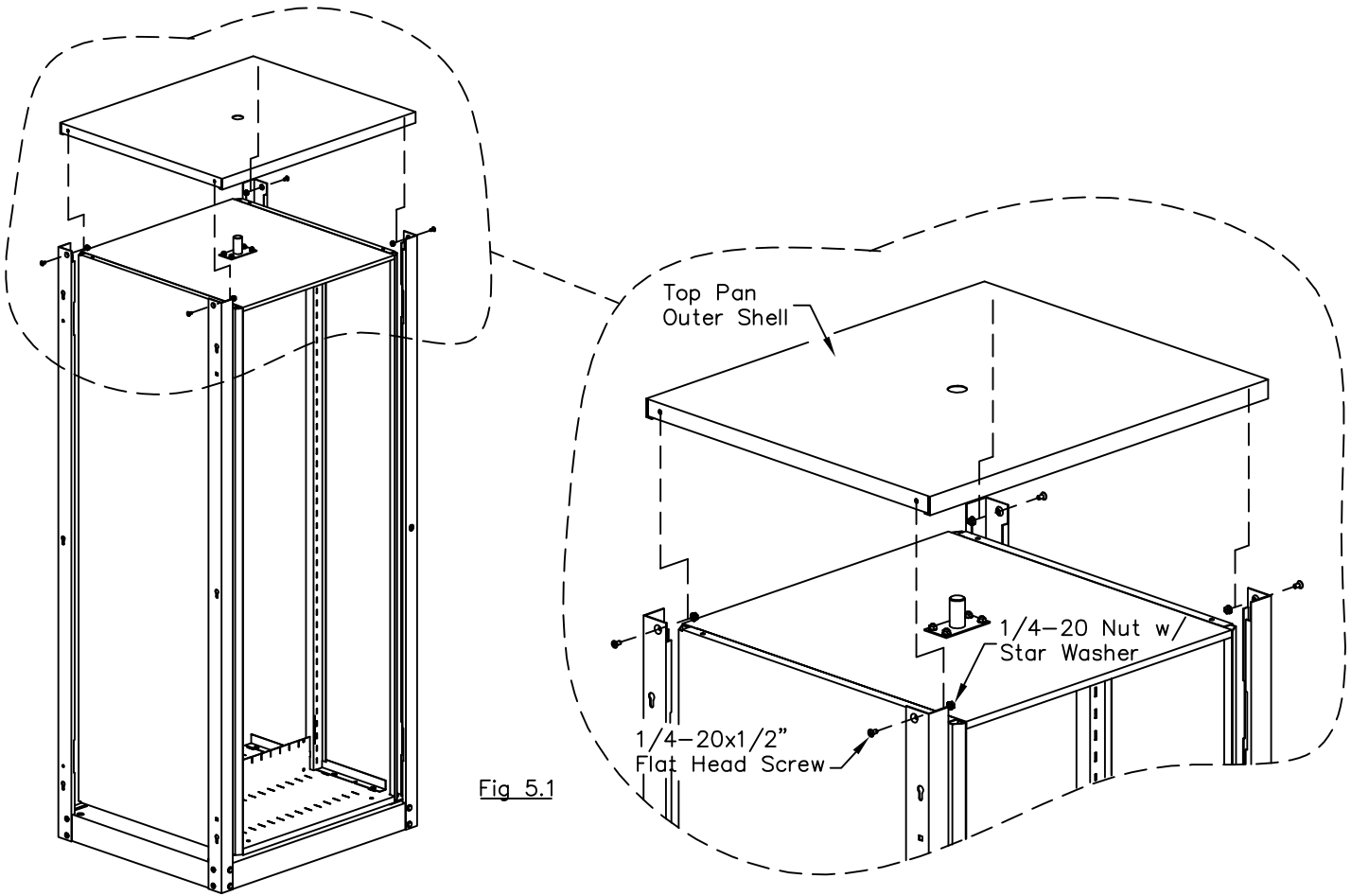

Slide the Bronze Bearing over the shaft and press the bearing into the hole in the top pan outer shell.

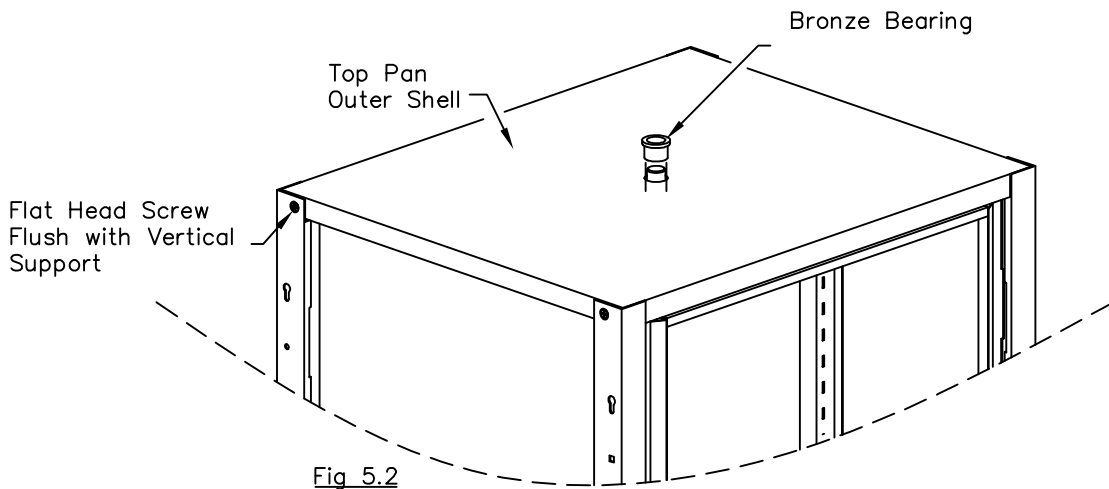

## 6. End Panel

Slide Arc units into the correct position. Place the back side of the letter units no closer than 5-1/4" from wall, legal units no closer than 6-1/2" from wall.

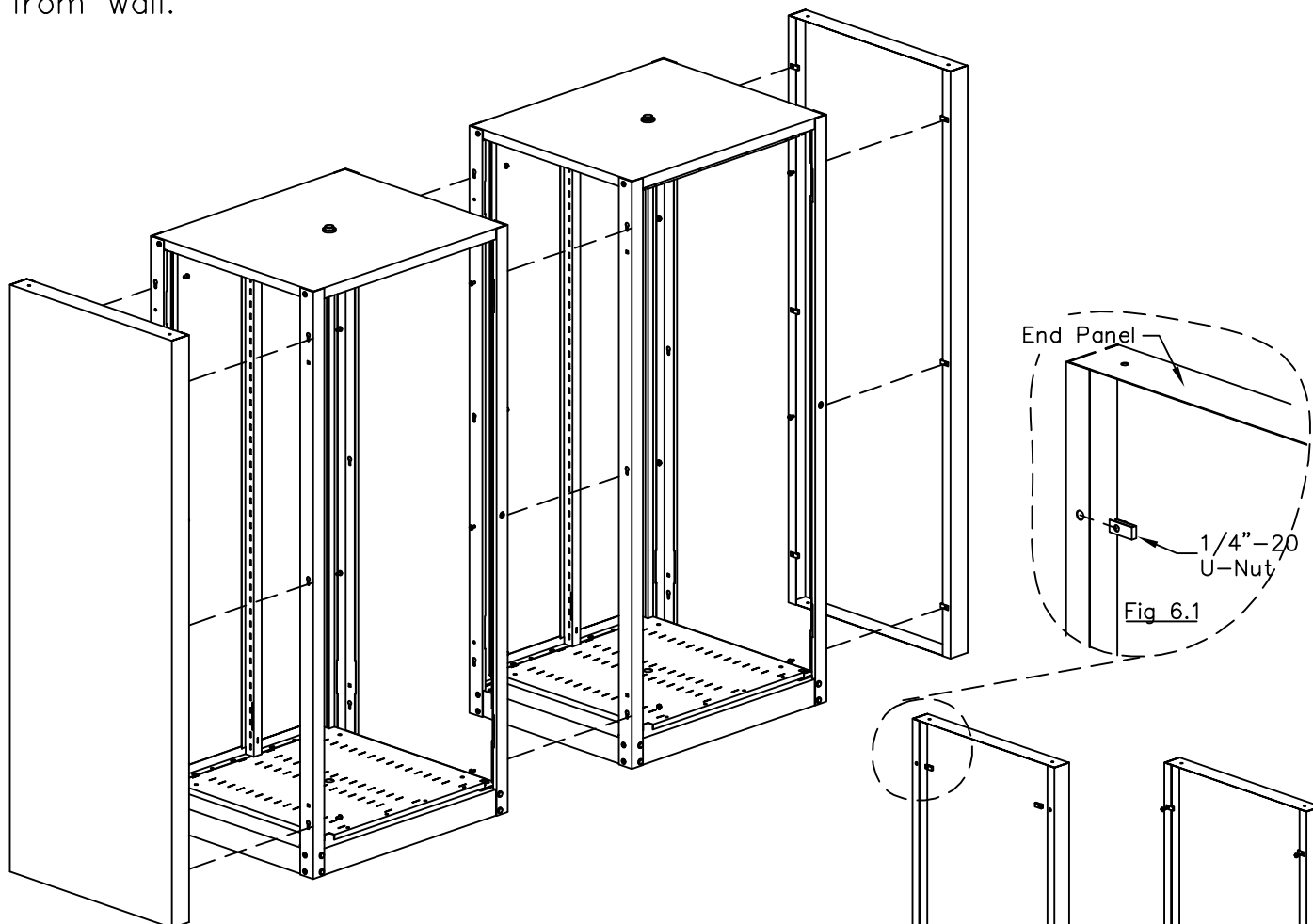

Install (6) 1/4-20 U-Nut into each end panel. U-nuts will snap into pre-drilled holes in the flanges of the end panels. (Fig. 6.1)

Start (6) 1/4-20x1/2 Pan Head screws into the U-Nut into each end panel. Leave screws loose enough to be able to hook into key holes on vertical supports. (Fig. 6.2)

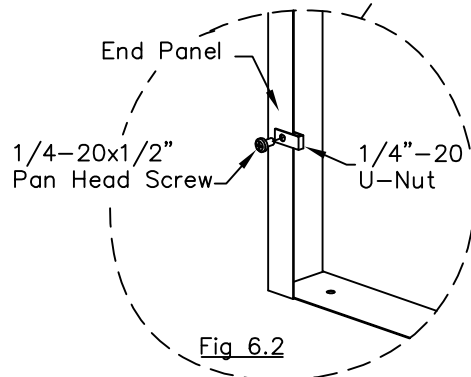

Lift the end panels and connect it onto the vertical supports. The (6) screws in each end panel will engage into the keyholes located on the vertical supports. (Fig. 6.3)

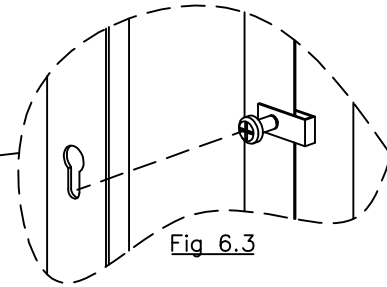
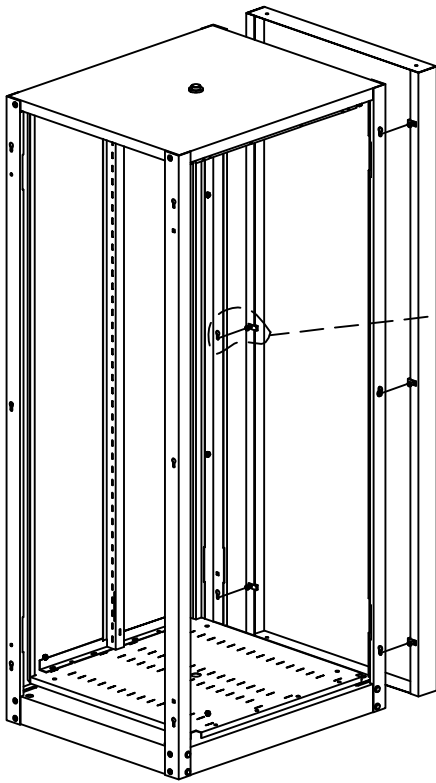

Fig. 6.3

Verify the end panels are flush with the vertical supports and tighten all (6) 1/4-20x1/2" Pan Head screws.

## 7. Connecting ARC Units

For connecting multiple units together, use (6) 1/4-20 Pan Head Screws and (6) 1/4-20 Nut w/ Star Washer to connect the vertical supports together. (Fig. 7.1) Verify that units are flush with one another.

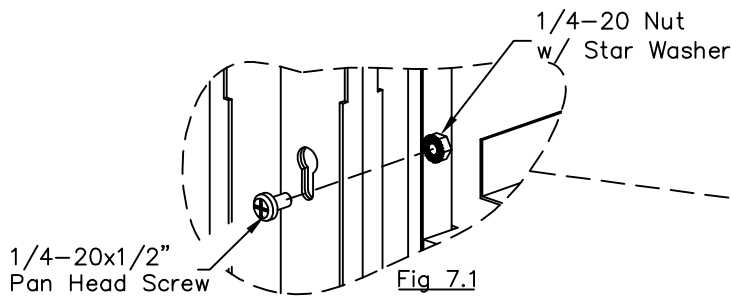
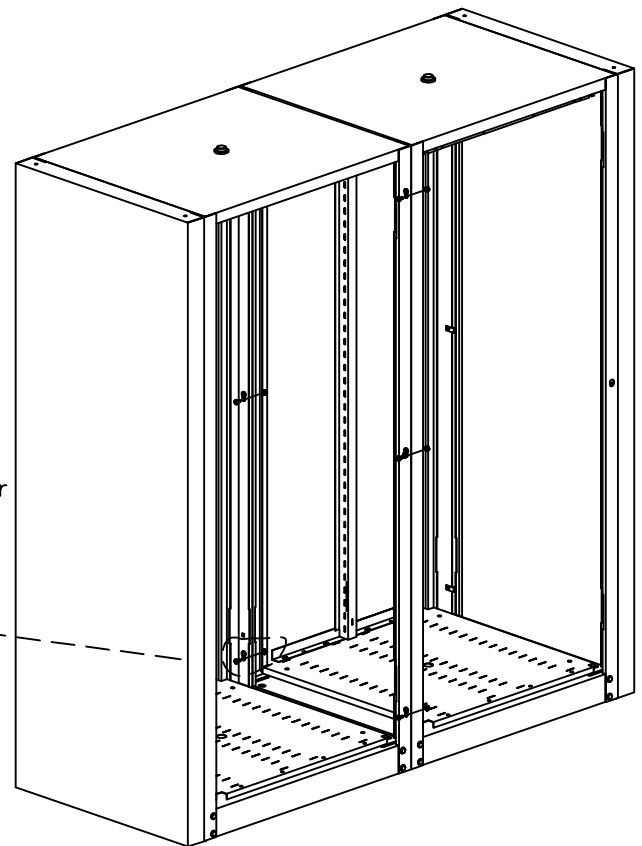
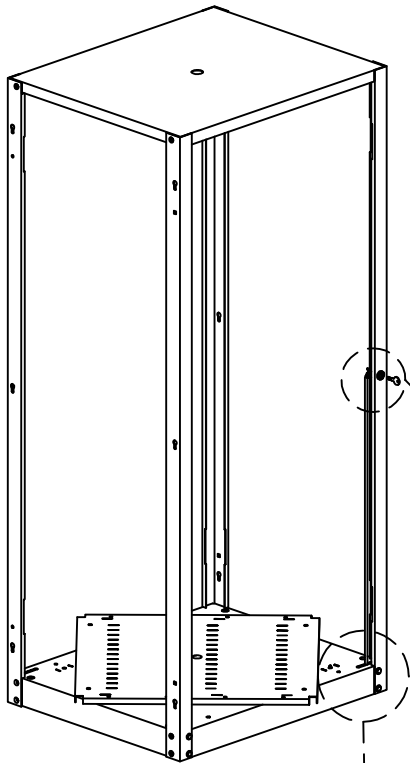

Fig. 7.1

## 8. Lock Installation

Insert lock into pre-drilled hole in Right Hand Vertical Support. The lock cam will rotate 180° from 6 to 12 o'clock. Secure lock in place with retainer nut (Fig. 8.1)



Rotate base approximately 45° to view lock rod holes. Insert hook end of lock rod into rectangular slot. Return lock rod to vertical position by inserting lock rod into the lock rod guide (Fig. 8.2). Slide other end of lock rod into pre-drilled hole in the lock cam and secure into place with a 1/16" x 1/2" long cotter pin (Fig. 8.1)

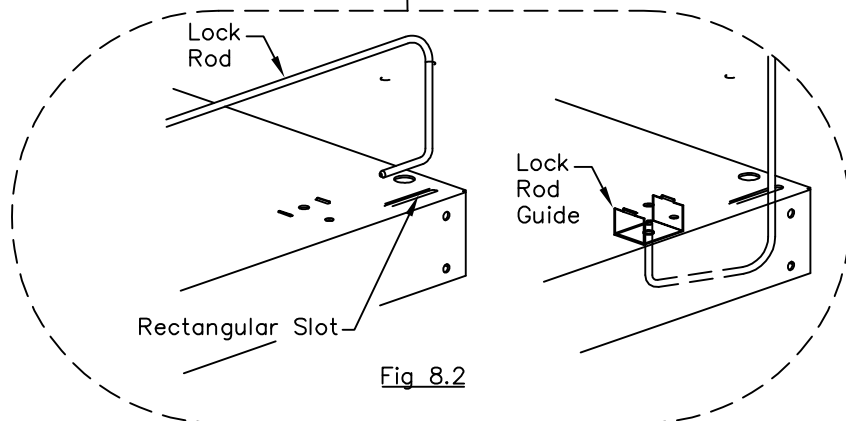
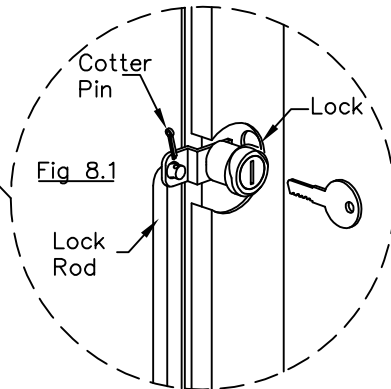

Note: The lock rod and lock can be installed at this time or after step 2 of installing the vertical supports.

## 9. Safety Strip Installation

(4) Safety strips are provided with each ARC unit. Press the safety strip onto each vertical support (Fig. 9.1).

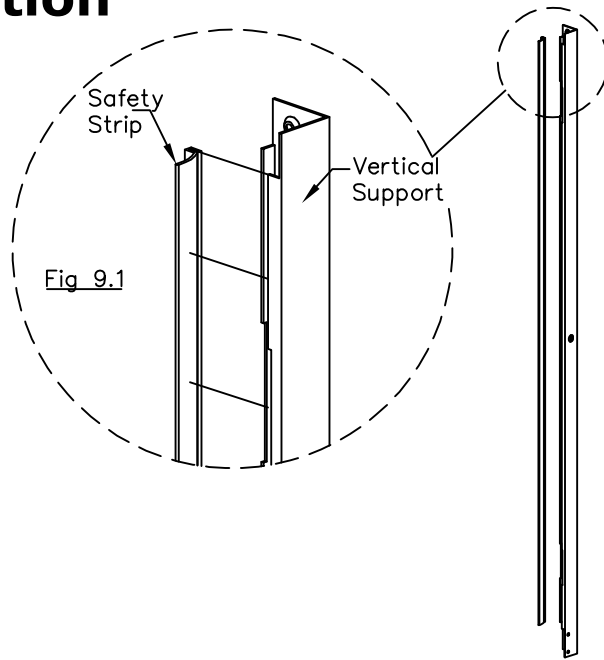
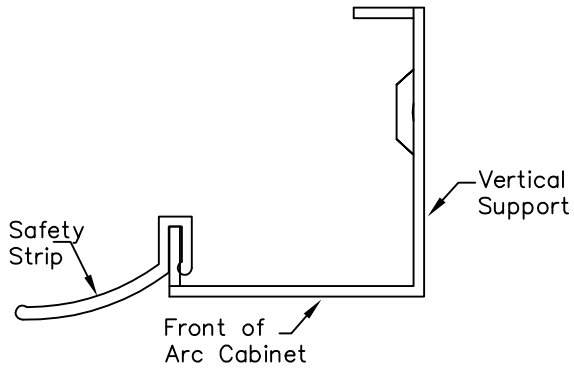

Top View of Assembled Safety Strip

## 10. Level Units

Using a 1/4" long neck socket and a bubble level, adjust (4) levelers on each base until units are level (Fig. 10.1). Leveling Access holes are located at the corners of the base unit.

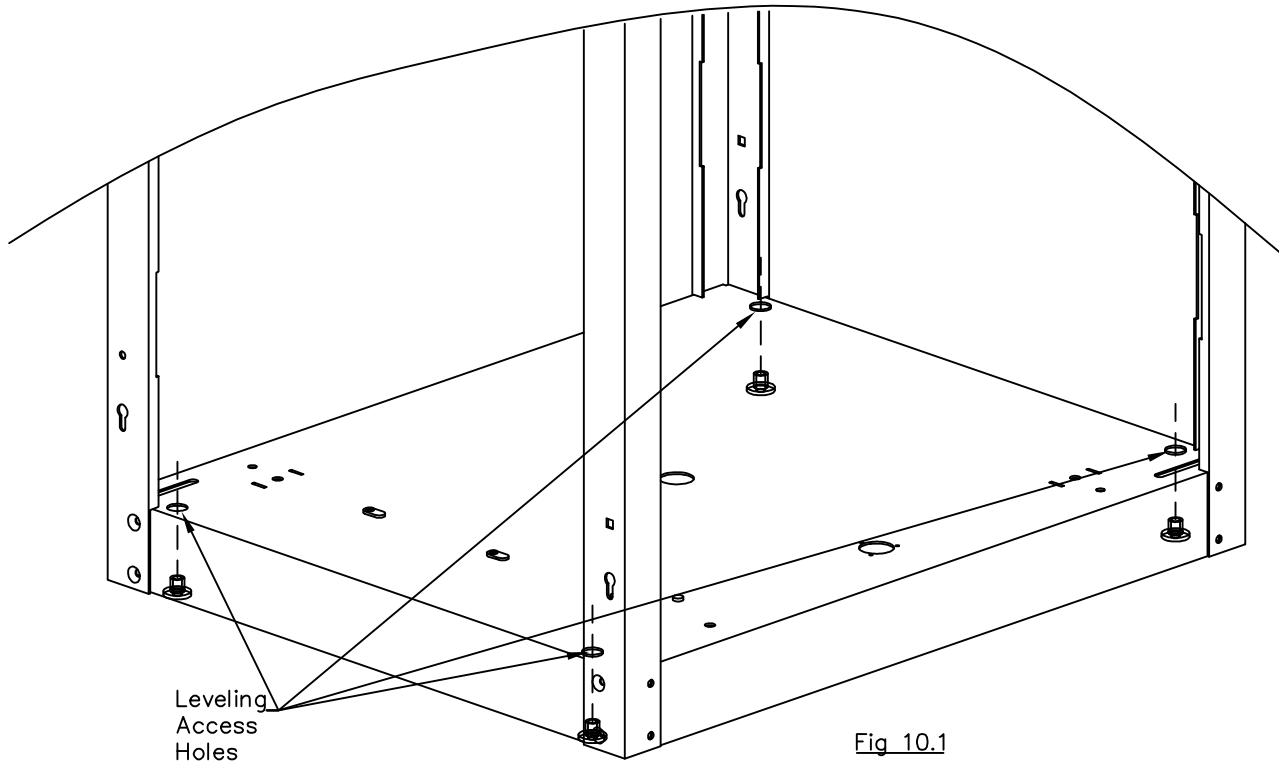

## **Customer Satisfaction**

*This order has been inspected for Quality and Quantity. If we have not satisfied this commitment to you, please call*

*Debbie Kellas  
Product Specialist*

*1-800-243-2263 (Ext. 122)*

*Thank you for your business.*

*Packer \_\_\_\_\_*

