

# MOUNTING TRIPOD

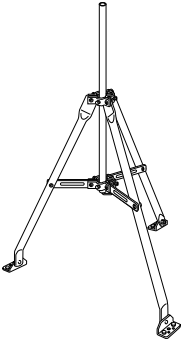

For use with Davis's Wireless, EZ-Mount, and Vantage Pro Weather Stations, the Mounting Tripod simplifies installation. The tripod supports the sensor array, and features an adjustable foot pad which enables mounting on any surface: flat, inclined, or level. The anemometer extension tube can be used to elevate the anemometer in installations where wind flow obstruction is a concern.

## COMPONENTS

The Mounting Tripod includes the following poles and mounting hardware. Please make sure you have everything you need before beginning.

### Poles

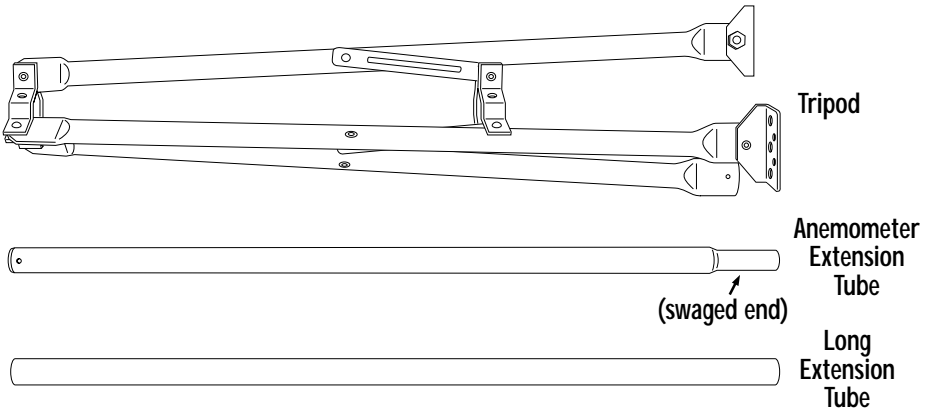

---

## Hardware

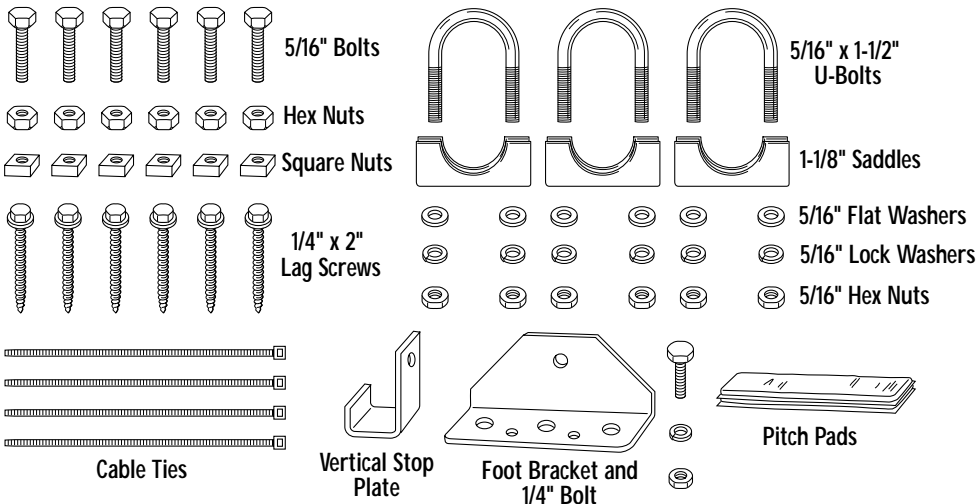

## TOOLS FOR SETUP

- ◆ Adjustable wrench
- ◆ Compass or local area map
- ◆ Drill with 3/16" or 13/64" (5 mm) bit for the 1/4" lag screws

## CONTENTS OF THIS MANUAL

- ◆ Tripod assembly, page 3
- ◆ Mounting the tripod, page 5
- ◆ Attaching the ISS to the anemometer extension tube, page 6
- ◆ Securing the ISS on the tripod, page 7
- ◆ Attaching the sensor array on EZ-Mount and Wireless systems, page 8
- ◆ Using the anemometer extension tube on EZ-Mount and Wireless, page 9

---

## TRIPOD ASSEMBLY

Follow the instructions below to assemble the tripod.

Assemble nuts and bolts  
in Tripod brackets.  
Do not tighten.

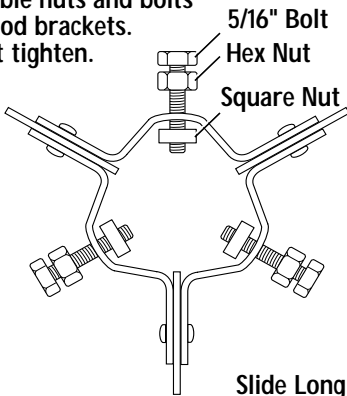

Use Vertical Stop Plate  
on one of the lower  
bracket bolts.

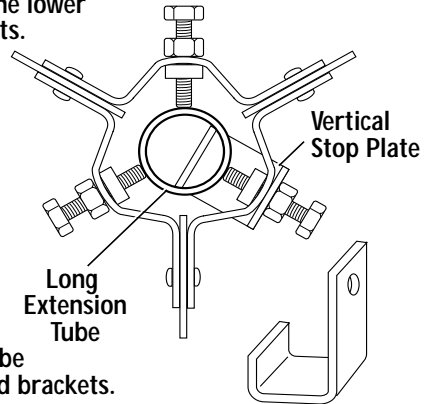

Slide Long Extension Tube  
through center of Tripod brackets.  
Tighten nuts and bolts.

1. Unfold the tripod so the two foot pads which come pre-installed on the tripod legs are flat on the ground.
2. Thread a hex nut almost all the way onto all six of the 5/16" bolts.
3. Insert one of the 5/16" bolts into the hole in vertical stop plate.
4. Insert the 5/16" bolt with vertical stop plate into one of the holes in the tripod's lower bracket and thread a square nut onto the end of the bolt, on the inside of the bracket. Do not thread the square nut too far up the bolt.
5. Repeat this procedure for the remaining 5/16" bolts. Place them into the holes in both the top and bottom tripod brackets, threading a square nut on the end of each bolt. Do not thread the square nuts too far up the bolts.
6. Insert the long extension tube into the tripod, sliding it through the brackets. The vertical stop plate should keep the tube from sliding all the way through.
7. Secure the extension tube by tightening the square and hex nuts on the 5/16" bolts until the bolts hold the tube in place securely.

- 
8. Attach the foot bracket to the tripod leg as shown below.  
Apply pitch pads to the bottom of the foot bracket and the two foot brackets that come pre-installed on the tripod.

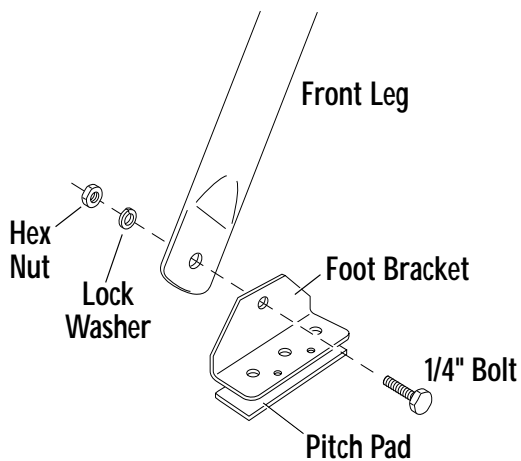

---

## MOUNTING THE TRIPOD

Mount the tripod with long extension tube on the desired surface, as shown below. On the following pages are instructions for securing your sensor array or ISS onto the long extension tube.

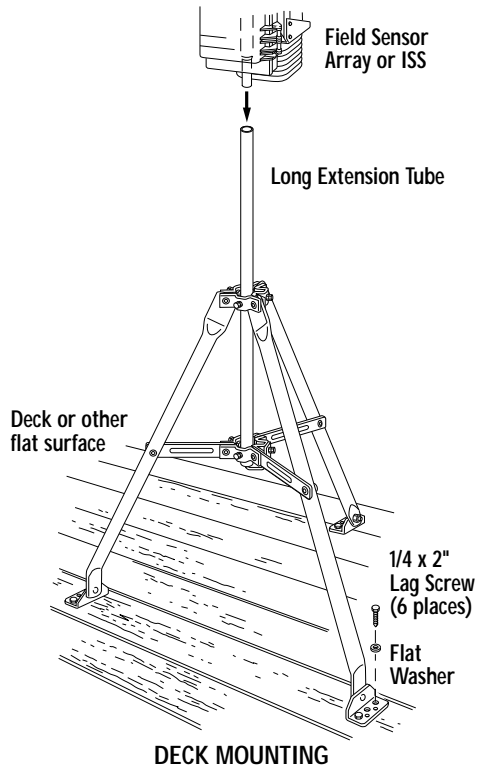
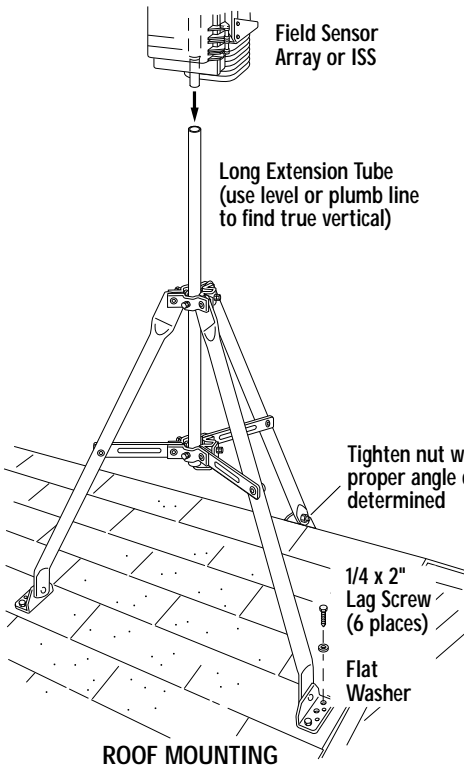

⚡ **CAUTION:** Any metal object may attract a lightning strike, including your weather station or tripod. If lightning strikes your station or strikes somewhere nearby, the station's internal electronics may suffer anywhere between little to extensive damage. The station itself has been designed with considerable surge protection, but to safeguard nearby equipment and structures, we recommend following local recommendations on properly grounding your installation. For more information, contact your local lightning protection authority and/or refer to the following articles:

- ◆ MIL-HDBK-419A: Grounding, Bonding, and Shielding for Electronic Equipments and Facilities, 29 Dec 1987.
- ◆ National Fire Protection Association, 1997: Standard for Installation of Lightning Protection Systems, 1997 ANSI/NFPA 780, National Fire Protection Association, Quincy, MA.
- ◆ NEC, National Electrical Code, 1996 Edition: National Fire Protection Information, Quincy, MA.

---

## ATTACHING THE ISS TO THE ANEMOMETER EXTENSION TUBE

For Vantage Pro, the anemometer extension tube provided as part of the mounting tripod will be used to support the ISS, which does not come on its own pole. You can mount your ISS on this tube with both sides together or separate. For better access to the hardware securing the rain collector side, remove the rain collector cone by rotating it counter-clockwise and lifting it off.

Mount your ISS on the anemometer extension tube as shown below, in either **Configuration A** or **Configuration B**. Make sure the swaged end of the tube is pointing downward as you secure the ISS to it.

### Configuration A — Both Sides Together

Remember when mounting both sides together that whichever side of the ISS is mounted first, the U-bolt from the opposite side ALSO must be placed around the pole before you tighten anything. (If it is not, there is no way to slide it in later.)

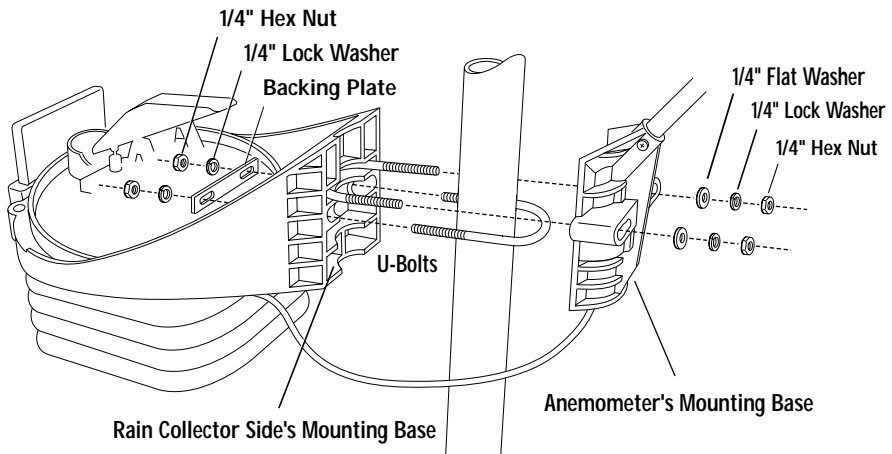

## Configuration B — Anemometer Above the Rain Collector Side

Secure the rain collector side to the anemometer extension tube as shown in the illustration on the left. Then mount the anemometer above it as shown on the right.

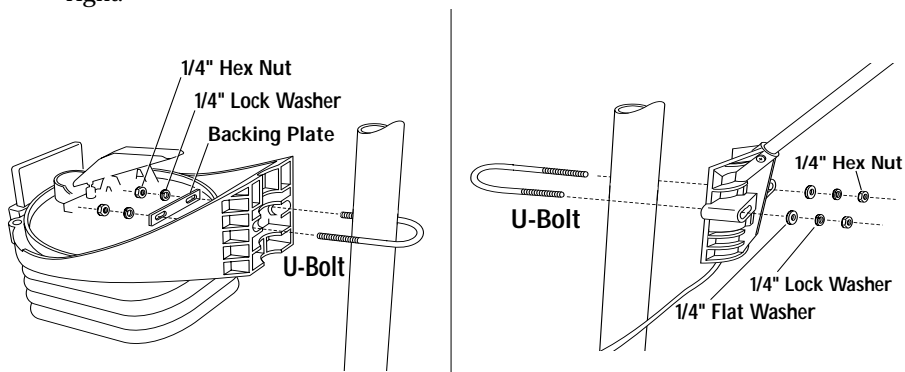

## SECURING THE ISS ON THE TRIPOD

Now the ISS is firmly attached to the anemometer extension tube.

1. Insert the swaged end of the anemometer extension tube down into the long extension tube in tripod.
2. Consulting a compass or local map, turn assembly until the anemometer arm points directly north.
3. Place the U-bolt provided with the tripod around the tubes where they overlap. Secure saddle onto U-bolt with flat washers, lock washers, and hex nuts as shown.
4. Tighten the hex nuts quite firmly, until the U-bolt begins to dent the tubing slightly.

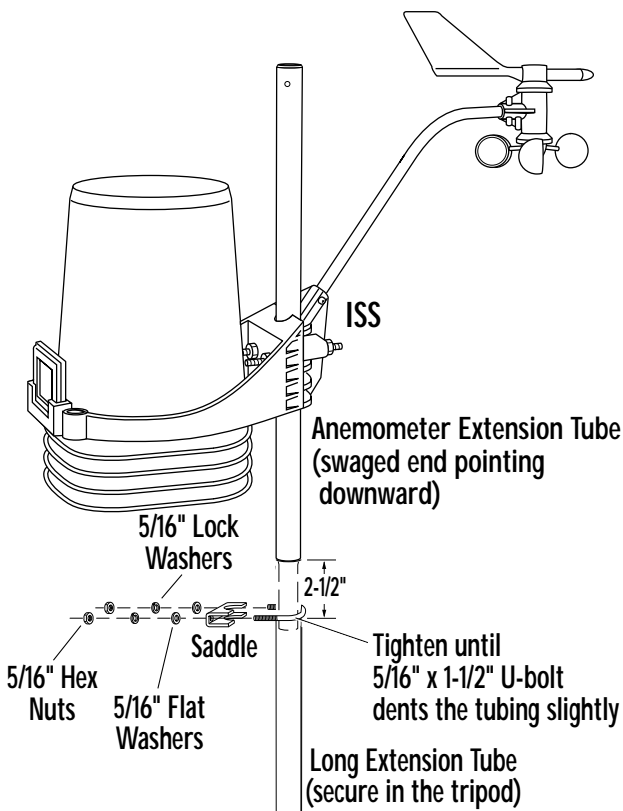

**NOTE:** For Vantage Pro, the anemometer arm must point northward when mounted, or you will have to re-orient the wind vane. (Re-orienting instructions are located in **ISS Installation Manual: Appendix C.**)

## ATTACHING SENSOR ARRAY ON EZ-MOUNT AND WIRELESS SYSTEMS

Insert the sensor array pole into the top of the long extension tube and secure using U-bolts and saddles provided with the mounting tripod.

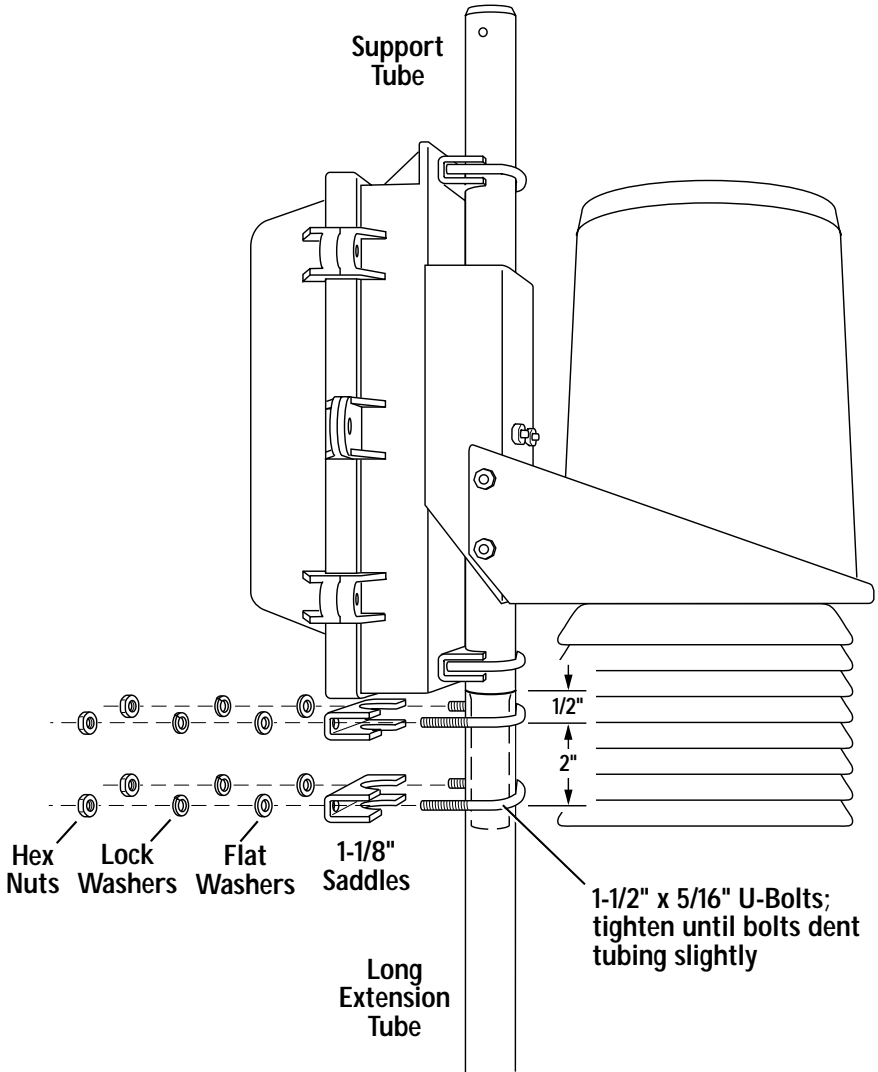

# USING ANEMOMETER EXTENSION TUBE ON EZ-MOUNT AND WIRELESS SYSTEMS

If you need the anemometer mounted higher, install the anemometer extension tube as shown below.

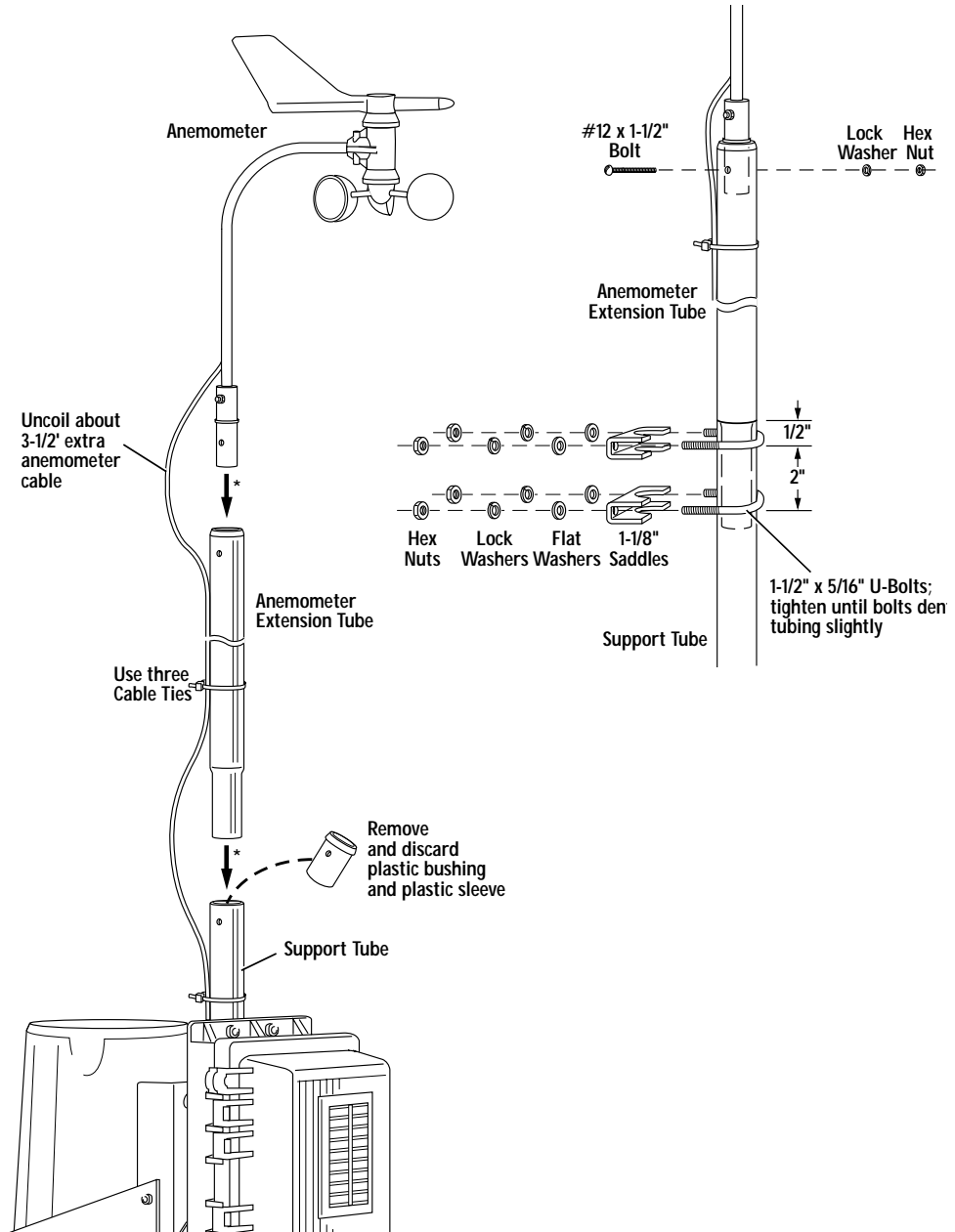

---

Product Numbers: 7716  
Davis Instruments Part Number: 7395.299  
Mounting Tripod  
Rev. D Manual (1/25/01)

This product complies with the essential protection requirements of the EC EMC Directive 89/336/EC.

© Davis Instruments Corp. 2000. All rights reserved.



3465 Diablo Avenue, Hayward, CA 94545-2778

510-732-9229 • Fax: 510-732-9118

E-mail: [info@davisnet.com](mailto:info@davisnet.com) • [www.davisnet.com](http://www.davisnet.com)