

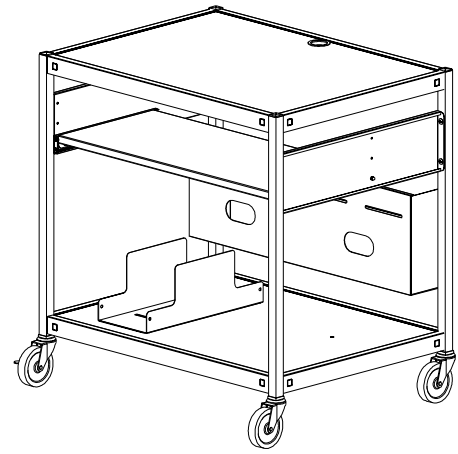

# BRETFORD

## EC4000 / EC4000FF MOBILE COMPUTER WORKSTATION WITH CPU HOLDER Assembly Instructions



### PARTS LIST

Qty	Part#	Description	Ref
1	022-2006	Top Shelf w/ grommet hole	AA
1	010-4513	Slide Out Shelf	BB
1	010-3264	Bottom Shelf w/ mounting holes for CPU Brackets	CC
2	010-4506	Shelf Support Brackets	DD
1	022-2009	Right Front Leg	EE
1	022-2008	Left Front Leg	FF
1	022-2011	Right Rear Leg	GG
1	022-2010	Left Rear Leg	HH
1	022-2007	Cord Bin	II
2	010-3058	Side Bracket, CPU	JJ
2	015-0002	4" Casters w/o Lock	
2	015-0003	4" Casters w/ Lock	
1	030-1191	14" Full Extension Slide	
1	CFPS	Electrical Unit - EC4000FF ONLY	

### HARDWARE LIST

Qty	Part#	Description
16	030-0300-21S	5/8" Square Head Bolt
16	030-0002	5/16-18 Hex Serrated Nut
12	030-0304	1/4-20 x 5/8" Combo Screw
10	030-1228	1/4" #8-32 Truss Screws
4	030-1203	#8-32 Acorn Nuts
2	030-0272	1/4-20 x 1/2" Carriage Bolt
2	030-0256	1/4-20 Flange Nut
2	031-1822	Velcro-Hook
2	031-1823	Velcro-Loop
6**	02236	8-32 Flange Whiz Lock-Nut
1	010-1106	Hex Wrench
**2	02236	8-32 Flange Whiz Lock-Nut
2	030-0302	8-32 x 3/8" Combo Truss Screws

\*\*Use these screws instead of the ones supplied with the CFPS unit. A longer length screw is required for this cart.

### TOOLS REQUIRED

- Hex Wrench (Provided)
- Phillips Screwdriver
- Rubber Mallet

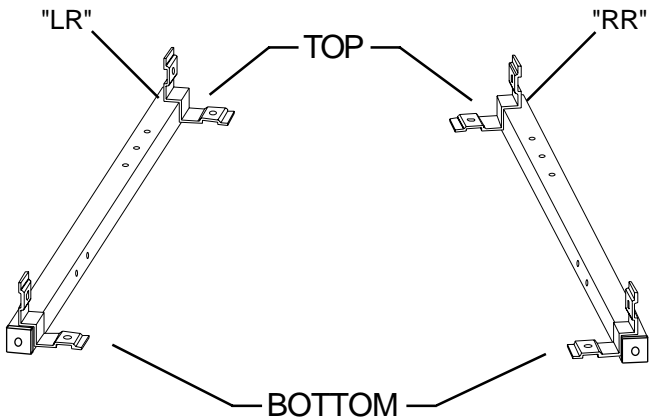
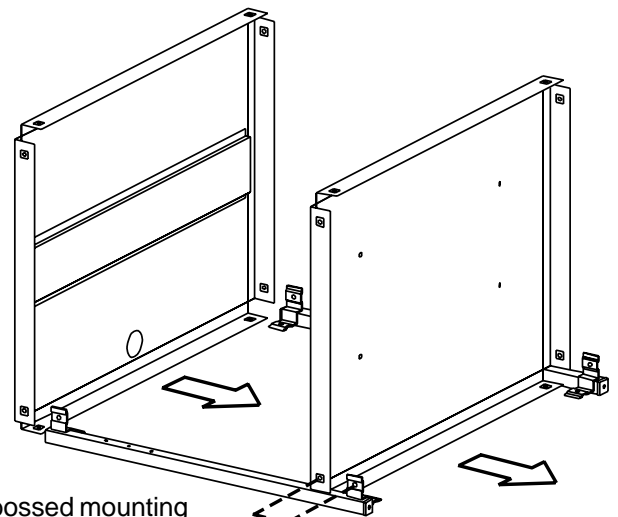

FIGURE 1



Align shelf embossed mounting hole with leg mounting bracket. 2 corners each shelf.

FIGURE 2

### STEP 1

Lay the rear legs on a carpeted surface (they are stamped "LR" and "RR") with the three top holes facing up and the bracket facing up as shown in **Figure 1**. Slide the top shelf (with hole at rear) and bottom shelf (with 4 square holes toward front) onto the legs so that the brackets are inside the shelves (**see Figure 2**).

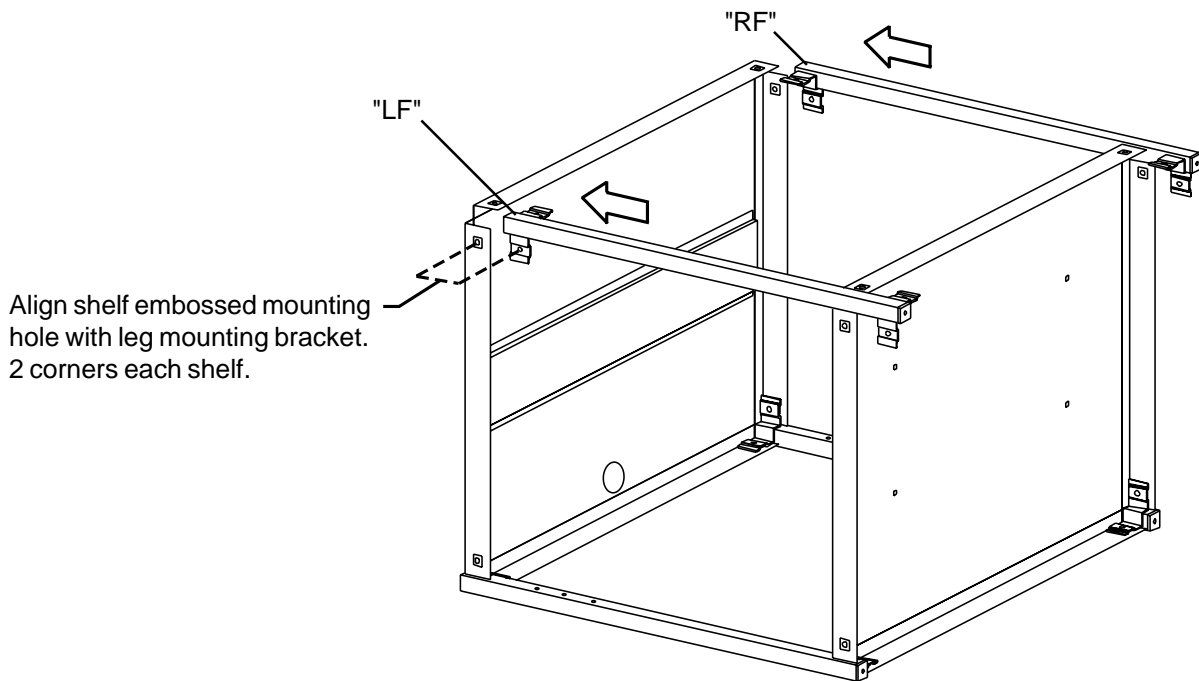

Align shelf embossed mounting hole with leg mounting bracket. 2 corners each shelf.

### STEP 2

Slide the front legs (they are stamped "LF" and "RF") onto the shelves so that the brackets are inside the shelves.

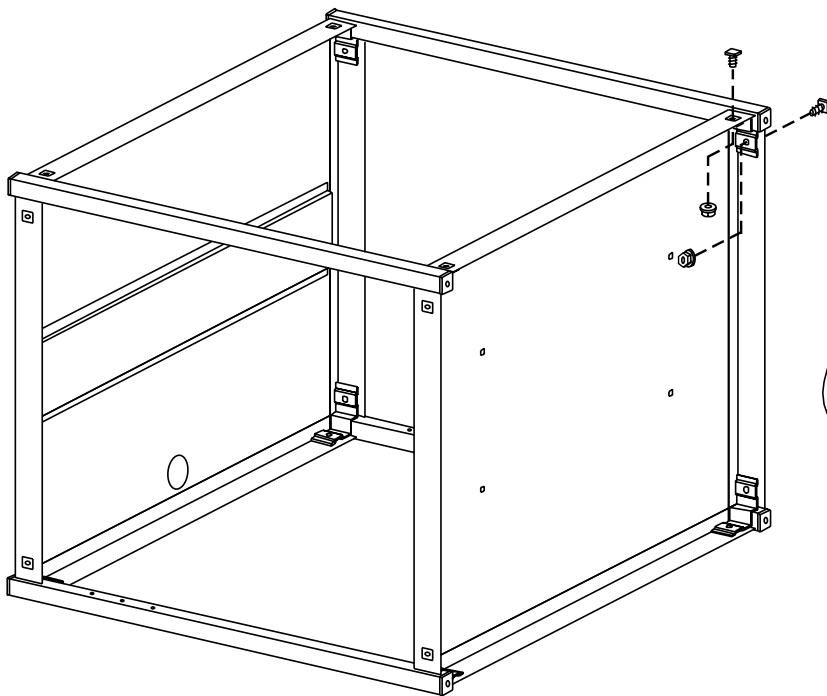

### STEP 3

Secure shelves and legs together with bolts (AA) and nuts (BB) in each corner as shown.

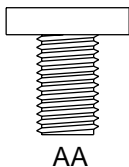

AA

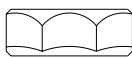

BB

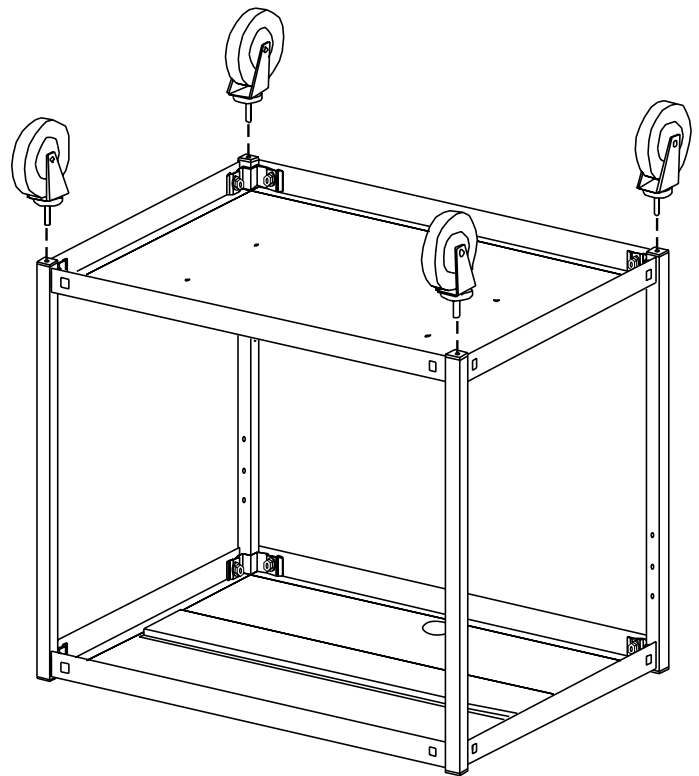

### STEP 4

Insert each caster into the bottom of each leg. If caster does not insert easily, use a rubber mallet to tap caster in place. Once casters are **SECURELY** in place, stand unit upright.

SHELF SUPPORT BRACKET

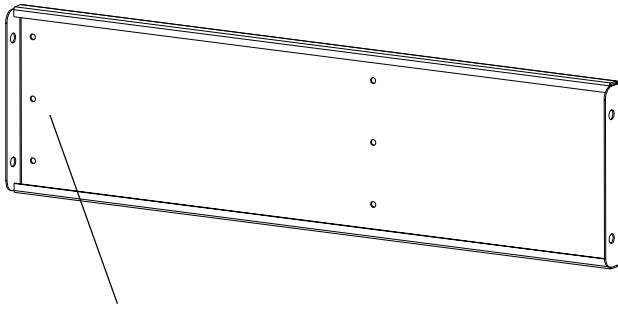

THESE HOLES MUST FACE FRONT  
EDGE OF CART. (SIDE OPPOSITE  
THE GROMMET)

DETAIL 'A'

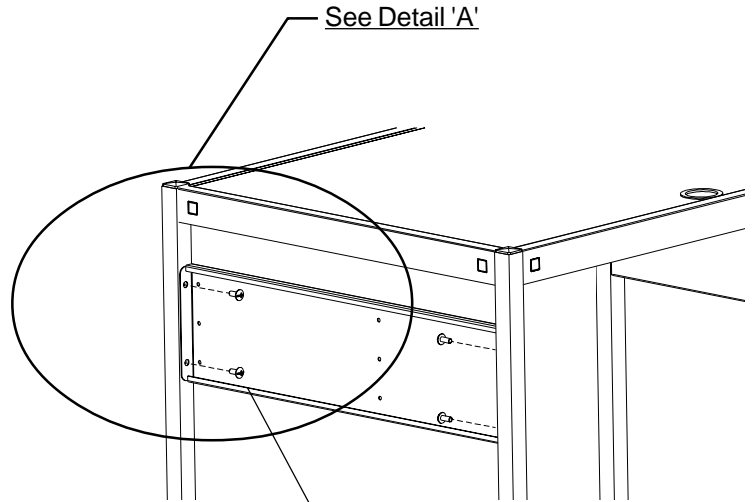

FIGURE 3

CC

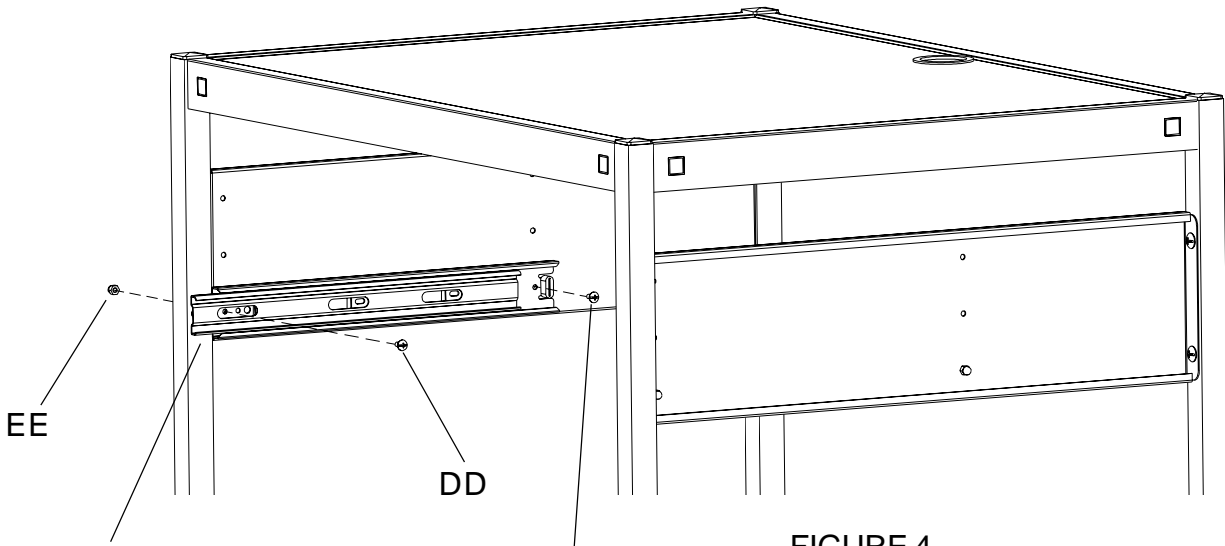

FIGURE 4

To access the correct holes,  
slide inner piece out slightly.

Attach rear screw  
& nut FIRST.

**STEP 5**

Attach shelf support brackets to upper portion of rear legs with screws (CC) as shown in **FIGURE 3**. Refer to **Detail 'A'** for correct position of bracket. Then separate each slide and attach the outer section to the inside of each shelf support bracket with screws (DD) and nuts (EE) as shown in **FIGURE 4**. **NOTE: Attach rear screw and nut first.**

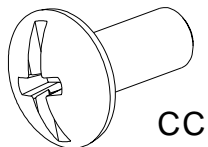

CC

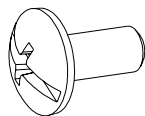

DD

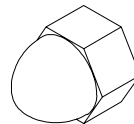

EE

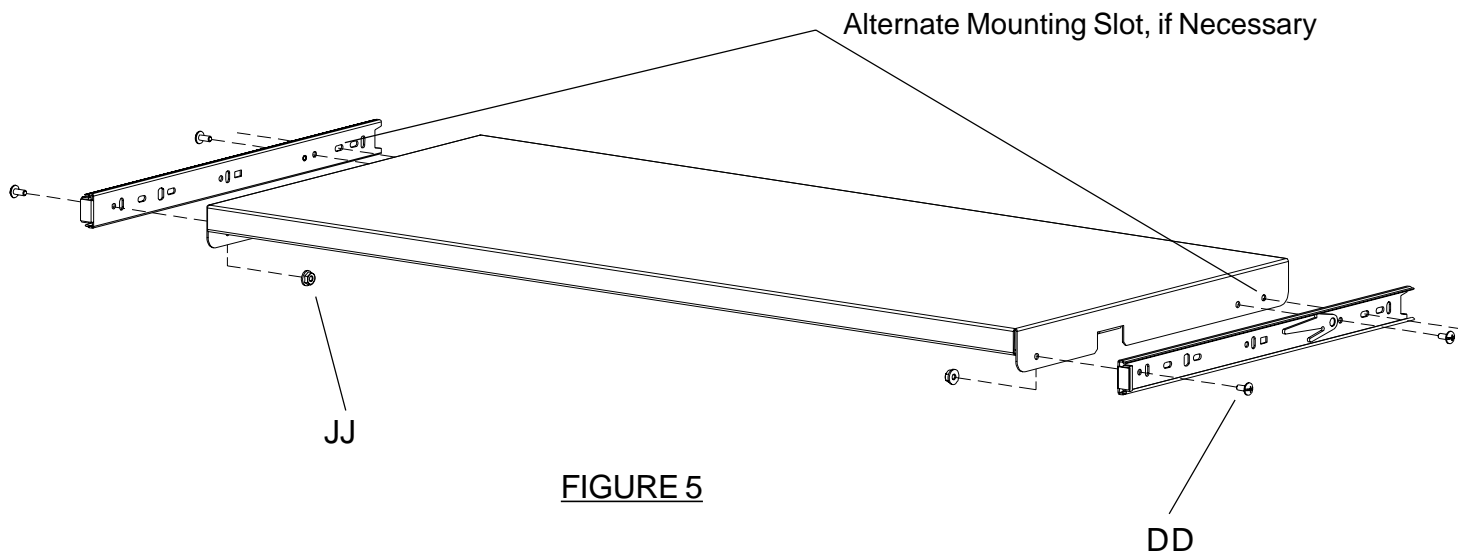

**FIGURE 5**

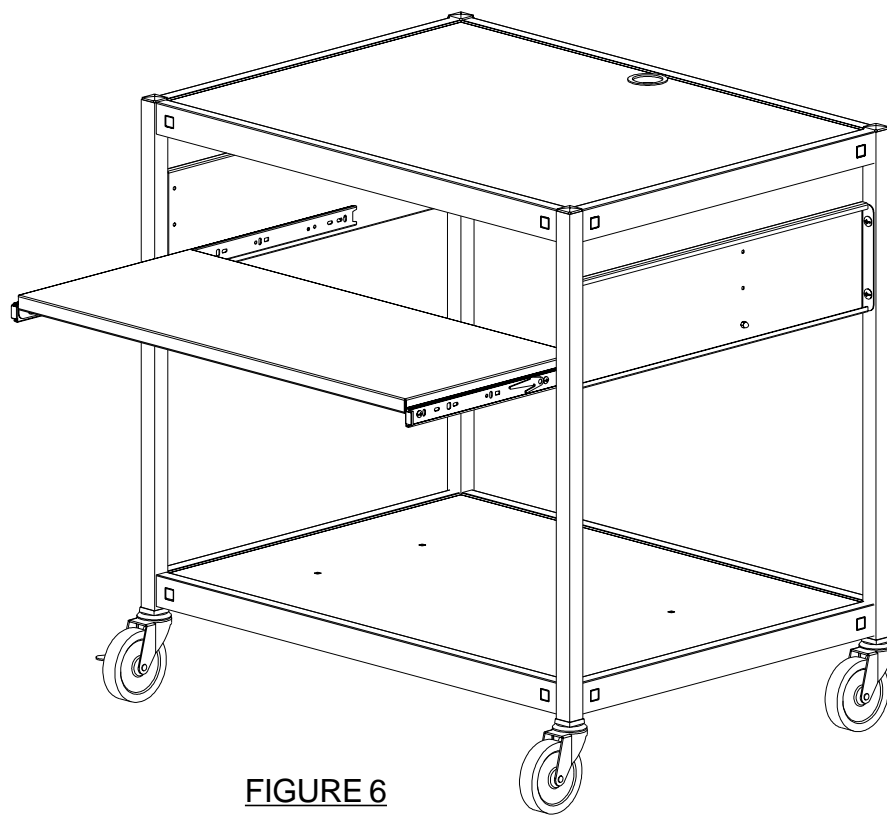

**FIGURE 6**

**STEP 6**

Attach the remaining slide pieces to the pull out shelf with screws (DD) and nuts (JJ) as shown in **FIGURE 5**. Then slide shelf into cart as shown in **FIGURE 6**.



JJ

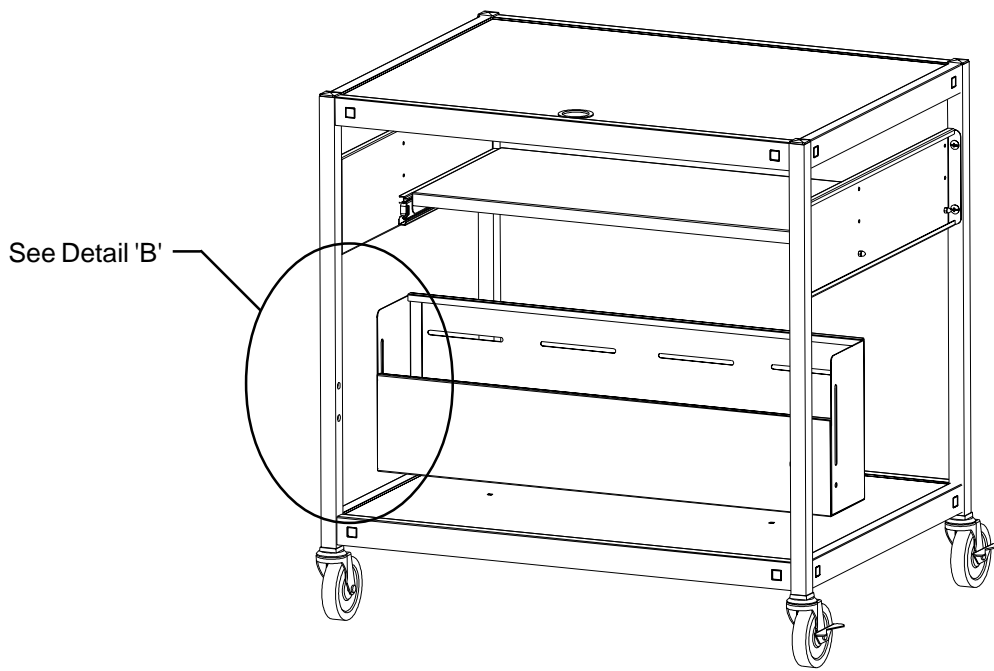

REAR VIEW

**STEP 7**

Slide the cord bin between the rear legs and align slotted holes of the cord bin sides with the (2) mounting holes of the legs. Position the cord bin per Detail 'B' to obtain desired height and install four screws (CC).

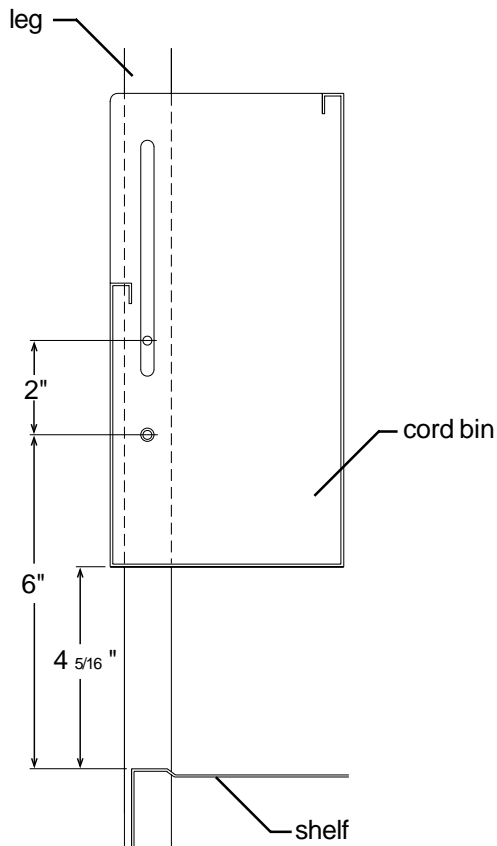

Position #1 (fixed)

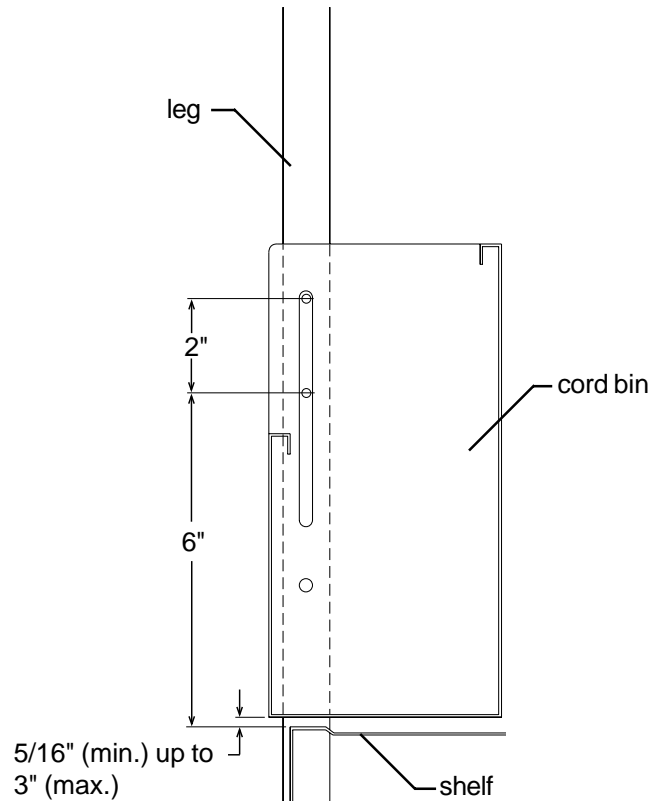

Position #2 (adjustable)

**Detail 'B'**

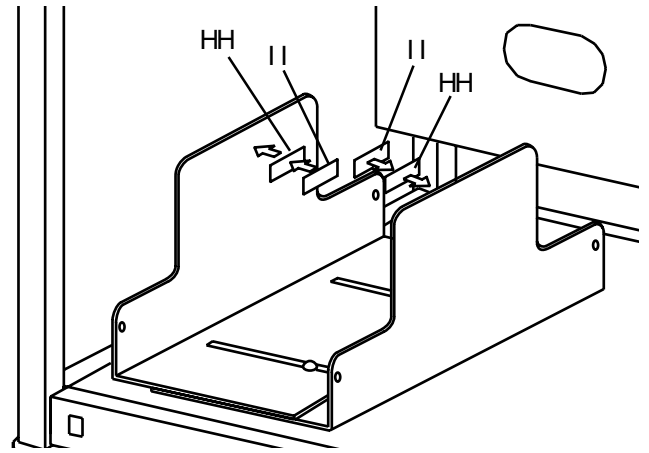
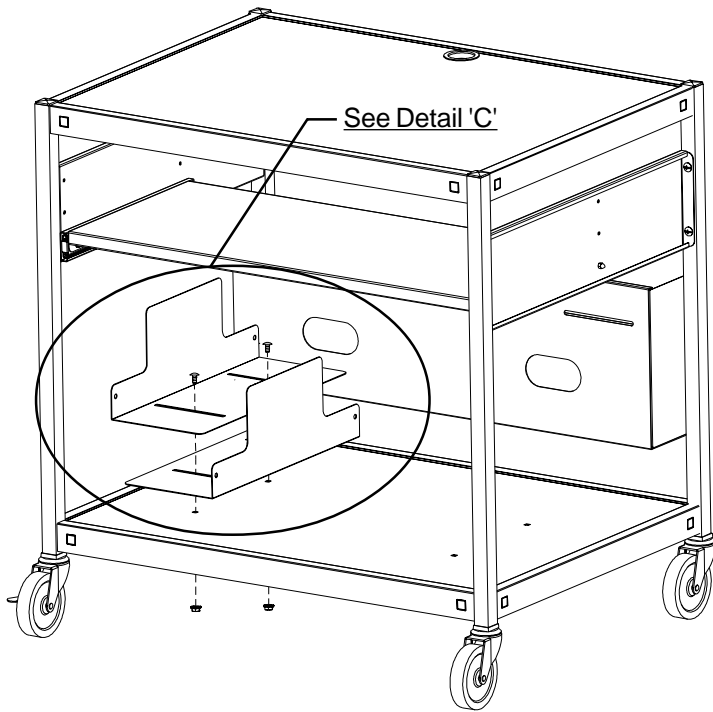

**Detail 'C'**

**STEP 8**

Install two CPU side brackets by placing one over the other and aligning them over the square mounting holes in the bottom shelf. You can place the CPU brackets on the left or right hand side (see detail below). Install carriage bolts (FF) and flange nuts (GG). Apply Velcro (HH & II) per Detail 'C'.

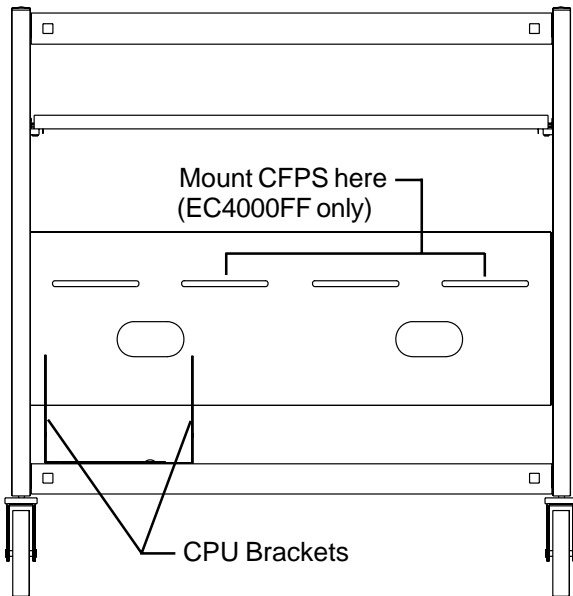

**Front View  
Left Hand  
Mounting**

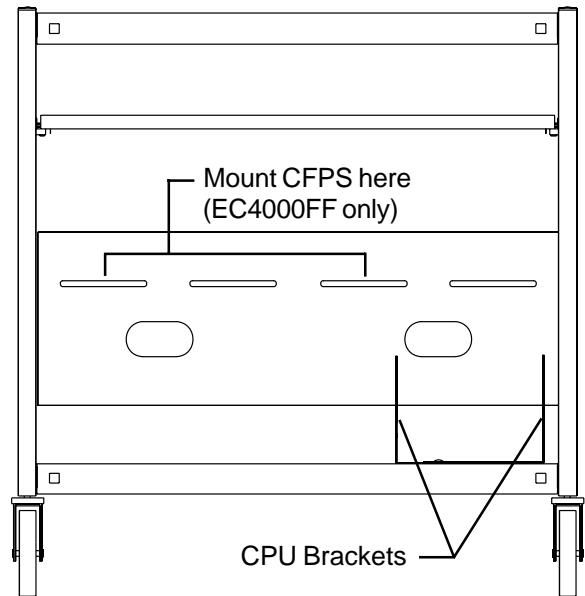

**Front View  
Right Hand  
Mounting**

**Bretford**  
11000 Seymour Avenue  
Franklin Park, IL 60131  
TEL: 847.678.2545  
800.521.9614  
FAX: 847.678.0852  
800.343.1779

**Bretford Ltd.**  
2 Etongate  
110 Windsor Road  
Slough, Berkshire SL1 2JA England  
TEL: 01753 216531  
FAX: 01753 539478