

**Z-Line Standard Boltless Rack  
Installation Instructions**

Tennsco Corp., Dickson, TN 37056-1888 • (615) 446-8000

**RETAIN INSTRUCTIONS FOR FUTURE REFERENCE!**

Congratulations on your purchase of Z-Line Standard Boltless Rack from **Tennsco!** Z-Line's interlocking keyhole design not only makes installation fast and easy but eliminates the need for clips, gussets, sway braces or other hardware commonly used in conventional shelving. This allows completely free access to your stored materials from all sides of the unit.

Z-Line Boltless Rack is available in both standard- and heavy-duty strengths, in a variety of heights, widths and depths to fit virtually any storage application. Adding an extra shelf is quick and easy. And starter and adder units allow for joining shelving units together .



**GENERAL SAFETY INFORMATION**

Some parts may have sharp edges. CARE must be taken when handling the pieces to avoid injury. For safety, wear a pair of work gloves when assembling or performing any maintenance on shelving.

**SHELF LOAD CAPACITIES**

Unit Width	Load Capacity, No Deck Support	Load Capacity, With Deck Support
48"	1750 lbs.	2250 lbs.
72"	1250 lbs.	1750 lbs.
96"	750 lbs.	1250 lbs.

**LIMITED WARRANTY**

Tennsco warrants goods purchased hereunder to be free of defects in materials and workmanship for a period of one (1) year from the date of shipment, hereunder. This warranty shall not apply in the event goods are damaged as a result of misuse, abuse, neglect, accident, improper application, modification or repair by persons not authorized by Seller, where goods are damaged during shipment, or where the date stamps on the goods have been defaced, modified or removed. UNLESS CONSIDERED UNENFORCEABLE OR UNLAWFUL UNDER APPLICABLE LAW:

- a. ALL IMPLIED WARRANTIES, INCLUDING BUT NOT LIMITED TO WARRANTIES OR MERCHANTABILITY AND FITNESS FOR A PARTICULAR PURPOSE ARE HEREBY EXCLUDED:
- b. BUYERS REMEDY, IF ANY, FOR ANY DEFECTIVE GOODS SHALL BE LIMITED TO A REFUND BY SELLER OR REPLACEMENT OF THE GOODS AT SELLER'S OPTION, AND SHALL IN NO EVENT INCLUDE DAMAGES OF ANY KIND, WHETHER INCIDENTAL, CONSEQUENTIAL OR OTHERWISE.

NO GOODS ACCEPTED FOR RETURN WITHOUT PRIOR APPROVAL. Seller shall have the right to inspect any goods claimed to be defective at Buyers place of business or require Buyer to return the goods to Seller for inspection on Seller's premises. Transportation charges covering returned goods will be borne by Seller only if such goods are proven to be defective, are covered by this warranty and are returned within the warranty period stated above.

TENNSCO CORP., P.O. BOX 1888, DICKSON, TN 37056-1888  
(615) 446-8000 (800) 251-8184

# ASSEMBLY OF STANDARD BOLTLESS RACK

Tools Needed: A rubber mallet for seating the shelf supports. Two people are recommended for assembly.

Approximate assembly time: 15 to 30 minutes per section.

1. The reference numbers used throughout this sheet refer to the illustration on the back cover. This is to help you to identify the various parts as they are mentioned.

2. Depending upon whether you ordered a single unit or an adder unit, you may have one or both of the styles of upright shown at right:

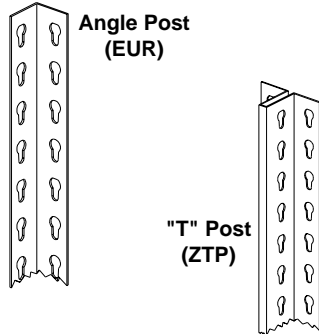

A single unit will use EUR posts for all four uprights, as shown below in Figure A. If you plan on installing an adder unit, however, you should build your starter unit with two ZTP posts on one end (which will join with the adder), as shown in Figure B.

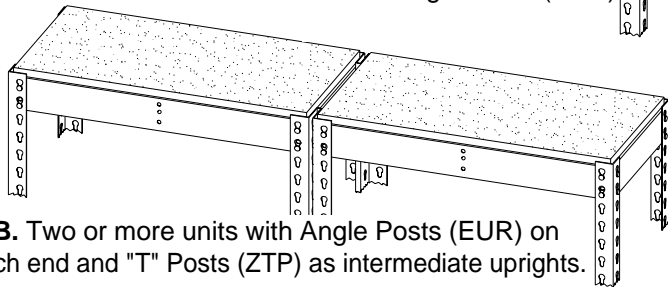
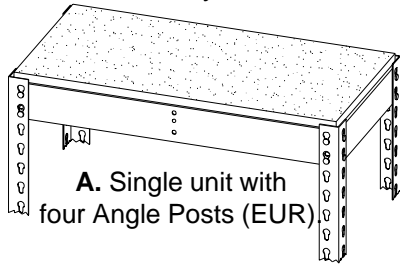

3. With help from an associate, or using a wall for support, connect two EUR uprights (Ref. No. 1a) together with two front-to-back supports (Ref. No. 2), one at the top and one at the bottom. Be sure the front-to-back supports are fully seated in the keyhole slots, as shown at right.

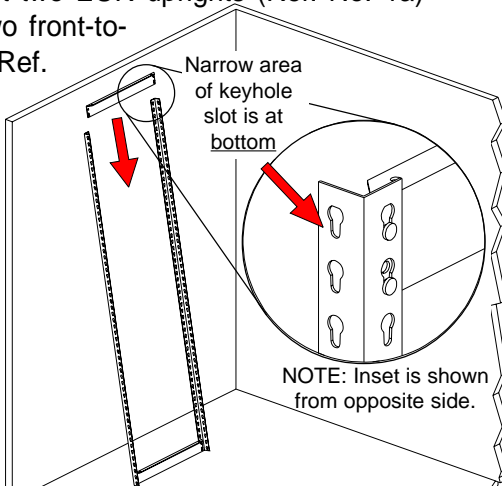

**IMPORTANT!** All shelf supports must be installed with the flange facing UP, as shown at right. This flange is what the shelves will rest on.

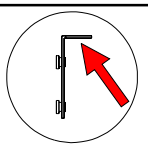

4. Place a third front-to-back end support in the middle slots of the two uprights (or at whatever level you want your third shelf to be). This forms one end of the shelving unit.

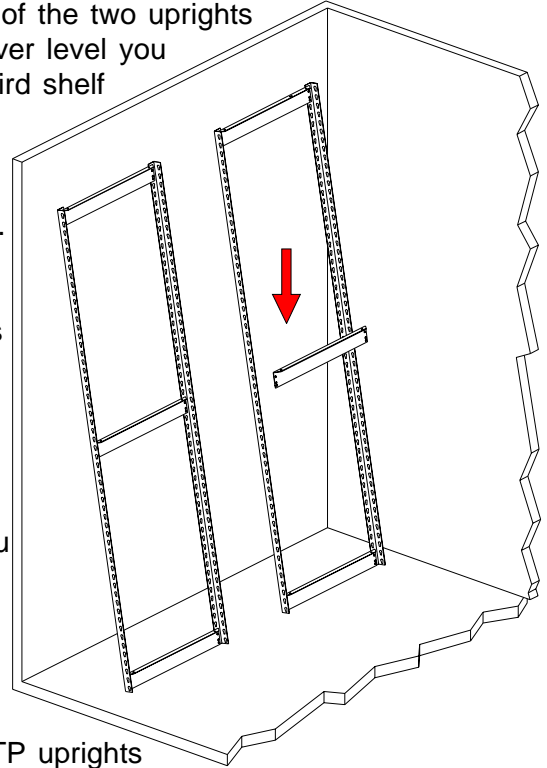

5. Repeat steps 3 and 4 to construct a second set of unit ends.

**NOTE:** If you are planning to install an adder unit, this second set should consist of ZTP uprights (Ref. No. 1b) so that adjacent sections can be tied together. Carefully review step 2 and step 10 to better understand this.

6. With the help of an associate, connect the two unit ends with left-to-right shelf supports (Ref. No. 3). Again, be sure that the flange on the shelf support is facing up, and that the shelf supports are fully seated, as was illustrated in step 3.

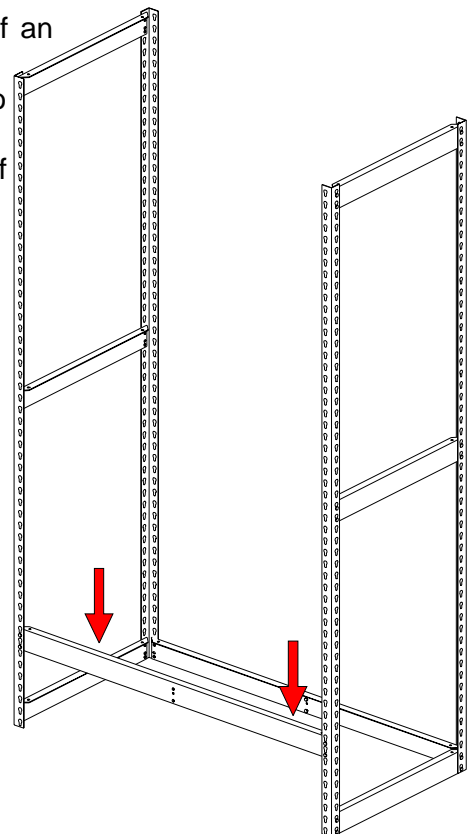

7. Attach the remaining shelf supports at the desired shelf levels, making sure that all shelf supports are completely seated in the upright slots.

**NOTE:** If you have purchased additional shelf levels, the shelf supports for the extra levels may also be inserted at this time.

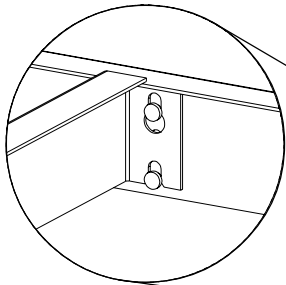
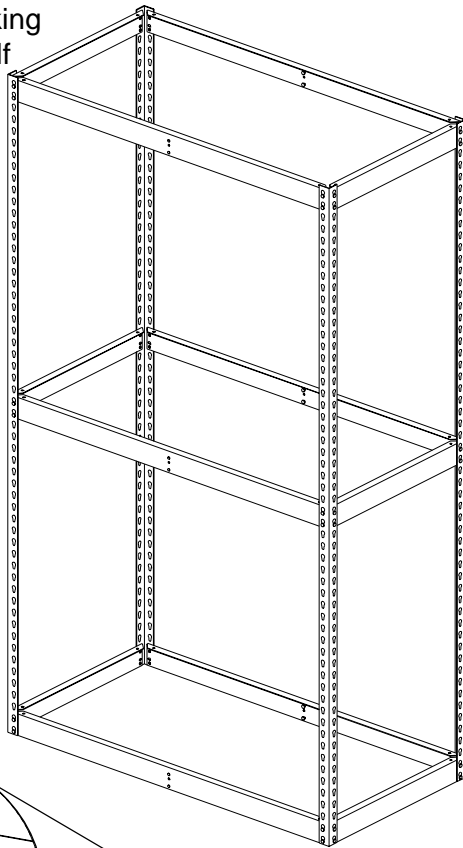

8. Attach shelf reinforcements (Ref. No. 4) at each level by inserting the keyhole slots on the reinforcement over the rivets on the supports and tapping them firmly into place, as shown above.

**NOTE:** Recommended number of reinforcements per shelf are as follows:

- 48" w = 1 reinforcement
- 72" w = 2 reinforcements
- 96" w = 3 reinforcements

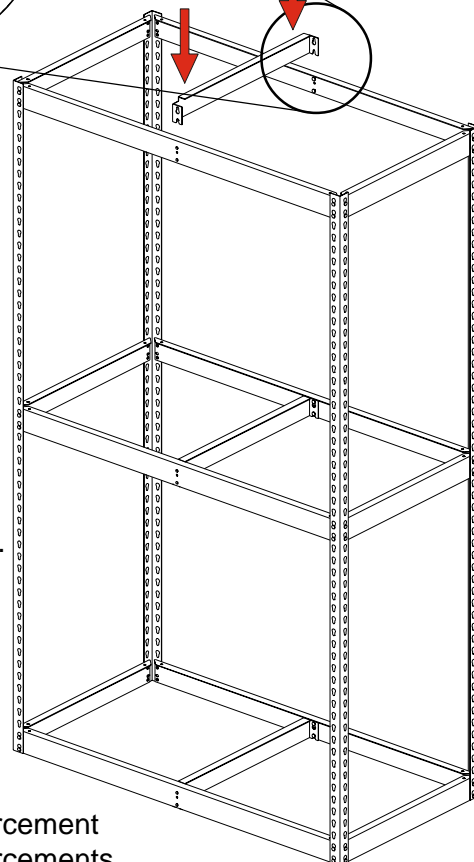

9. If particleboard decking (Ref. No. 5) was ordered, place the decking on each shelving level. The decking should fit flat on top of the shelf supports and reinforcements.

**NOTE:** If you ordered wire decking, it will fit onto the unit in the same way as described above.

If you have purchased a single unit, your shelving unit is now complete and ready to use. For adder units, see step 10.

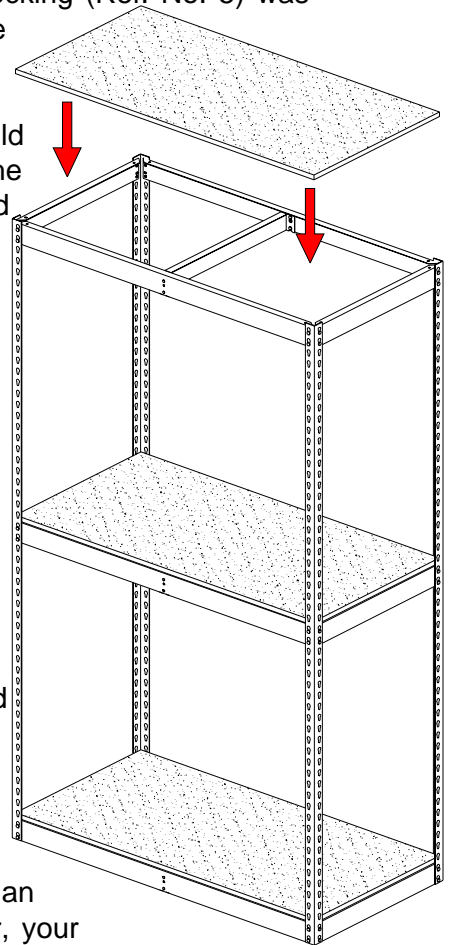

10. If joining more than one unit together, your original unit should have been assembled with ZTP uprights on one end, as described in step 5. Simply continue adding shelf supports and uprights to complete your additional units.

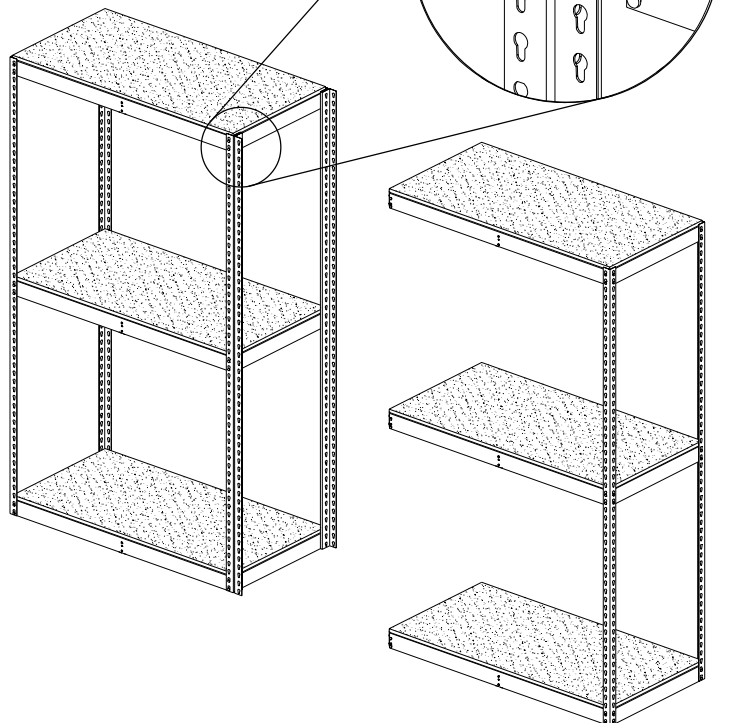

# REPLACEMENT PARTS

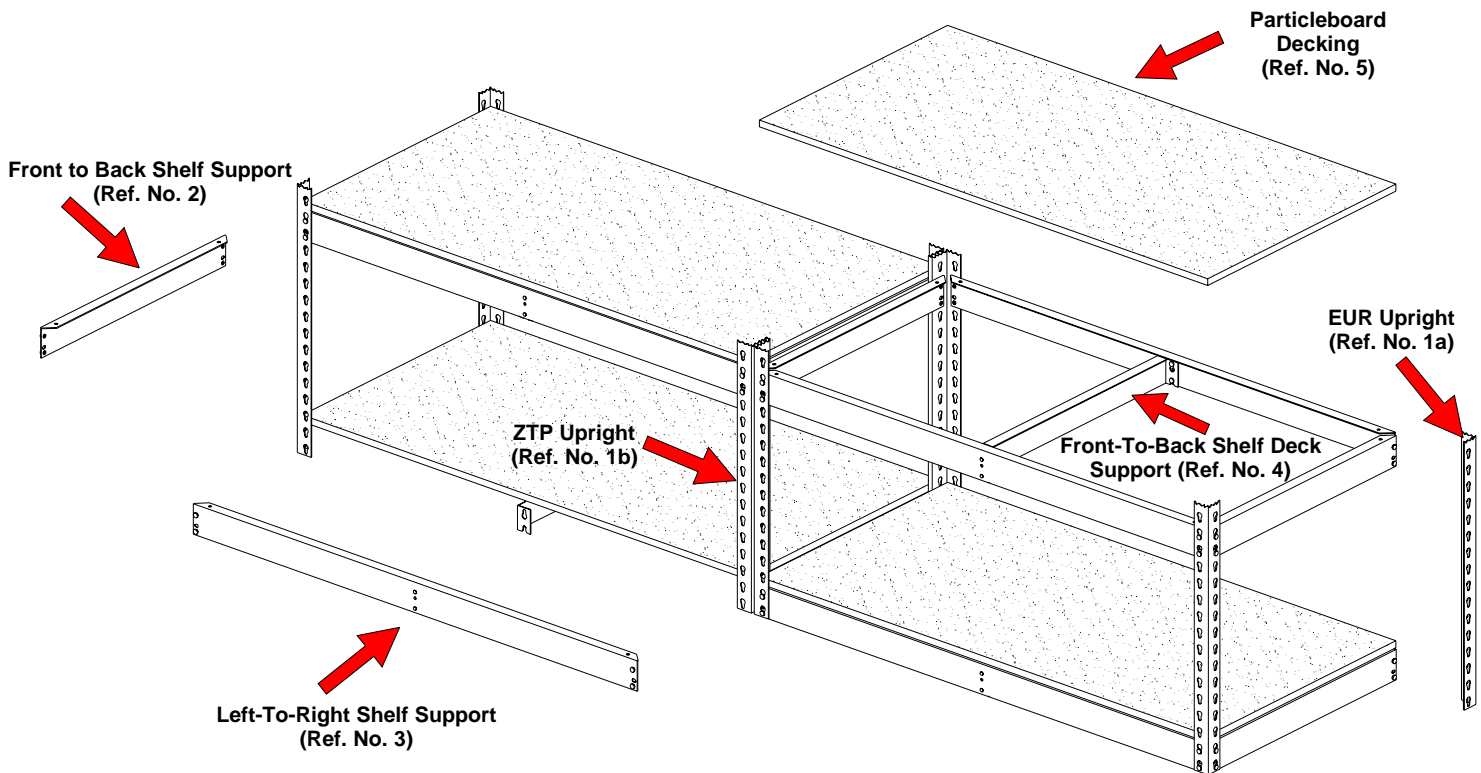

SINGLE OR STARTER UNIT				ADDER UNIT			
REF. NO.	DESCRIPTION	QTY.*	PART NO.**	REF. NO.	DESCRIPTION	QTY.*	PART NO.**
1a	Angle Post	4	EUR-hh	1b	"T" Post	2	ZTP-hh
2	Front-to-Back Shelf Support	6	LRA-dd	2	Front-To-Back Shelf Support	6	LRA-dd
3	Left-To-Right Shelf Support	6	LRA-ww	3	Left-To-Right Shelf Support	6	LRA-ww
4	Front-To-Back Shelf Deck Support	1-3	SDS-dd	4	Front-To-Back Shelf Deck Support	1-3	SDS-dd
5	Optional Particleboard Decking	3	PB-wydd	5	Optional Particleboard Decking	3	PB-wydd

\*Quantities apply to the basic 3-shelf unit only. If you have ordered additional shelf levels, quantities will vary accordingly.

On items where a range is given, quantities will vary depending upon number of deck supports you received.

\*\*Where the suffix "ww", "dd", or "hh" is used in the part number, the width (ww), depth (dd) or height (hh) is substituted in the part number. For example, for an 84" high Angle Post, the part number would be EUR-84.

**Tennsco makes every effort to ensure that all units ship complete with all parts and arrive undamaged. However, should your unit contain missing or damaged parts, replacements may be obtained directly from Tennsco. To obtain proper replacement parts, follow the instructions below:**

### TO OBTAIN PROPER REPLACEMENT PARTS, PLEASE PROVIDE THE FOLLOWING INFORMATION:

- Description of part(s) needed and part number(s) as shown in Parts List (above)
- Color (i.e. Medium Grey, etc.)
- Was item missing, or was it damaged?
- Purchase Date
- Your company name
- Contact person's name
- Who the product was purchased from

**Tennsco Corp., P.O. Box 1888, Dickson, TN 37056-1888    Voice: (800) 251-8184    Fax: (800) 722-0134**  
 If requesting parts by telephone, ask for customer service and have as much of the above information ready as possible.