

# The Ultimate DollyCart™

## Packing List:

- |   |                                 |
|---|---------------------------------|
| (1) DollyCart™ Frame w/ (2) U-Bolts, (4) Washers, (4) Lock-Washers, (4) M-6 Lock-Nuts | (1) Tailgate                    |
| (1) Solid Steel Axle w/ (4) Sealed Ballbearings, (2) Axle Washers, (2) M-14 Lock-Nuts | (1) Handle Arm w/ Towel Bar     |
| (2) Spare Axle Washers, (2) QuickClips™, (4) Lock-Washers,                            | (2) Heavy-Duty Wheel Assemblies |
| (4) Wing-Nuts (packaged on DollyCart™ frame)  | (2) DollyCart™ Legs             |

Tools Required for Assembly: 10mm Wrench (socket wrench recommended), Crescent Wrench

## ASSEMBLY INSTRUCTIONS

### ① Axle Installation

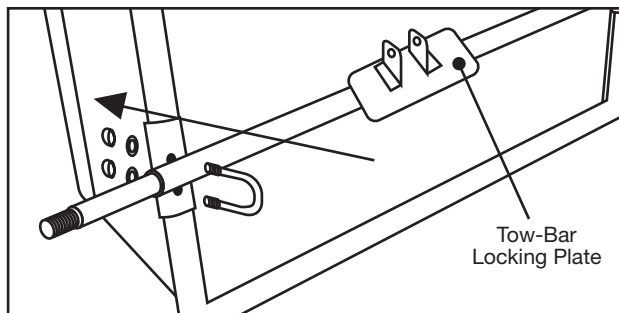

1. Lightly secure axle to DollyCart™ frame using the u-bolts, washers and lock-nuts supplied.
2. Center the axle on the DollyCart™ frame and secure the tow-bar locking plate at a 90° angle to the cart with the pin brackets on top.
3. Carefully tighten lock-nuts to secure axle.

### ② Wheel Installation

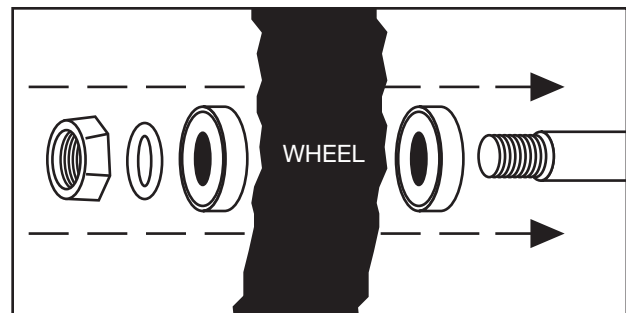

1. Slide components onto axle in the following order: (1) bearing, (2) wheel, (3) bearing, (4) axle washer.
2. Screw large (M-14) lock-nut onto axle shaft. **DO NOT OVER-TIGHTEN.** Tighten until components are snug, but wheel spins freely.
3. Check for firm tire pressure (28psi max).

### ③ Installation of Legs

The legs keep the DollyCart™ level in the cart configuration and are used as handles for dumping in the dolly configuration. The legs can be left on when converting between dolly and cart.

1. Remove plastic shipping plugs from leg support locking base sockets.
2. Press in the leg locking pins and pull legs out of horizontal socket locking bases. Push the legs into the leg support locking base while pressing in the locking pins. Make sure both locking pins are extended through the leg support locking base holes.

### ④ Tailgate Mounting

#### In the Dolly Configuration

Slide tailgate into guides on handle arms to add height to the dolly and provide a place to hold Garden Caddy and Saddle Rack accessories.

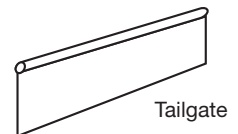

#### In the Cart Configuration

Slide tailgate into guides on back of cart frame. Install tailgate before attaching handles. The handles lock the tailgate in place.

### ⑤ Handle Installation

The handle is installed in the dolly configuration (Fig. A) or cart configuration (Fig. B).

**Dolly Configuration:** Use 2 QuickClips (Fig. C) to secure handle arms to back of the DollyCart™ frame with the handle angled back as shown in Fig. A.

**Cart Configuration:** Mount tailgate before installing handles. Use 2 QuickClips (Fig. C) to secure handle arms to front of the DollyCart™ frame with the handle angled up as shown in Fig. B.

**QuickClips:** The QuickClip spring-action allows for rapid conversion between dolly and cart. QuickClips slip through the frame then handle so that wing-nuts are on the outside of the DollyCart™.

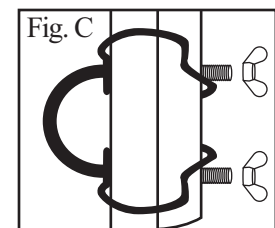
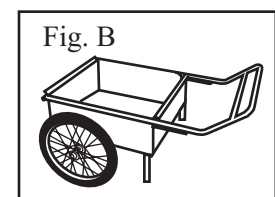
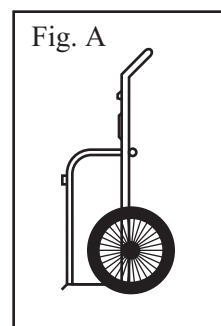

Right-hand assembly shown.

For more information, visit our website at [www.dollycart.com](http://www.dollycart.com)