

**MAGNETIC RECUMBENT BIKE**  
**MAGNETIC ROWER**

**CONVERSION™**



**9002**

## Owner's Manual

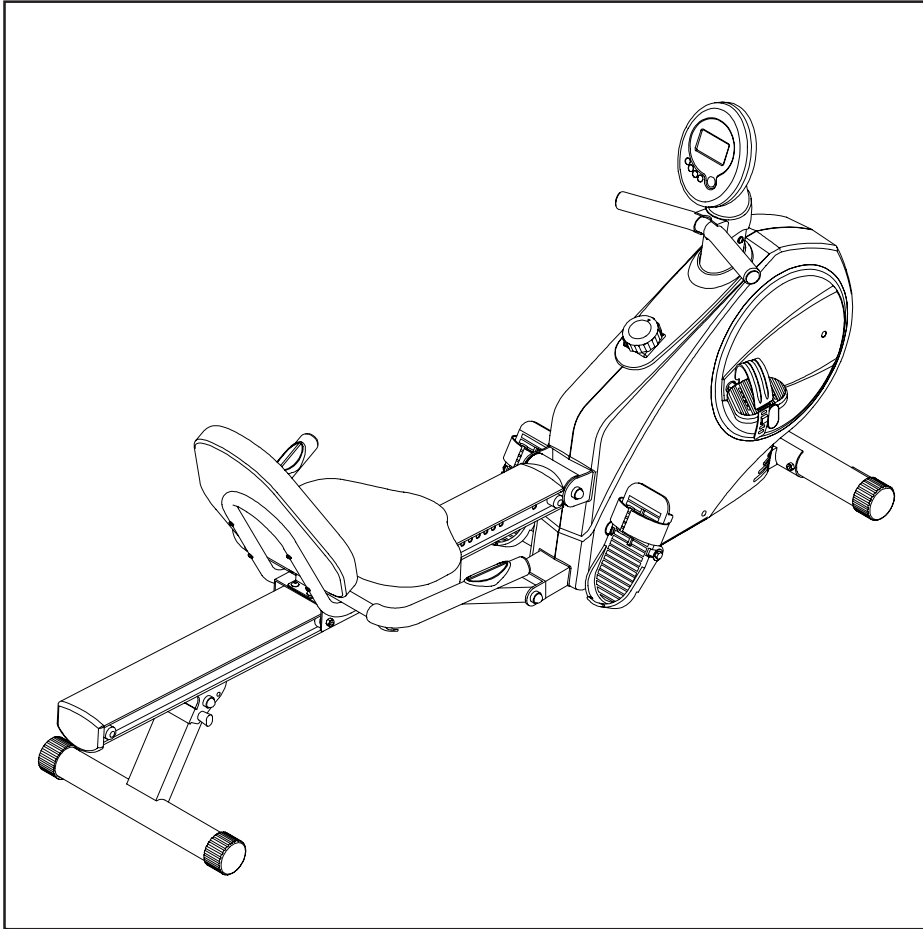

**CAUTION:**

Weight on this product should not exceed 250 lbs.

**! WARNING !**

Exercise can present a health risk. Consult a physician before beginning any exercise program with this equipment. If you feel faint or dizzy, immediately discontinue use of this equipment. Serious bodily injury can occur if this equipment is not assembled and used correctly. Serious bodily injury can also occur if all instructions are not followed. Keep others and pets away from equipment when in use. Always make sure all bolts and nuts are tightened prior to each use. Follow all safety instructions in this manual.

When calling for parts or service, please specify the following number.

**15-9002**  
**STAMINA PRODUCTS**  
MADE IN TAIWAN

Product May Vary Slightly  
From Pictured.

This Product is Produced Exclusively by



2040 N. Alliance, Springfield, MO 65803

Customer Service Number

1 (800) 375-7520

[www.staminaproducts.com](http://www.staminaproducts.com)

## TABLE OF CONTENTS

	Page		Page
Safety Instructions	2	Conditioning Guidelines	15
Before You Begin	4	Warm-up and Cool-Down	16
Hardware Illustrations	5	Warranty	17
Assembly Instructions	6	Product Parts Drawing	18
Using The Electronic Meter	11	Parts List	19
Operational Instructions	12	Notes	21
Maintenance	13	Fax/Mail Ordering Form	22
Storage	14		

### SAFETY INSTRUCTIONS

**WARNING:** To reduce the risk of serious injury, read the following Safety Instructions before using the **Conversion II™ 9002**.

1. Read all warnings posted on the **Conversion II™ 9002**.
2. Read this Owner's Manual and follow it carefully before using the **Conversion II™ 9002**. Make sure that it is properly assembled and tightened before use.
3. Keep children away from the **Conversion II™ 9002**. Do not allow children to use or play on the **Conversion II™ 9002**. Keep children and pets away from the **Conversion II™ 9002** when it is in use.
4. Set up and operate the **Conversion II™ 9002** on a solid level surface. Do not position the **Conversion II™ 9002** on loose rugs or uneven surfaces.
5. Inspect the **Conversion II™ 9002** for worn or loose components prior to use.
6. Tighten/replace any loose or worn components prior to using the **Conversion II™ 9002**.
7. Make sure the Rear Support(62) is locked properly with the Pull Pin(63) before using the **Conversion II™ 9002**.
8. Make sure the Rail(52) is locked properly by the Release Knob(59) located on the Support Tube(56) when in storage.
9. Keep fingers clear of all pinch points when folding and unfolding the **Conversion II™ 9002**.
10. Lock seat in position with at least one adjustment hole visible in front of the seat before lifting rail to storage position. This will prevent the seat from damaging the covers.
11. Consult a physician prior to commencing an exercise program. If, at any time during exercise, you feel faint, dizzy, or experience pain, stop and consult your physician.
12. Follow your physician's recommendations in developing your own personal fitness program.
13. Always choose the workout which best fits your physical strength and flexibility level. Know your limits and train within them. Always use common sense when exercising.
14. Do not wear loose or dangling clothing while using the **Conversion II™ 9002**.
15. Never exercise in bare feet or socks; always wear correct footwear, such as running, walking, or crosstraining shoes. Be sure that they fit well, provide foot support and feature non-skid rubber soles.
16. Be careful to maintain your balance while using, mounting, dismounting, or assembling the **Conversion II™ 9002**, loss of balance may result in a fall and serious bodily injury.
17. The **Conversion II™ 9002** should not be used by persons weighing over 250 pounds.
18. The **Conversion II™ 9002** should be used by only one person at a time.
19. The **Conversion II™ 9002** is for consumer use only. It is not for use in public or semipublic facilities.

**WARNING:** Before starting any exercise or conditioning program you should consult with your personal physician to see if you require a complete physical exam. This is especially important if you are over the age of 35, have never exercised before, are pregnant, or suffer from any illness. **READ AND FOLLOW THE SAFETY PRECAUTIONS. FAILURE TO FOLLOW THESE INSTRUCTIONS CAN RESULT IN SERIOUS BODILY INJURY.**

# CALL US FIRST



**CUSTOMER SERVICE NUMBER**  
**1 (800) 375-7520**

---

**THANK YOU FOR PURCHASING THE**  
**Conversion II™ 9002**

To help you get started, we have pre-assembled most of your Conversion II™ 9002 at the factory with the exception of those few parts left unassembled for shipping purposes. Simply follow the few assembly instructions set forth in this manual. Within a few minutes you will be getting your body into shape and on your way to achieving a happier and healthier lifestyle.

Should you have any questions,  
please call our Customer Service Department toll-free number,  
**1 (800) 375-7520**  
Monday - Friday, 8:00 A.M. - 5:00 P.M., Central Time.

## BEFORE YOU BEGIN

Thank you for choosing the **Conversion II™ 9002**. We take great pride in producing this quality product and hope it will provide many hours of quality exercise to make you feel better, look better and enjoy life to its fullest.

Yes, it's a proven fact that a regular exercise program can improve your physical and mental health. Too often, our busy lifestyles limit our time and opportunity to exercise. The **Conversion II™ 9002** provides a convenient and simple method to begin your assault on getting your body in shape and achieving a happier and healthier lifestyle.

Before reading further, please review the drawing below and familiarize yourself with the parts that are labeled.

Read this manual carefully before using the **Conversion II™ 9002**.

Although Stamina tries to manufacture its products with the finest materials and uses the highest standards of manufacturing, occasionally a part that does not fit, is the incorrect size, or is otherwise inappropriate is found. Even with the highest inspection and quality controls in place these things will happen occasionally. Please do not return the product. For your convenience, Stamina has a Customer Service Department with a toll-free number. If a part is missing, does not fit, is the incorrect size, or is otherwise inappropriate, please call 1 (800) 375-7520 (in the U.S.) between 8:00 A.M. and 5:00 P.M. Central Time, Monday through Friday. Our operators will be able to assist you with your problem and the parts will be mailed directly to your house.

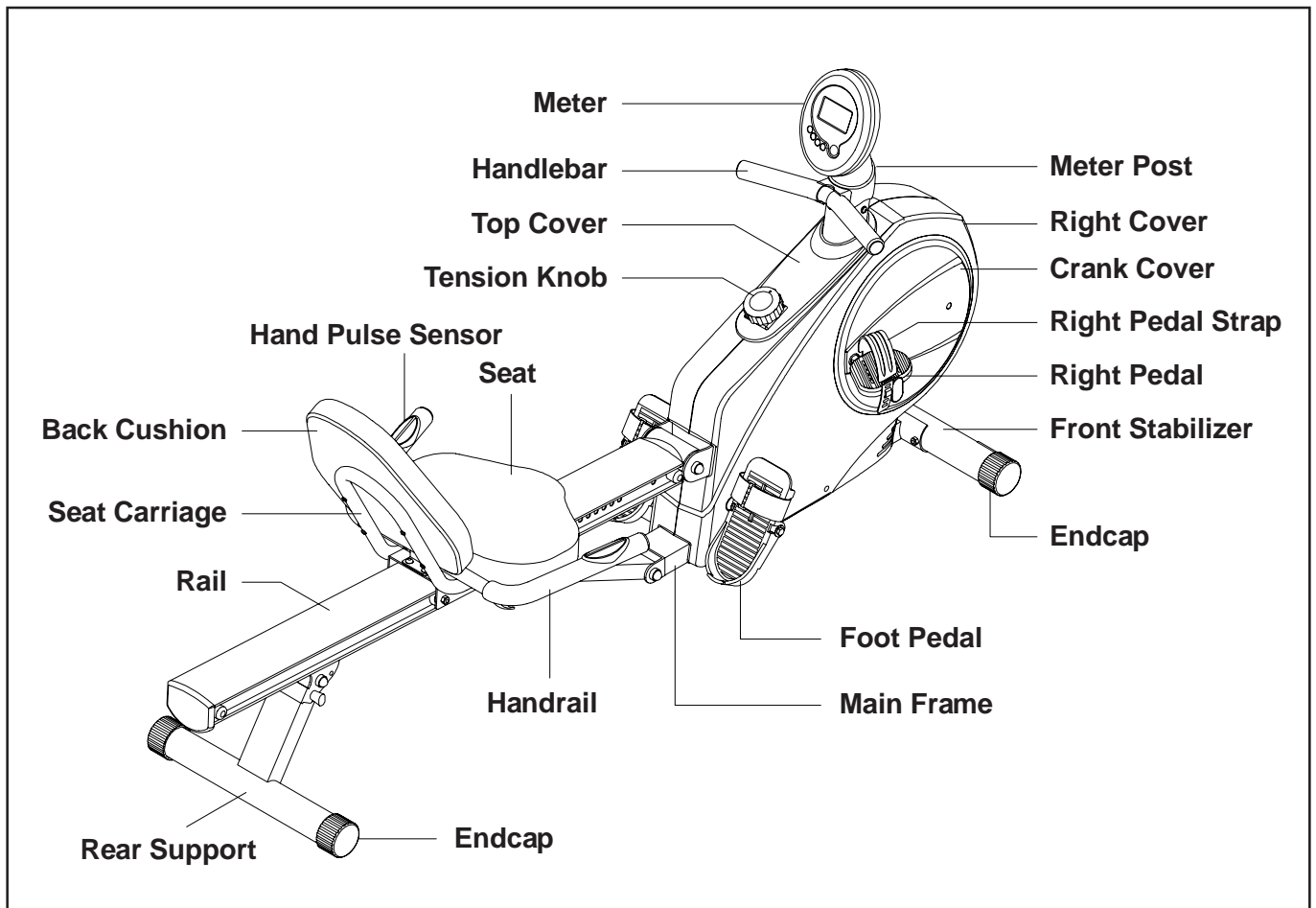

### THE FOLLOWING TOOLS ARE REQUIRED FOR ASSEMBLY :

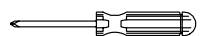

Phillips Screwdriver



Adjustable Wrench

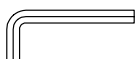

Allen Wrench (6mm)(2 Wrenches Included)









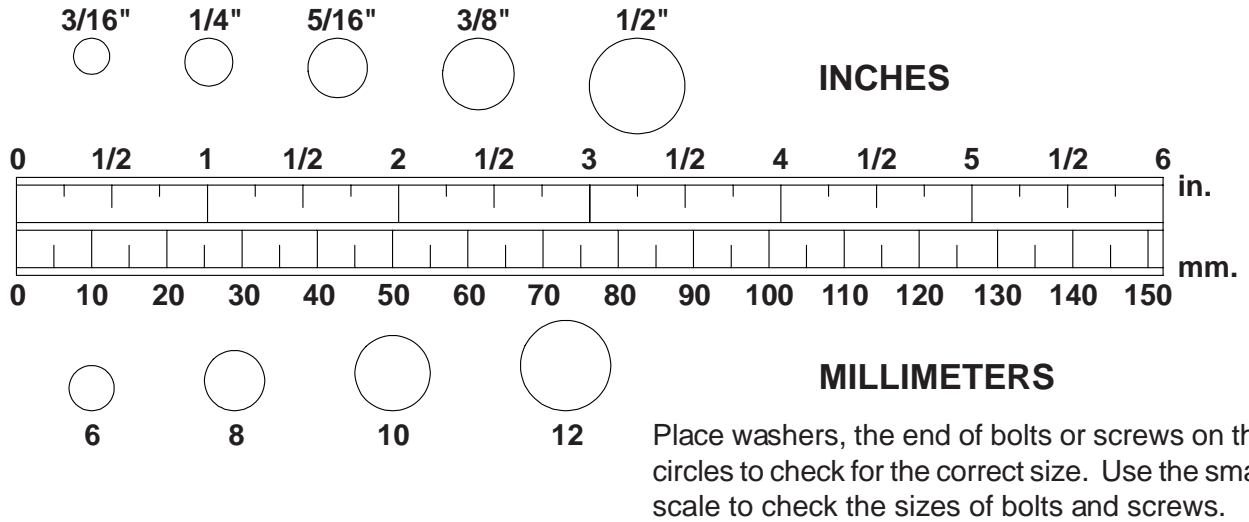

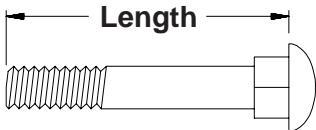

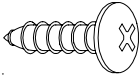
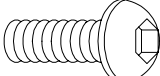

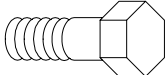
Adjustable Wrench

# HARDWARE IDENTIFICATION CHART

This chart is provided to help identify the hardware used in the assembly process. After unpacking the unit, open the hardware bag and make sure that you have the following items:

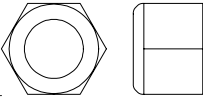

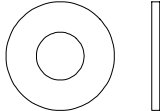
	Part No. and Description	Qty
	81 Carriage Bolt (M8 x 1.25 x 70mm)	2
	84 Screw, Round Head (M5 x 18mm)	1
	94 Bolt, Button Head (M8 x 1.25 x 15mm)	3
	114 Bolt, Button Head (M8 x 1.25 x 12mm)	4
	95 Bolt, Hex Head (M6 x 1 x 15mm)	4
	96 Bolt, Hex Head (M6 x 1 x 30mm)	4
	97 Bolt, Hex Head (M8 x 1.25 x 16mm)	4
	101 Bolt, Hex Head (M10 x 1.5 x 85mm)	1
	102 Bolt, Hex Head (M10 x 1.5 x 95mm)	1
	103 Bolt, Hex Head (M10 x 1.5 x 125mm)	1
	104 Nylock Nut (M8 x 1.25)	2
	105 Nylock Nut (M10 x 1.5)	3
	109 Large Washer (M8 x $\varnothing$ 23)	2

**NOTE:** Some of the hardware items listed may be attached to other parts.

## ASSEMBLY INSTRUCTIONS

Place all parts from the box in a cleared area and position them on the floor in front of you. Remove all packing materials from your area and place them back into the box. Do not dispose of the packing materials until assembly is completed. Read each step carefully before beginning. If you are missing a part please call our toll-free number for assistance **1 (800) 375-7520** or e-mail us at: **parts@staminaproducts.com**

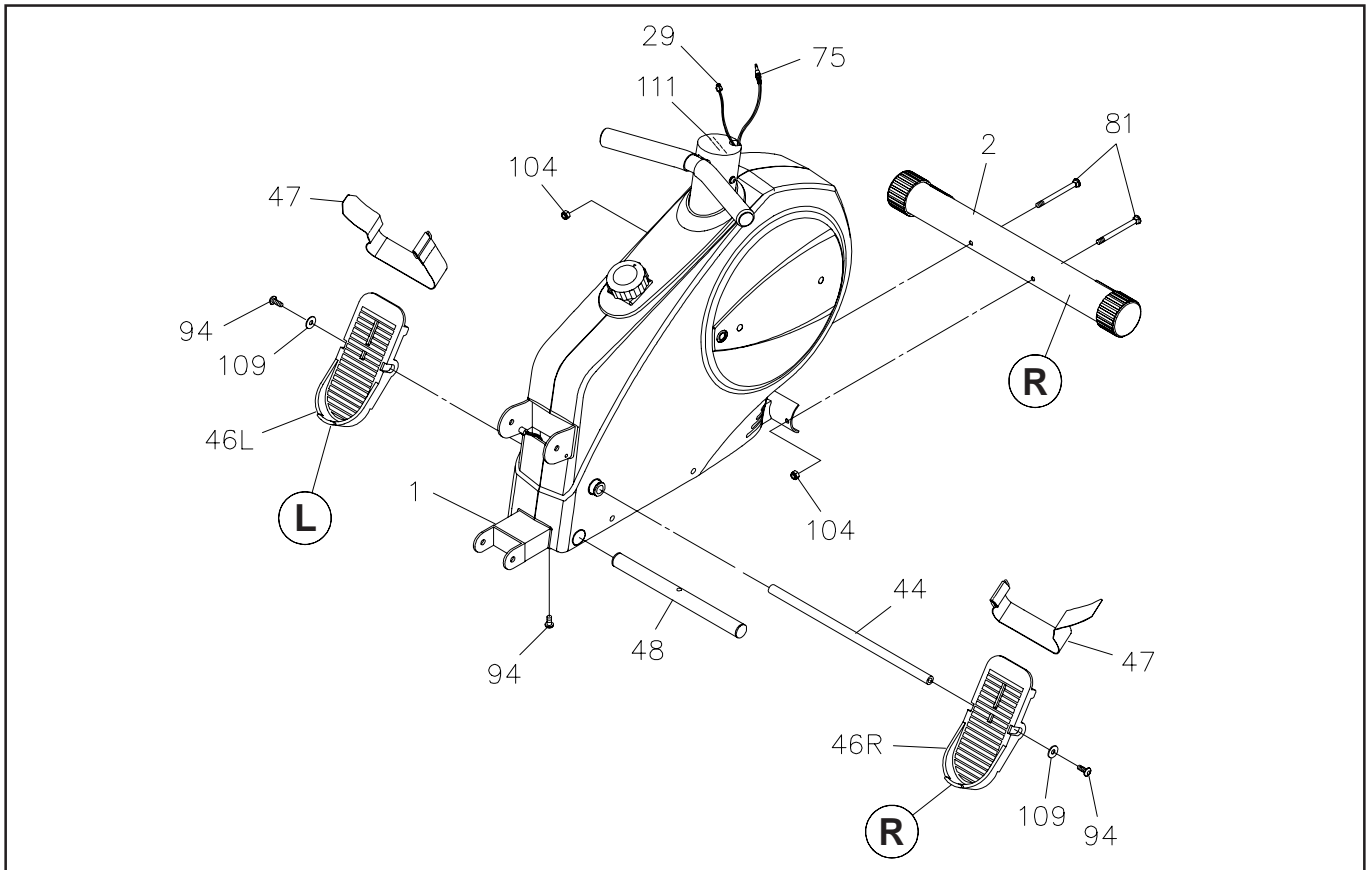

**NOTE:** Don't remove or damage the **DECAL(111)** located on the top of the **MAIN FRAME(1)**. The **DECAL(111)** is for securing the Sensor Wires drop into the Upright Tube.

**STEP 1:** There is a "R" decal on one end of the **FRONT STABILIZER(2)**. Attach the **FRONT STABILIZER(2)** onto the **MAIN FRAME(1)** with the "R" decal end at right side and secure with **CARRIAGE BOLTS(M8 x 70mm)(81)** and **NYLOCK NUTS(M8)(104)**.

**STEP 2:** Insert the **STOPPER TUBE(48)** through the **MAIN FRAME(1)** and secure with **BUTTON HEAD BOLT(M8 x 15mm)(94)**.

**NOTE:** The **PEDAL STRAPS(47)** are pre-assembled to the **FOOT PEDALS(46)**. The pedal and strap assembly for the left side has a "L" decal. The pedal and strap assembly for the right side has a "R" decal.

**STEP 3:** Insert the **PEDAL SHAFT(44)** through the **MAIN FRAME(1)**. Place the **RIGHT FOOT PEDAL ASSEMBLY(46R)** onto the right end of the **PEDAL SHAFT(44)** and place the **LEFT FOOT PEDAL ASSEMBLY(46L)** onto the left end. Secure the **FOOT PEDALS** with **BUTTON HEAD BOLTS (M8 x 15mm)(94)** and **LARGE WASHERS(M8)(109)** at both ends of the **PEDAL SHAFT(44)**.

**NOTE:** You need to use two Allen Wrenches to tighten the **BUTTON HEAD BOLTS(M8 x 15mm)(94)** at both ends of the **PEDAL SHAFT(44)** at the same time.

## ASSEMBLY INSTRUCTIONS

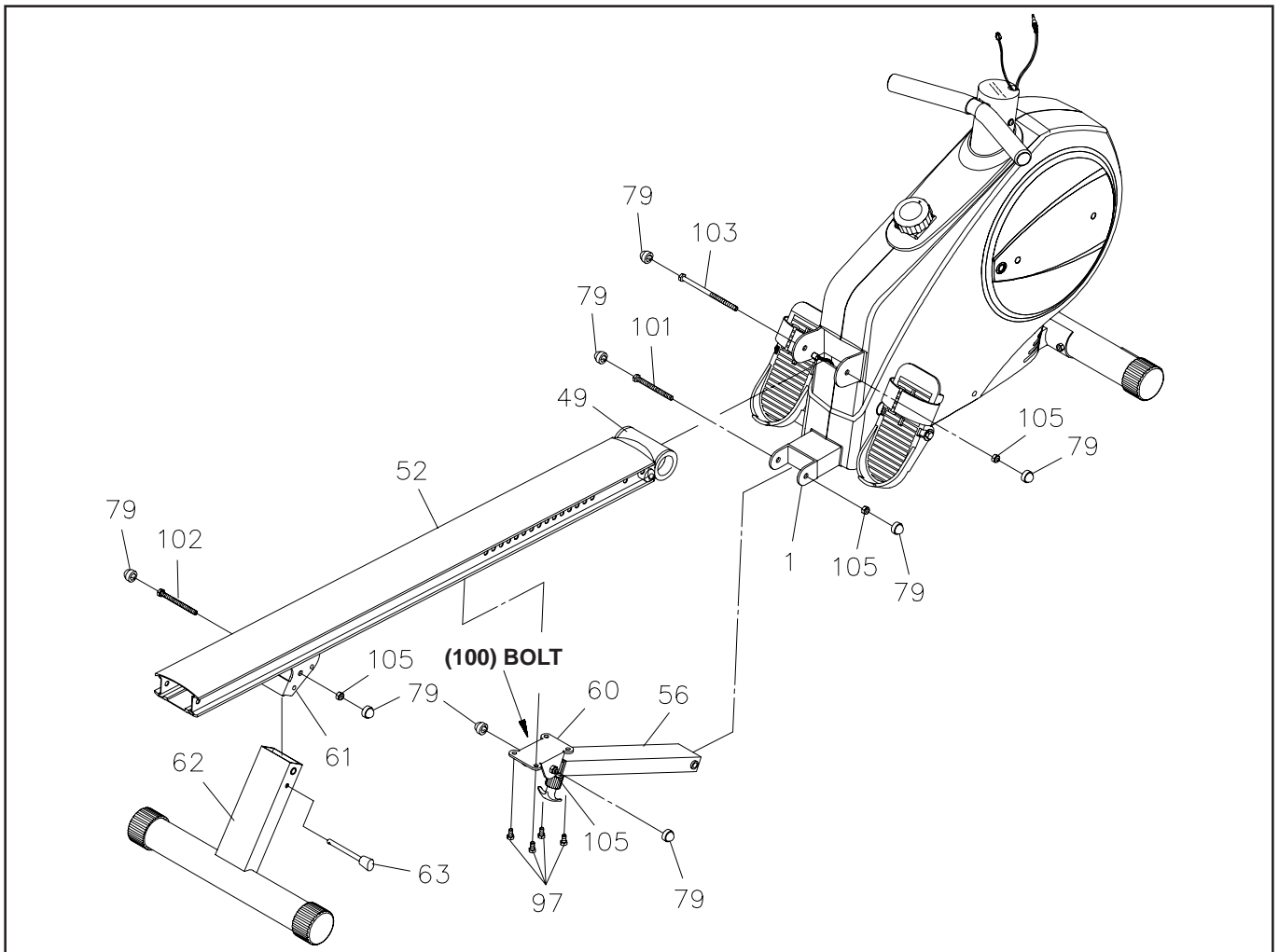

### STEP 4

Attach the **SUPPORT BRACKET(60)** onto the **RAIL(52)** with **HEX BOLTS(M8 x 16mm)(97)**. Press the **NUT CAPS(79)** onto **NYLOCK NUT(M10)(105)** and **HEX BOLT(M10 x 75mm)(100)**.

### STEP 5

Attach the **RAIL(52)** onto the **MAIN FRAME(1)** by sliding the **RAIL PIVOT(49)** into the bracket on the **MAIN FRAME(1)** and securing with **HEX BOLT(M10 x 125mm)(103)** and **NYLOCK NUT(M10)(105)**. Press the **NUT CAPS(79)** onto **HEX BOLT(M10 x 125mm)(103)** and **NYLOCK NUT(M10)(105)**.

### STEP 6

Connect the lower end of the **SUPPORT TUBE(56)** to the **MAIN FRAME(1)** with **HEX BOLT (M10 x 85mm)(101)** and **NYLOCK NUT(M10)(105)**. Press the **NUT CAPS(79)** onto **HEX BOLT (M10 x 85mm)(101)** and **NYLOCK NUT(M10)(105)**.

### STEP 7

Attach the **REAR SUPPORT(62)** into the **REAR SUPPORT BRACKET(61)** located on the **RAIL(52)** with **HEX BOLT(M10 x 95mm)(102)** and **NYLOCK NUT(M10)(105)**. Lock the **REAR SUPPORT(62)** in position with the **PULL PIN(63)**. Press the **NUT CAPS(79)** onto **HEX BOLT(M10 x 95mm)(102)** and **NYLOCK NUT(M10)(105)**.

## ASSEMBLY INSTRUCTIONS

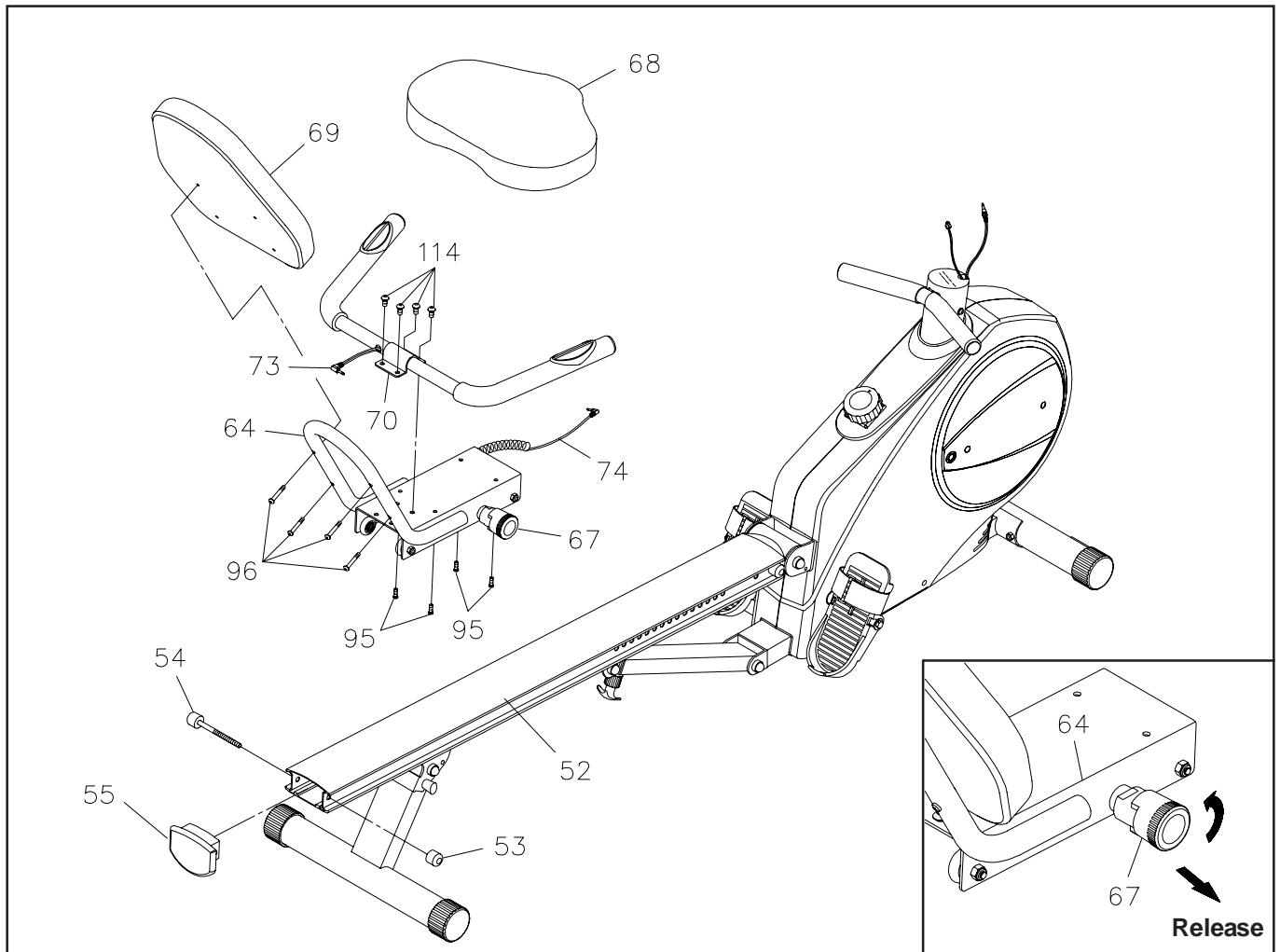

**NOTE:** Be careful not to damage the **PULSE SENSOR WIRES(73, 74)** while doing assembly Step 8 to Step 10.

### STEP 8

Attach the **HANDRAIL(70)** onto the **SEAT CARRIAGE(64)** with **BUTTON HEAD BOLTS(M8 x 12mm)(114)**.

### STEP 9

Attach the **SEAT(68)** onto the **SEAT CARRIAGE(64)** with **HEX BOLTS(M6 x 15mm)(95)**. Attach the **BACK CUSHION(69)** onto the **SEAT CARRIAGE(64)** with **HEX BOLTS(M6 x 30mm)(96)**.

### STEP 10

Turn the knob of the **SPRING PIN(67)** counterclockwise and lock the knob in the release position, refer to the inset drawing. Slide the **SEAT CARRIAGE ASSEMBLY(64)** onto the **RAIL(52)**.

Press the **RAIL CAP(55)** into the back end of the **RAIL(52)**. Insert the **STOPPER BOLT(54)** through the **RAIL(52)** and **RAIL CAP(55)** to bolt them together with the **STOPPER(53)**. Please verify that the other **STOPPER BOLT(54)** at the front end of **RAIL(52)** was assembled at the factory.

## ASSEMBLY INSTRUCTIONS

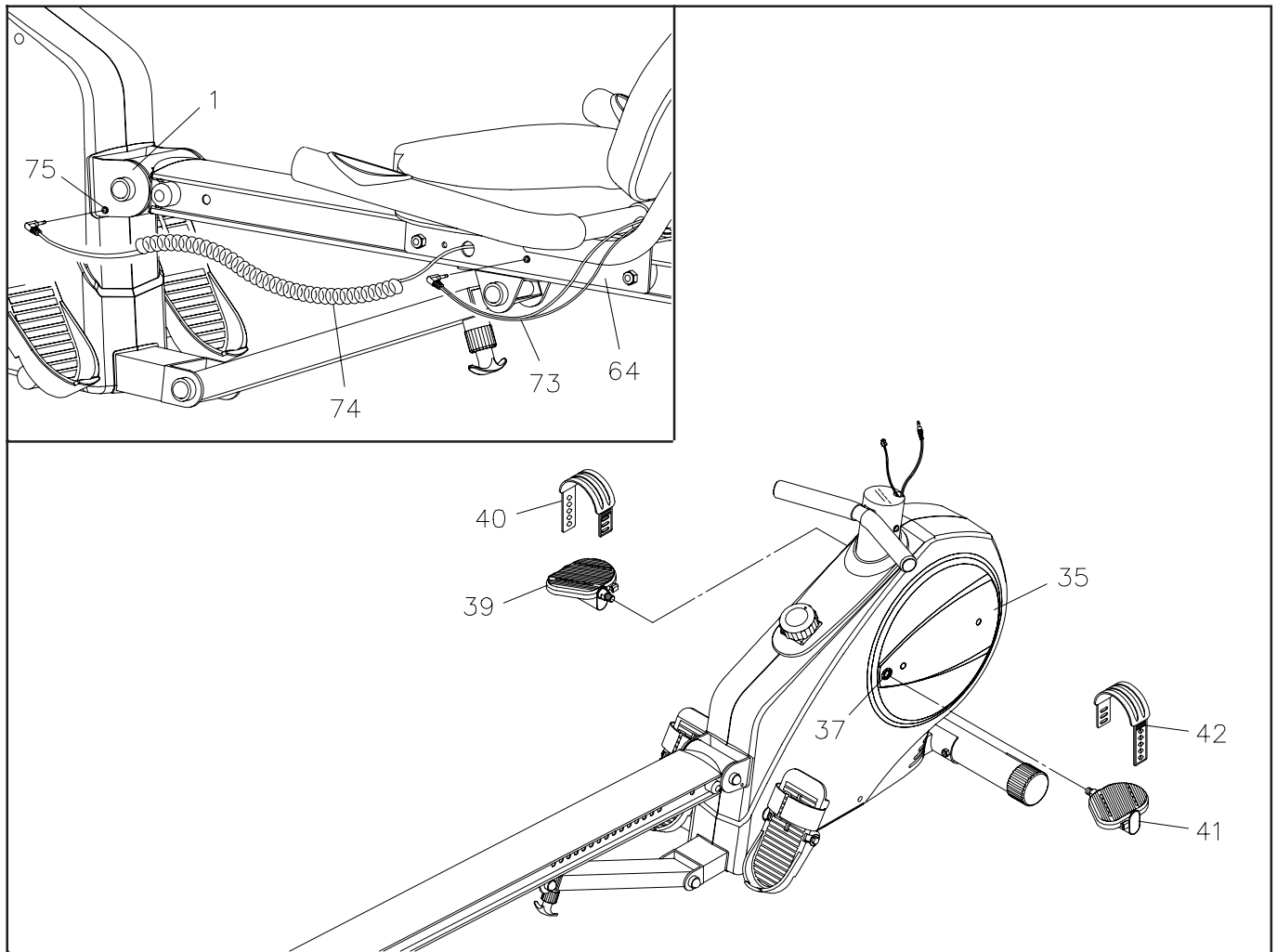

### STEP 11

**NOTE:** The **RIGHT PEDAL(41)** has **R** stamped on the end of the pedal shaft. The **RIGHT PEDAL(41)** has right hand threads and is tightened by turning clockwise. The **LEFT PEDAL(39)** has **L** stamped on the end of the pedal shaft. The **LEFT PEDAL(39)** has left hand threads and is tightened by turning counter clockwise.

Thread the **RIGHT PEDAL(41)** onto the **RIGHT CRANK(37)** located at inside of the **CRANK COVER(35)** as shown. Tighten the pedal securely. Select the **RIGHT PEDAL STRAP(42)** which has **R** marked on the bottom side of the strap. Snap the three hole end onto the inside edge of the **RIGHT PEDAL(41)**. Snap the other end onto the outside edge of the **RIGHT PEDAL(41)** with the **R** mark on the bottom of the **RIGHT PEDAL STRAP(42)**. Select adjustment holes which allow your foot to be easily removed from the pedals.

Do the same way to attach the **LEFT PEDAL(39)** onto the **LEFT CRANK(36)** and snap the **LEFT PEDAL STRAP(40)** onto the **LEFT PEDAL(39)**.

### STEP 12

Refer to the inset drawing. Plug the **PULSE SENSOR WIRE(73)** into the socket of **PULSE COIL WIRE(74)** located on the **SEAT CARRIAGE(64)**. Plug the **PULSE COIL WIRE(74)** into the socket of **PULSE CONNECTION WIRE(75)** located on the bracket on the **MAIN FRANE(1)**.

## ASSEMBLY INSTRUCTIONS

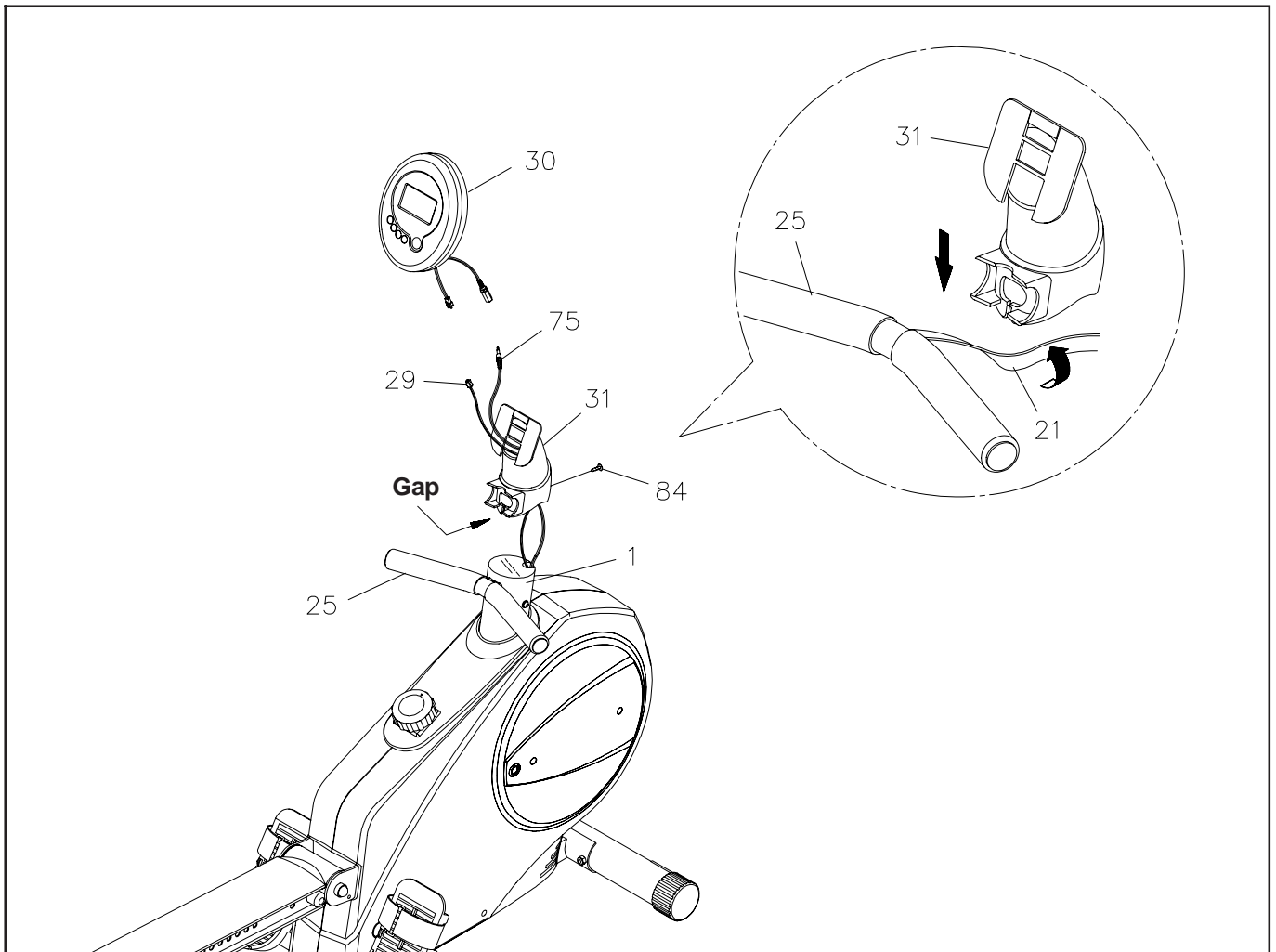

### STEP 13

Insert the **SENSOR WIRE(29)** and **PULSE CONNECTION WIRE(75)** into the bottom end of **METER POST(31)** and pull them out of the top of the **METER POST(31)**. Pull the **HANDLEBAR(25)**, twist the **STRAP(21)** and slide the strap thru the gap into the hole in the bottom of the **METER POST(31)**. Slide the **METER POST(31)** onto the **MAIN FRAME(1)** and secure with **SCREW(M5 X 18mm)(84)**.

### STEP 14

Install two "AA" batteries into the **METER(30)**, two batteries included. See page 11 for detailed battery installation instructions. Plug the **SENSOR WIRE(29)** and **PULSE CONNECTION WIRE(75)** to the **METER(30)** and push the excess wires back into the **METER POST(31)**. Place the **METER(30)** onto the plate on the **METER POST(31)**, then slide it down to lock in position.

**NOTE:** Please be careful not to damage the Sensor Wires when attaching the **METER(30)**.

## USING THE ELECTRONIC METER

**POWER ON:** Pedal movement or push the **MODE** button.

**POWER OFF:** Automatic shut off after 4 minutes of inactivity.

**MODE BUTTON:** Press and release to select functions.  
Press and hold for three seconds to reset all functions to zero, except **ODOMETER**.

### FUNCTIONS:

**SCAN:** Automatically scans **SPEED, DISTANCE, TIME, ODOMETER, CALORIE, and PULSE** in sequence with a change every six seconds. Press and release the **MODE** button until the arrow points to "**SCAN**".

**SPEED:** Displays the current speed, from zero to 999.9 Mile/Hr.

**DISTANCE:** Displays distance, from the time the meter is turned on, to 999.9 miles.

**TIME:** Displays the time, from 1 sec. up to 99:59 minutes.

**ODOMETER:** Displays the total accumulated distance you have traveled, from zero to 999.9 miles. The total accumulated distance is retained when the meter is turned off.

**CALORIE:** Displays the calorie consumption, from zero to 999.9 Kcal.

The calorie readout is an estimate for an average user. It should be used only as a comparison between workouts on this unit.

**PULSE:** Displays your pulse rate in beats per minute. To display pulse, select the PULSE MODE and grasp the pulse sensors on the handlebars, one in each hand. The heart icon will begin flashing when the ELECTRONIC METER senses your pulse. Your pulse will be displayed approximately five (5) seconds after the heart icon is displayed. If the heart icon does not appear, relax your grip or change your grip on the pulse sensors.

**NOTE:** 1. The function mark "**M**" in bottom-right on the LCD display means the electronics reading is in Miles. A "**K**" indicates Kilometers. To change the function mark from "**M**" to "**K**" or "**K**" to "**M**", press the **MODE** button and hold it down for five seconds until the second 2. beep.

The meter will shut off automatically after 4 minutes of inactivity. All function values will be kept. Press the **MODE** button and hold it down for three seconds to reset all functions to

3. zero, except **ODOMETER**.

The **ODOMETER** will be reset to zero after batteries are removed for battery replacement or storage of the unit.

### HOW TO INSTALL AND REPLACE BATTERIES:

1. Open the Battery Door on the back of the meter.
2. The meter operates with two AA batteries, two batteries included. Refer to the illustration to install or replace the batteries.

### NOTE:

1. Do not mix a new battery with an old battery.
2. Use the same type of battery. Do not mix an alkaline battery with another type of battery.
3. Rechargeable batteries are not recommended.

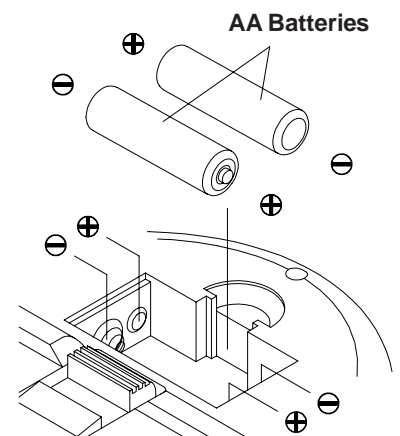
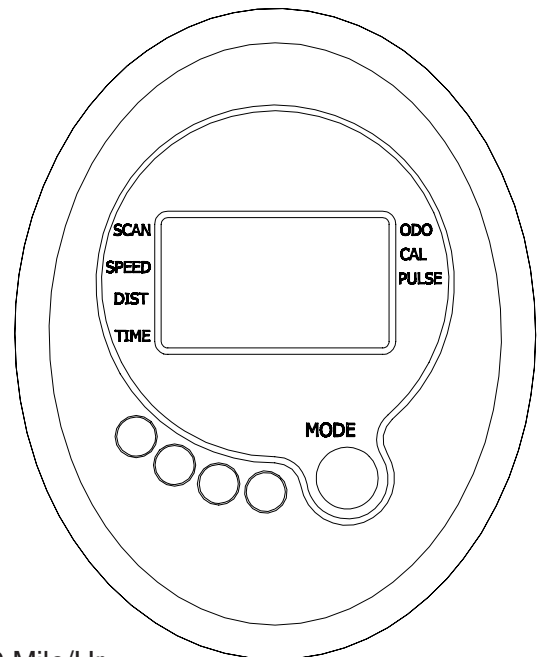

## OPERATIONAL INSTRUCTIONS

### RECUMBENT BIKE MODE AND ROWER MODE

Your **Conversion II™ 9002** can be used in the **Recumbent Bike** mode or the **Rower** mode. When the **SPRING PIN(67)** locks the **SEAT ASSEMBLY** to the **RAIL(52)**, the **Conversion II™ 9002** is in the **Recumbent Bike** mode. When the **SPRING PIN(67)** is in the Release position, the **SEAT ASSEMBLY** is not locked to the **RAIL(52)** and the **Conversion II™ 9002** is in the **Rower** mode.

**RECUMBENT BIKE MODE:** Pull the knob on the **SPRING PIN(67)**, turn it clockwise and release the knob to allow it to lock the seat in position. Sit on the seat and pedal with the **PEDALS(39, 41)**.

**ROWER MODE:** Pull the knob on the **SPRING PIN(67)** and turn it counter-clockwise to lock it in the release position. Refer to the inset drawing. This will allow the **SEAT ASSEMBLY** to slide freely on the **RAIL(52)**. To workout, sit on the seat, place your feet on the **FOOT PEDALS(46)** and pull on the **HANDLEBAR(25)**.

**NOTE:** If the **FRONT STABILIZER(2)** raises off the floor during use, adjust the **STAND(43)** to a higher position.

**CAUTION:** Always verify that the **SPRING PIN(67)** is in the correct position before you begin your workout.

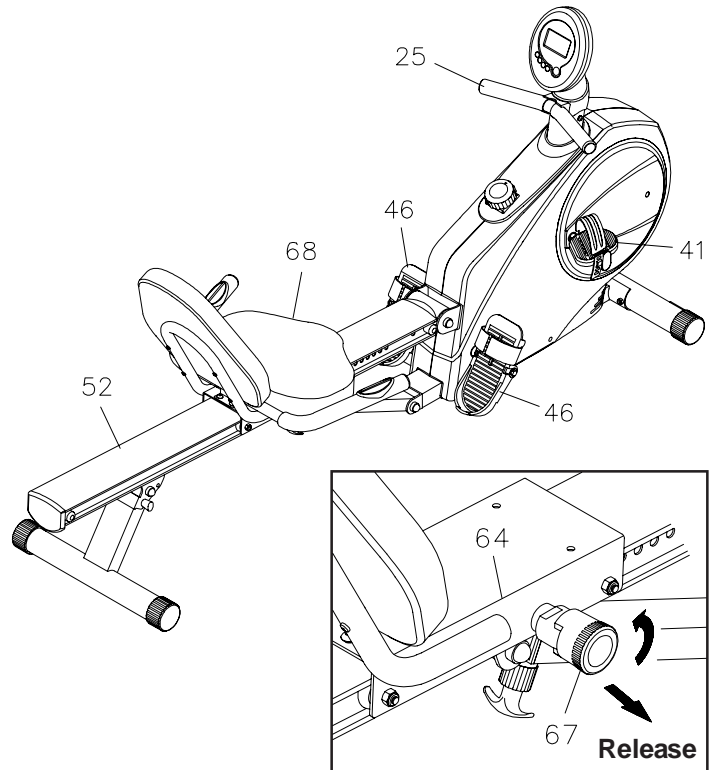

### SEAT ADJUSTMENT

Proper seat adjustment is important for **Recumbent Bike** mode.

1. Pull the knob on the **SPRING PIN(67)** and slide the **SEAT ASSEMBLY** forward or backward to adjust the seat. Release the knob on the **SPRING PIN(67)** and make sure it is inserted into one of the adjustment holes in the **RAIL(52)**.
2. Sit on the seat and place your feet on the pedals. You should be able to move through a complete pedal stroke without locking your knees or shifting your hips on the seat. The seat is too close to the pedals if you have more than a slight bend in your knees at the bottom of the pedal stroke. The seat is too far from the pedals if you have to completely straighten your knees at the bottom of the pedal stroke. Refer to the illustrations below.

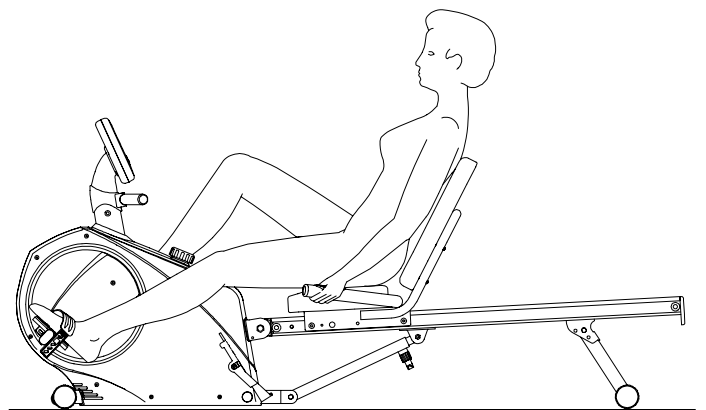

**WARNING:** Do not attempt to adjust the seat while you are on the **Conversion II™ 9002**.

---

## OPERATIONAL INSTRUCTIONS

### LOAD ADJUSTMENT

To increase the load, turn the **TENSION KNOB(27)** clockwise. To decrease the load, turn the **TENSION KNOB(27)** counterclockwise. There are eight levels for the load adjustment.

**NOTE:** The load will increase as you pedal faster.

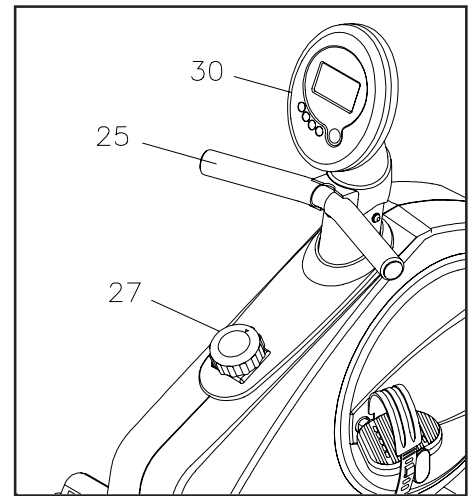

### MAINTENANCE

The safety and integrity designed into the **Conversion II™ 9002** can only be maintained when the **Conversion II™ 9002** is regularly examined for damage and wear. Special attention should be given to the following:

1. Adjust the **TENSION KNOB(27)** and verify that the Magnetic System provides tension. The Magnetic System should provide many years of use.
2. Clean the roller tracks in the **RAIL(52)** with an absorbent cloth.
3. It is the sole responsibility of the user/owner to ensure that regular maintenance is performed.
4. Verify that all nuts and bolts are present and properly tightened. Replace missing nuts and bolts. Tighten loose nuts and bolts.
5. Worn or damaged components shall be replaced immediately or the **Conversion II™ 9002** removed from service until repair is made.
6. Only Stamina Products supplied components shall be used to maintain/repair the **Conversion II™ 9002**.
7. **9002.**

Keep your **Conversion II™ 9002** clean by wiping with an absorbent cloth after use.

## STORAGE

1. To store the **Conversion II™ 9002** simply keep it in a clean dry place.
2. To avoid damage to the electronics meter, remove the batteries before storing the **Conversion II™ 9002** for one year or more.
3. Move the **Conversion II™ 9002** with the moving wheels on the Front Stand. Grasp the Rail Cap to move the **Conversion II™ 9002**. Do not use the Seat to move the **Conversion II™ 9002**. The Seat will move and the Seat Carriage may pinch your hand or fingers.
4. Follow the following process to fold The **Conversion II™ 9002** as illustrated for easy storage.
  - a. Adjust and lock the seat in position with at least one adjustment hole visible in front of the seat.  
**NOTE:** This will prevent the seat from damaging the covers.
  - b. Remove the **PULL PIN(63)** and swing the **REAR SUPPORT(62)** toward the front.  
**NOTE:** This will allow you to pull out the **RELEASE KNOB(59)** easily.
  - c. Pull out the **RELEASE KNOB(59)** and fold up the **RAIL(52)**. Make sure the **RAIL(52)** is locked securely in folded position by **RELEASE KNOB(59)**.
  - d. Lock the **REAR SUPPORT(61)** in folded position with the **PULL PIN(63)**.

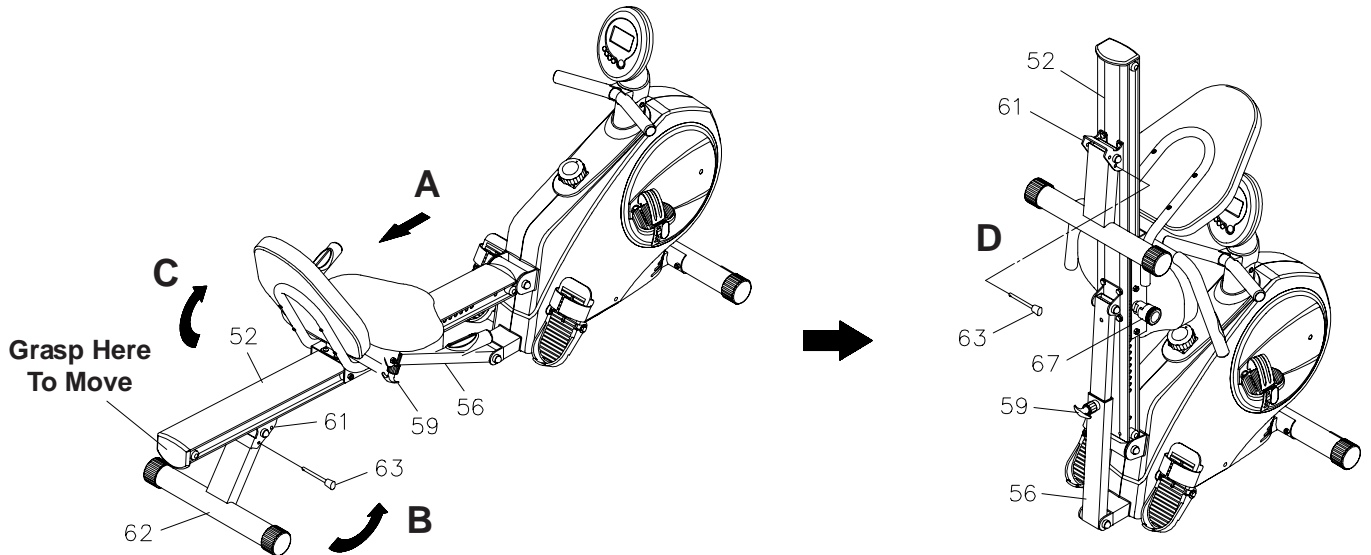

## UNFOLD THE Conversion II™ 9002

- a. Pull out the **RELEASE KNOB(59)** and unfold the **RAIL(52)**. Make sure the **RAIL(52)** is locked securely in the unfolded position by **RELEASE KNOB(59)**.
- b. Remove the **PULL PIN(63)** and swing the **REAR SUPPORT(62)** backward, then lock the **REAR SUPPORT(61)** in position with the **PULL PIN(63)**.

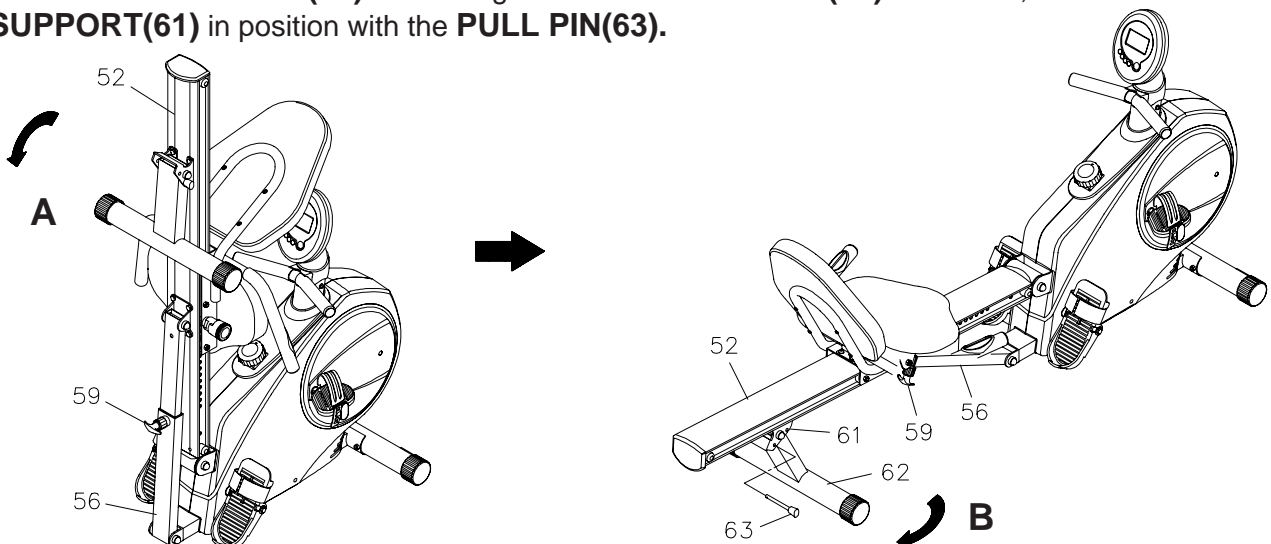

## CONDITIONING GUIDELINES

How you begin your exercise program depends on your physical condition. If you have been inactive for several years, or are severely overweight, you must start slowly and increase your time on the **Conversion II™ 9002** gradually: a few minutes per workout.

Initially, you may be able to exercise only for a few minutes in your target zone, however, your aerobic fitness will improve over the next six to eight weeks. Don't be discouraged if it takes longer. It's important to work at your own pace. Ultimately, you'll be able to exercise continuously for 30 minutes. The better your aerobic fitness, the harder you will have to work to stay in your target zone. Please remember these essentials:

- Have your doctor review your training and diet programs to advise you of a workout routine you should adopt.
- Begin your training program slowly with realistic goals that have been set by you and your doctor.
- Monitor your pulse frequently. Establish your target heart rate base on your age and condition.
- Set up your **Conversion II™ 9002** on a flat, even surface at least 3 feet from walls and furniture.

## EXERCISE INTENSITY

To maximize the benefits of exercising, it is important to exercise with the proper intensity. The proper intensity level can be found by using your heart rate as a guide. For effective aerobic exercise, your heart rate should be maintained at a level between 70% and 85% of your maximum heart rate as you exercise. This is known as your target zone. You can find your target zone in the table below. Target zones are listed for both unconditioned and conditioned persons according to age.

AGE	UNCONDITIONED TARGET ZONE (BEATS/MIN.)	CONDITIONED TARGET ZONE (BEATS/MIN.)
20	138~167	133~162
25	136~166	132~160
30	135~164	130~158
35	134~162	129~156
40	132~161	127~155
45	131~159	125~153
50	129~156	124~150
55	127~155	122~149
60	126~153	121~147
65	125~151	119~145
70	123~150	118~144
75	122~147	117~142
80	120~146	115~140
85	118~144	114~139

During the first few months of your exercise program, keep your heart rate near the low end of your target zone as you exercise. After a few months, your heart rate can be increased gradually until it is near the middle of your target zone as you exercise.

To measure your heart rate, stop exercising but continue moving your legs or walking around and place two fingers on your wrist. Take a six-second heartbeat count and multiply the results by 10 to find your heart rate. For example, if your six-second heartbeat count is 14, your heart rate is 140 beats per minute. (A six-second count is used because your heart rate will drop rapidly when you stop exercising.) Adjust the intensity of your exercise until your heart rate is at the proper level.

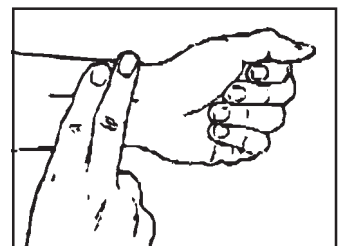

---

## WARM-UP and COOL-DOWN

**Warm-up** The purpose of warming up is to prepare your body for exercise and to minimize injuries. Warm up for two to five minutes before strength-training or aerobic exercising. Perform activities that raise your heart rate and warm the working muscles. Activities may include brisk walking, jogging, jumping jacks, jump rope, and running in place

**Stretching** Stretching while your muscles are warm after a proper warm-up and again after your strength or aerobic training session is very important. Muscles stretch more easily at these times because of their elevated temperature, which greatly reduces the risk of injury. Stretches should be held for 15 to 30 seconds. Do not bounce.

### Suggested Stretching Exercises

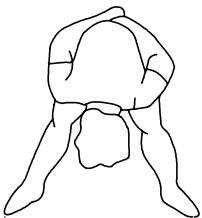

#### Lower Body Stretch

Place feet shoulder-width apart and lean forward. Keep this position for 30 seconds using the body as a natural weight to stretch the backs of the legs. **DO NOT BOUNCE!** When the pull on the back of the legs lessen, try a lower position gradually.

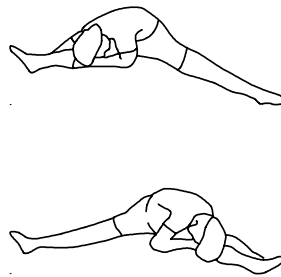

#### Floor Stretch

While sitting on the floor, open the legs as wide as possible. Stretch the upper body toward the knee on the right leg by using your arms to pull your chest to your thighs. Hold this stretch 10 to 30 seconds. **DO NOT BOUNCE!** Do this stretch 10 times. Repeat the stretch with the left leg.

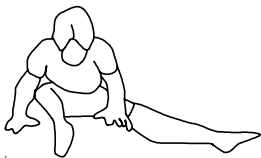

#### Bent Torso Pulls

While sitting on the floor, have legs apart one leg straight and one knee bent. Pull the chest down to touch the thigh on the leg that is bent and twist at the waist. Hold this position at least 10 seconds. Repeat 10 times on each side.

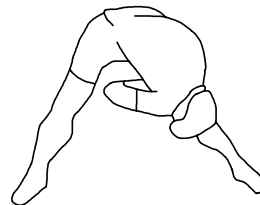
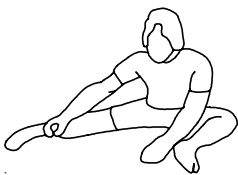

#### Bent Over Leg Stretch

Stand with feet shoulder-width apart and lean forward as illustrated. Using the arms, **gently** pull the upper body towards the right leg. Let the head hang down. **DO NOT BOUNCE!** Hold the position a minimum of 10 seconds. Repeat pulling the upper body to the left leg. Do this stretch several times slowly.

**Remember always to check with your physician before starting any exercise program.**

**Cool-Down** The purpose of cooling down is to return the body to its normal, or near normal, resting state at the end of each exercise session. A proper cool-down slowly lowers your heart rate and allows blood to return to the heart. Your cool-down should include the stretches listed above and should be completed after each strength-training session.

## WARRANTY

Stamina Products, Inc. warrants that this product will be free from defects in materials and workmanship under normal use, service and proper operation for a period of 90 days on the parts and three years on the frame from the date of the original purchase from an authorized retailer. **THIS WARRANTY SHALL NOT APPLY TO ANY PRODUCT WHICH HAS BEEN SUBJECT TO COMMERCIAL USE, ABUSE, MISUSE, ALTERATION OF ANY TYPE OR CAUSE OR TO ANY DEFECT OR DAMAGE CAUSED BY REPAIR, REPLACEMENT, SUBSTITUTION OR USE WITH PARTS OTHER THAN PARTS PROVIDED BY STAMINA PRODUCTS, INC.** Commercial use includes use of the product in athletic clubs, health clubs, spas, gymnasiums, exercise facilities, and other public or semipublic facilities whether or not the product's use is in furtherance of a profit making enterprise, and all other use which is not for personal, family, or household purposes.

To implement this limited warranty, send a written notice stating your name, date, and place of purchase and a brief description of the defect along with your receipt to **Stamina Products, Inc. P.O. Box 1071, Springfield Missouri, USA, 65801-1071** or call us at **1 (800) 375-7520**. If the defect is covered under this limited warranty, you will be requested to return the product or part to us for free repair or replacement at our option. **NO ACTION FOR BREACH OF THIS LIMITED WARRANTY MAY BE COMMENCED MORE THAN ONE (1) YEAR AFTER THE DATE THE ALLEGED BREACH WAS OR SHOULD HAVE BEEN DISCOVERED. NO ACTION FOR BREACH OF ANY IMPLIED WARRANTY MAY BE COMMENCED MORE THAN ONE (1) YEAR AFTER DELIVERY OF THE PRODUCT TO THE PURCHASER.** This limited warranty is not transferable. **IF ANY PART OF THE PRODUCT IS NOT IN COMPLIANCE WITH THIS LIMITED WARRANTY OR ANY IMPLIED WARRANTY, THE REMEDY OF REPAIR OR REPLACEMENT IS THE EXCLUSIVE REMEDY AVAILABLE TO YOU.** In the event that the purchaser makes any claim under this limited warranty or any implied warranty, the Warrantor reserves the right to require the product to be returned for inspection, at the purchaser's expense, to the Warrantor's premises in Springfield, Missouri. Return of the enclosed warranty registration card is not required for warranty coverage, but is merely a way of establishing the date and place of purchase.

Stamina Products, Inc. **SHALL NOT BE LIABLE FOR THE LOSS OF USE OF ANY PRODUCT, LOSS OF TIME, INCONVENIENCE, COMMERCIAL LOSS OR ANY OTHER INDIRECT, CONSEQUENTIAL, SPECIAL OR INCIDENTAL DAMAGES DUE TO BREACH OF THE ABOVE WARRANTY OR ANY IMPLIED WARRANTY.**

This limited warranty is the only written or express warranty given by Stamina Products, Inc. This warranty gives you specific legal rights, and you may also have other legal rights which vary from state to state. **ANY OTHER RIGHT WHICH YOU MAY HAVE, INCLUDING ANY IMPLIED WARRANTY OR MERCHANTABILITY OR FITNESS FOR A PARTICULAR PURPOSE, IS LIMITED IN DURATION TO THE DURATION OF THIS WARRANTY.**

The laws in some jurisdictions restrict the rights of manufacturers and distributors of consumer goods to disclaim or limit implied warranties and consequential and incidental damages with respect thereto. If any such law is found to be applicable, the foregoing disclaimers and limitations of and on implied warranties and consequential and incidental damages with respect thereto shall be disregarded and shall be deemed not to have been made to the extent necessary to comply with such legal restriction.

# PRODUCT PARTS DRAWING

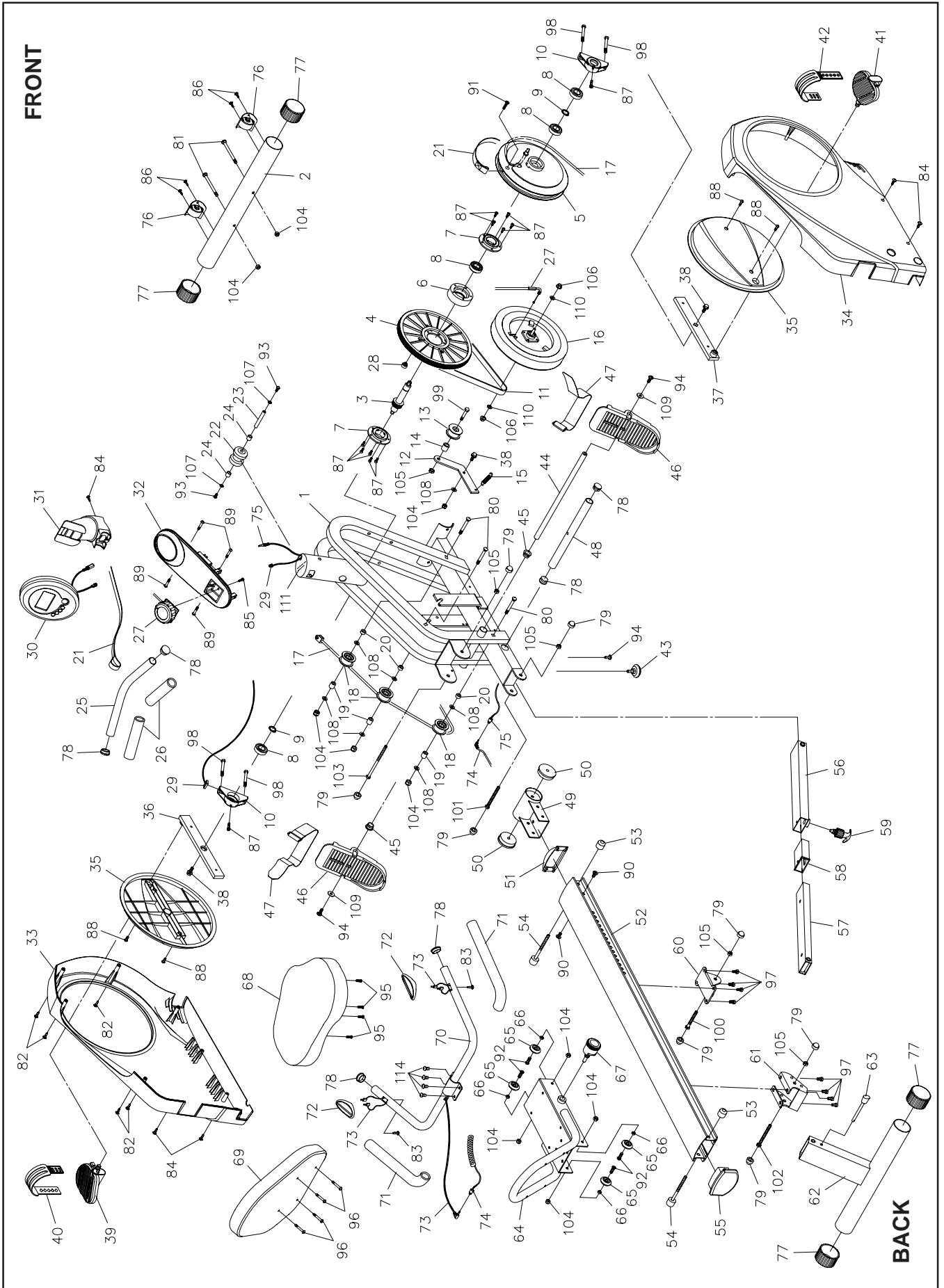

---

## PARTS LIST

DIAGRAM#	PART NAME	QTY
1	Main Frame	1
2	Front Stabilizer	1
3	Axle	1
4	Pulley	1
5	Strap Wheel	1
6	Connection Wheel	1
7	Free Wheel	2
8	Bearing (6004 zz)	4
9	C Ring (M20)	2
10	Bearing Housing	2
11	V-Ribbed Belt	1
12	Idler Arm	1
13	Idler Wheel	1
14	Idler Wheel Spacer	1
15	Tension Spring	1
16	Magnetic System	1
17	Bungee Cord	1
18	Bungee wheel	3
19	Wheel Bushing	3
20	Wheel Spacer	3
21	Strap	1
22	Strap Roller	1
23	Roller Axle	1
24	Roller Spacer	2
25	Handlebar	1
26	Foam Grip	2
27	Tension Knob	1
28	Magnet	1
29	Sensor Wire	1
30	Meter	1
31	Meter Post	1
32	Top Cover	1
33	Left Cover	1
34	Right Cover	1
35	Crank Cover	2
36	Left Crank	1
37	Right Crank	1
38	Flange Bolt (M8 x 1.25 x 25mm)	3
39	Left Pedal	1
40	Left Pedal Strap	1
41	Right Pedal	1
42	Right Pedal Strap	1
43	Stand	1
44	Pedal Shaft	1
45	Spacer	2
46	Foot Pedal	2
47	Pedal Strap	2
48	Stopper Tube	1
49	Rail Pivot	1
50	Pivot Bushing	2
51	Rail Connection Cap	1
52	Rail	1
53	Stopper	2
54	Stopper Bolt	2
55	Rail Cap	1
56	Support Tube	1
57	Inner Support Tube	1

## PARTS LIST

DIAGRAM#	PART NAME	QTY
58	Bushing	1
59	Release Knob	1
60	Support Bracket	1
61	Rear Support Bracket	1
62	Rear Support	1
63	Pull Pin	1
64	Seat Carriage	1
65	Seat Roller	4
66	Seat Roller Spacer (ø8 x ø12 x 6.5mm)	4
67	Spring Pin	1
68	Seat	1
69	Back Cushion	1
70	Handrail	1
71	Foam Grip	2
72	Pulse Sensor Plate	2
73	Pulse Sensor Wire	1
74	Pulse Coil Wire	1
75	Pulse Connection Wire	1
76	Moving Wheel	2
77	Round Endcap (60mm)	4
78	Round Plug (25mm)	6
79	Nut Cap (M10)	8
80	Carriage Bolt (M8 x 1.25 x 60mm)	3
81	Carriage Bolt (M8 x 1.25 x 70mm)	2
82	Screw, Round Head (M4 x 20mm)	5
83	Screw, Round Head (M4 x 25mm)	2
84	Screw, Round Head (M5 x 18mm)	5
85	Screw, Round Head (M5 x 0.8 x 15mm)	1
86	Screw, Round Head (M5 x 0.8 x 18mm)	4
87	Bolt, Socket Head (M5 x 0.8 x 15mm)	12
88	Bolt, Round Head (M6 x 1 x 15mm)	4
89	Bolt, Round Head (M6 x 1 x 30mm)	4
90	Bolt, Flat Head (M8 x 1.25 x 16mm)	2
91	Bolt, Flat Head (M8 x 1.25 x 25mm)	1
92	Bolt, Flat Button Head (M8 x 1.25 x 25mm)	4
93	Bolt, Button Head (M6 x 1 x 12mm)	2
94	Bolt, Button Head (M8 x 1.25 x 15mm)	3
95	Bolt, Hex Head (M6 x 1 x 15mm)	4
96	Bolt, Hex Head (M6 x 1 x 30mm)	4
97	Bolt, Hex Head (M8 x 1.25 x 16mm)	8
98	Bolt, Hex Head (M8 x 1.25 x 55mm)	4
99	Bolt, Hex Head (M10 x 1.5 x 45mm)	1
100	Bolt, Hex Head (M10 x 1.5 x 75mm)	1
101	Bolt, Hex Head (M10 x 1.5 x 85mm)	1
102	Bolt, Hex Head (M10 x 1.5 x 95mm)	1
103	Bolt, Hex Head (M10 x 1.5 x 125mm)	1
104	Nylock Nut (M8 x 1.25)	10
105	Nylock Nut (M10 x 1.5)	5
106	Flange Nut (M10 x 1.25)	2
107	Washer (M6)	2
108	Washer (M8 x ø16 )	7
109	Large Washer (M8 x ø23 )	2
110	Washer (M10)	2
111	Decal	1
112	Allen Wrench (6mm)	2
113	Manual	1
114	Bolt, Button Head (M8 x 1.25 x 12mm)	4

---

## NOTES

