



Assembly Manual

ASSEMBLY

Your WaterRower comes partially assembled in two boxes for protection during transit and for economy of shipment.

Assembling your WaterRower should take about half an hour. The tools you will need have been provided.

We have all experienced the frustrations caused by incomprehensible assembly instructions. For this reason we have gone to added effort to make our instructions as clear and concise as possible. Do not be intimidated by the detail:- it is simply intended to make the assembly process as comfortable as possible for you.

STEP ONE

Lay the rails on the floor, and connect the rear spacer using the male JCN nuts and the allen key provided.

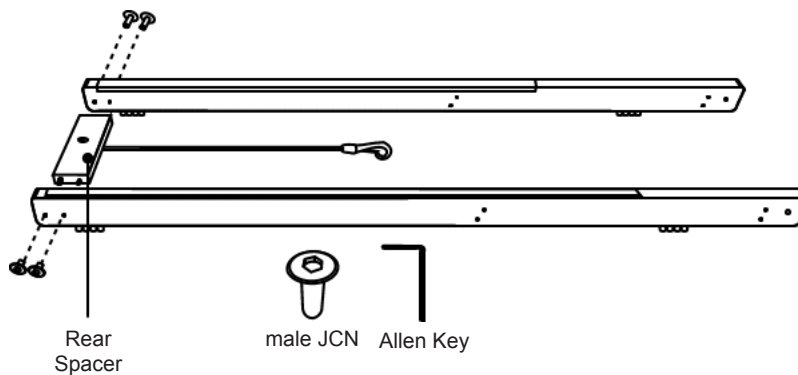

STEP TWO

Sit the seat between the rails. Note the orientation of the seat with the indent facing the rear. It may be necessary to separate the rails slightly to allow the seat to sit into place.

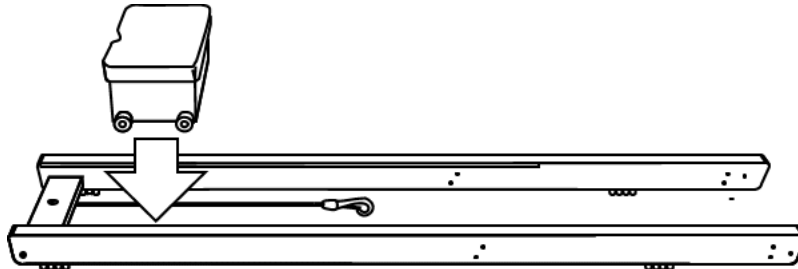

STEP THREE

Place the tank assembly between the rails.

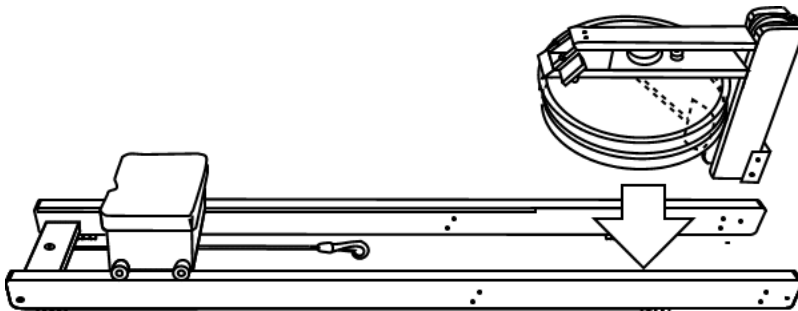

WaterRower



Assembly

STEP FOUR

Place the footboard between the rails positioning the top two holes over the two threaded holes in the black tank unit. Screw the handle rests into position using the handle rest bolts. It may be necessary to slightly loosen the two bolts on the top deck (A) to allow the footboard clearance.

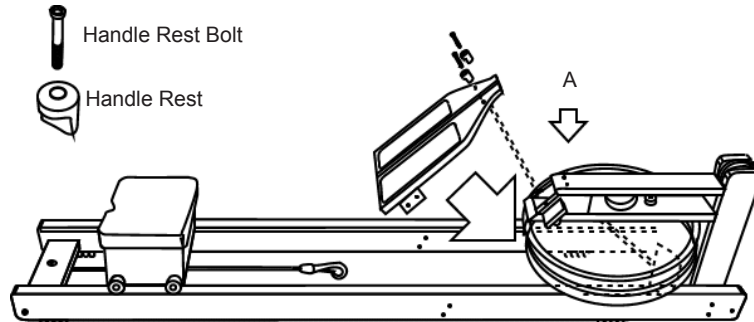

STEP FIVE

Insert the JCN nuts and JCB Bolts attaching the tank and the footboard to the rails at A & B. The nuts should be placed on the inside and the bolts on the outside. Should you experience any problem with aligning the components, loosen all the fasteners align and retighten.

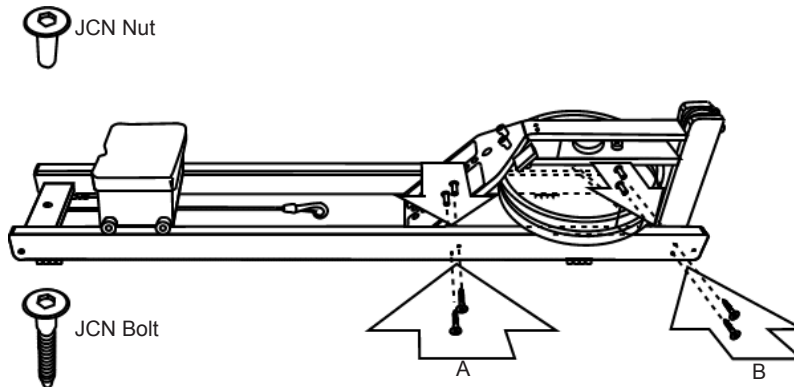

WaterRower



Assembly

STEP SIX

Bolt the heel rest onto the footboard. The position of the heel rest can be varied by placing it in any of the three positions defined by the rows of holes in the footboard. (see section on Heel Rest and Footstrap Position).

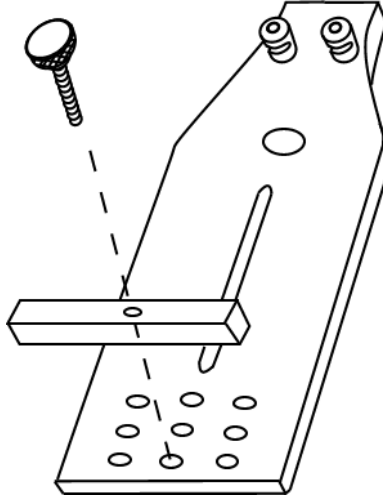

STEP SEVEN

Bolt the footstrap to the footboard as shown below. The strap should pass between the back of the footboard and the rear clamp plate to stop the footstrap moving up and down. The height at which the footstrap sits may be adjusted for different foot sizes and heel rest positions. (see section on Heel Rest and Footstrap Position).

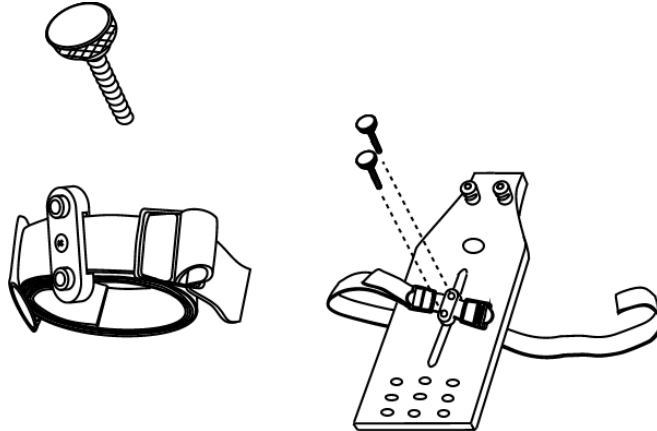

WaterRower



Assembly

STEP EIGHT

Undo the Dolley Wheel assembly and fix to the rail in the order shown and tighten with the allen key provided.

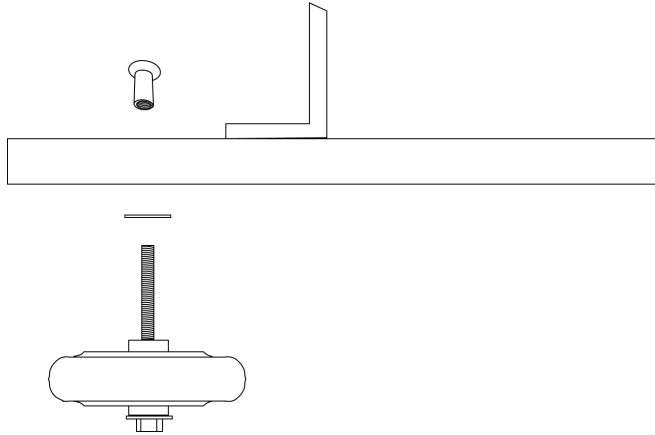

STEP NINE

Stand the WaterRower upright and connect the bungee to the recoil strap

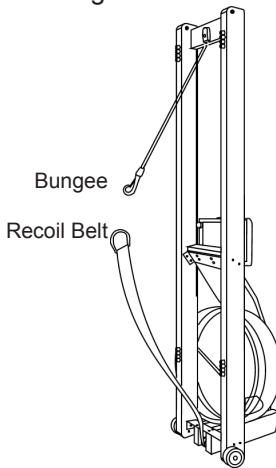

STEP TEN

Lay the WaterRower down and fill the tank to the desired level (see section on Water Level). Insert the stopper, your WaterRower is now ready for use.

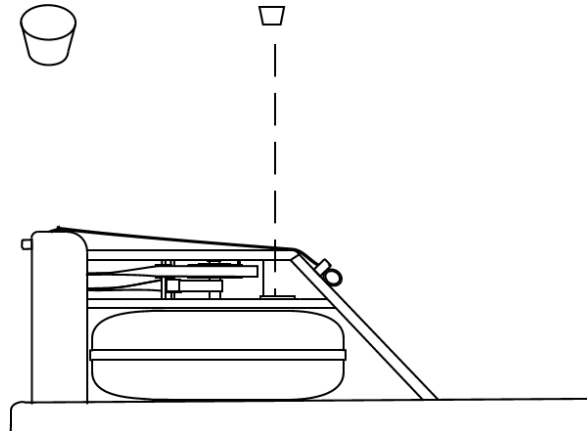

WaterRower



Warranty

Private Use- WaterRower Inc. (WaterRower) will replace or repair at its factory or nominated service centre any WaterRower or WaterRower component found to be defective in material or workmanship for a period of THREE (3) YEARS from the date of initial shipment by WaterRower.

Commercial Use- WaterRower Inc. (WaterRower) will replace or repair at its factory or nominated service centre any WaterRower or WaterRower component found to be defective in material or workmanship for a period of ONE (1) YEAR from the date of initial shipment by WaterRower.

This warranty will be invalid if in the opinion of WaterRower the claim has been caused by: (a) accident, abuse, misuse, misapplication or as a result of any modification other than by WaterRower; (b) deterioration due to normal wear and tear (c) improper preventive maintenance steps as described in the WaterRower manual.

Return of the WaterRower or WaterRower component to WaterRower's factory or nominated service centre will be the responsibility of the claimant.

The WaterRower or component should be packed to protect it from damage, WaterRower will not be responsible for any damage which may occur during shipment. Postage should be prepaid and the package should contain the claimant's name, address and telephone number, a description of the problem, and proof of purchase.

WaterRower will return the WaterRower or WaterRower component to the claimant at its (WaterRower's) expense except in the case where the warranty has been deemed invalid. In the event that the warranty is found to have been invalidated, then the costs of such investigation, repair and any associated shipping costs shall be borne by the claimant.

This warranty is not transferable. Should ownership of the WaterRower be transferred then the warranty may be transferred at additional cost. WaterRower warrants against any defective WaterRower spare part received from WaterRower or any authorized dealer for a period of NINETY (90) DAYS after the date of shipment.

WaterRower Inc. shall not be liable for any direct, consequential, incidental indirect or special damages under this warranty, or any implied warranty.

The warranty described in this paragraph shall be in lieu of any other warranty, express or implied, including but not limited to, any implied warranty of merchantability or fitness for a particular purpose.

The term of this warranty does not affect or prejudice the statutory rights of a consumer, neither does it limit or exclude any liability for death or personal injury caused by WaterRower's negligence.

WaterRower

America: 30 Cutler St, Warren, RI, +1 401 247 7742, support@waterrower.com, www.waterrower.com
Europe: 5 Goldhawk Estate, Brackbury Rd, London, +44 020 8749 8400, support@waterrower.co.uk, www.waterrower.co.uk