

Owners Manual

FIRST  **DEGREE**
FITNESS

Fluid **FR-E316**

Training with the E-316

1. As with any piece of fitness equipment, consult a physician before beginning your E-316 exercise program.
2. Follow instructions provided in this manual for correct foot position and basic rowing techniques.

CAUTION

1. The E-316 can stand vertically for storage. When doing so, please follow the instructions given on the basic operation section of this manual.

CAUTION

2. Keep hands away from moving parts, as indicated by the warning sticker on the mainframe of your machine and inside the PVC rear cover.

Contents

1. Contents of E-316 Pack.
2. E-316 assembly instructions.
3. Tank filling and water treatment.
4. How to row.
5. Long term water treatment and basic operation.
6. Maintenance chart.
7. Troubleshooting guide.
8. The 316 Rower Ergometer.
9. Changing the bungee cord.
10. Parts list and Warranty.

E-316 Box Contents

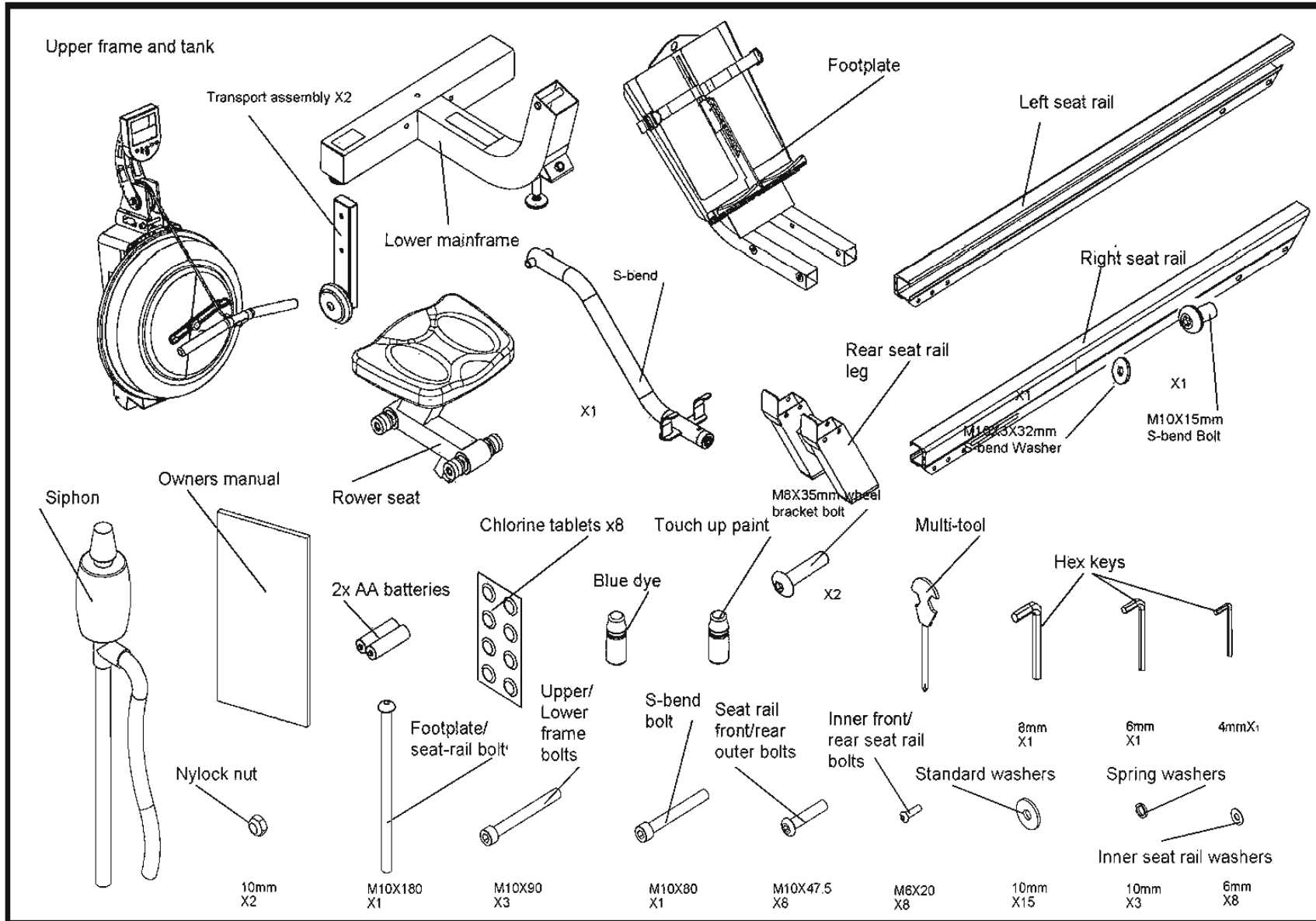

E-316 Assembly Instructions

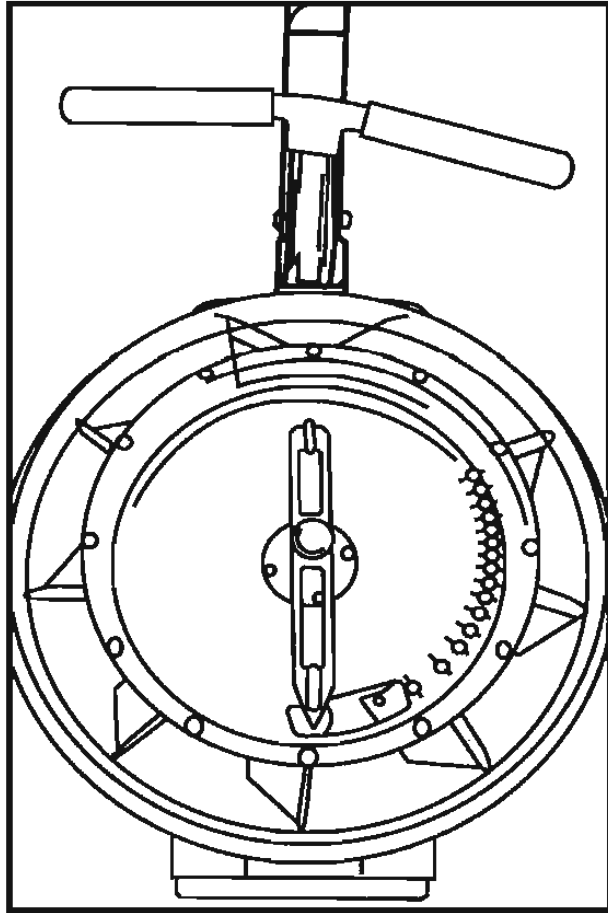

Step 1. Remove contents from box, and lay upper frame (tank assembly) on its back.

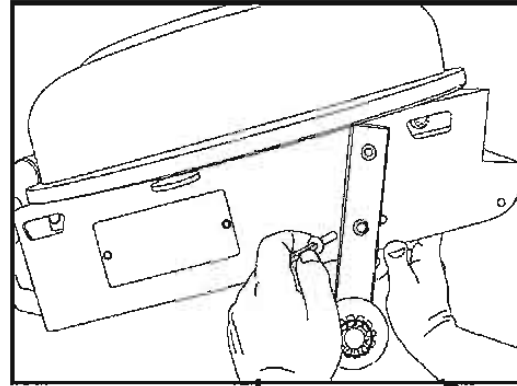

Step 2. Tilt slightly to one side and allow transport wheels to drop into position. Secure with M8x35mm bolt. Repeat on opposite side.

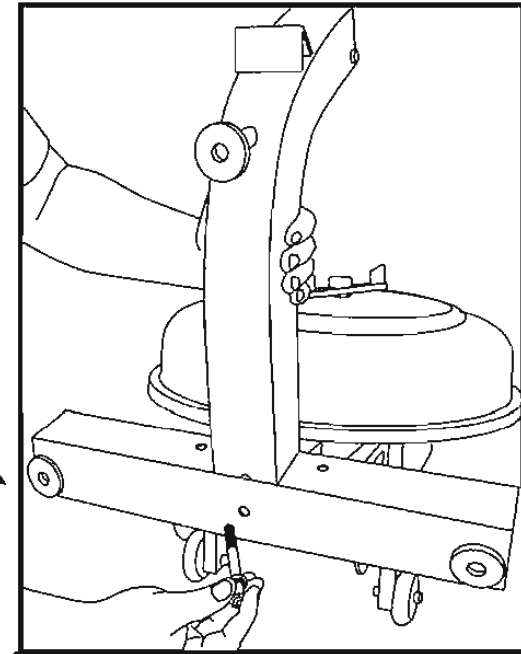

Step 3. Attach lower frame to upper frame with center bolt (M10X90mm bolt and spring washer) but do not tighten.

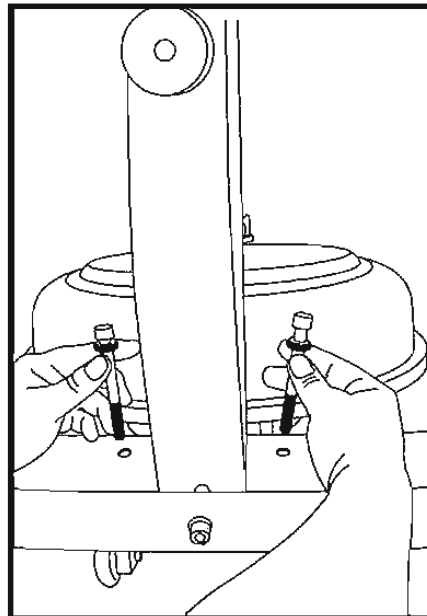

Step 4. Install left and right side bolts (M10X90mm bolt and spring washer). Tighten all three.



WARNING



Keep hands clear of pivoting parts during assembly.

E-316 Assembly Instructions

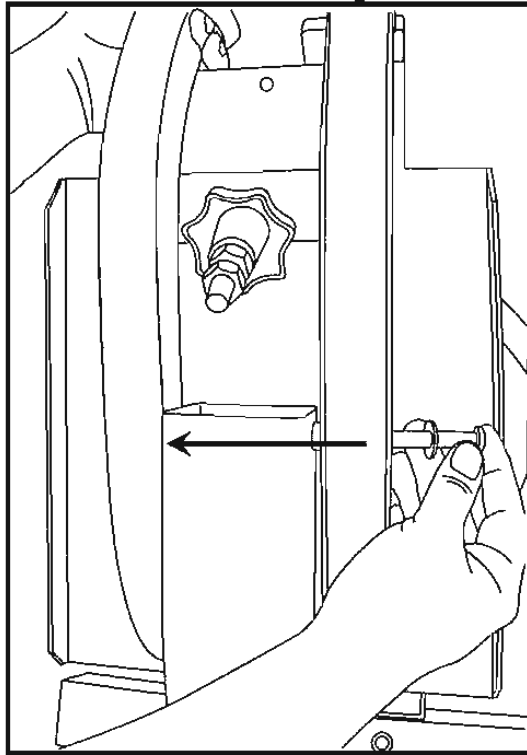

Step 5. Attach the footplate to the main frame (M10X180mm bolt, M10 Nylock nut and 2 washers). Caution: The footplate is heavy, FDF recommends two people for this section of assembly.

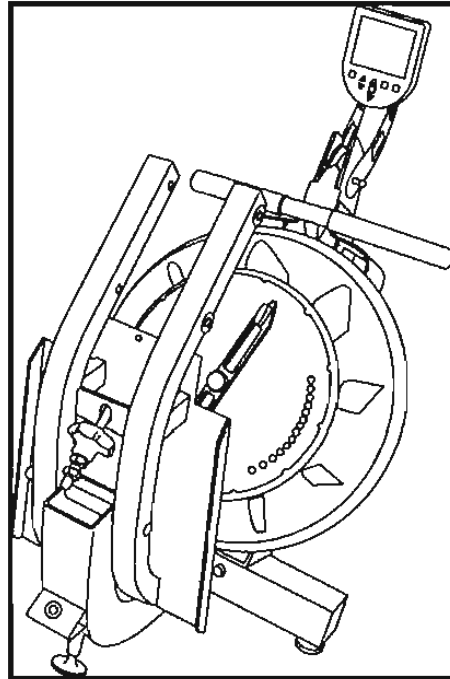

Note: Once footplate is secured, the assembly can be continued from this position for added stability.

! WARNING !

Keep hands clear of pivoting parts during assembly.

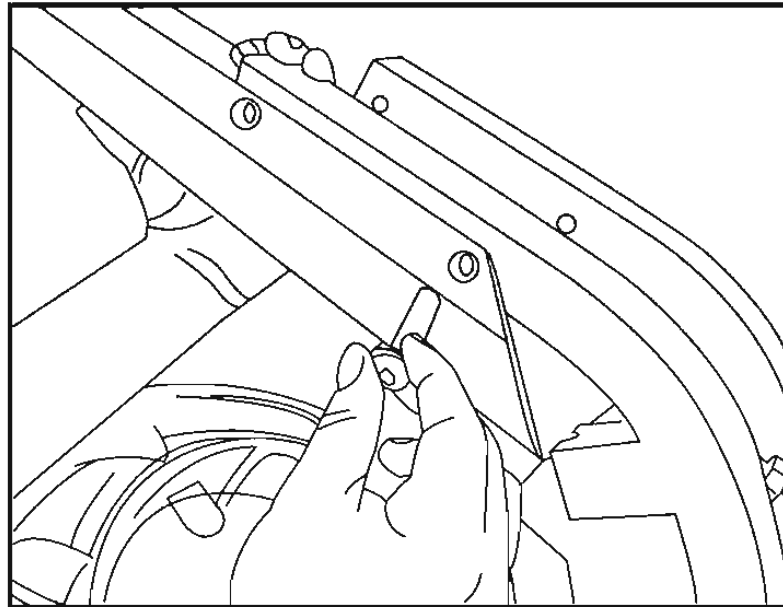

Step 6. Attach the seat rails to the footplate using M10X47.5 bolts, M6X20 bolts, screws and 4x10mm/4x6mm washers.

Assembly Instructions

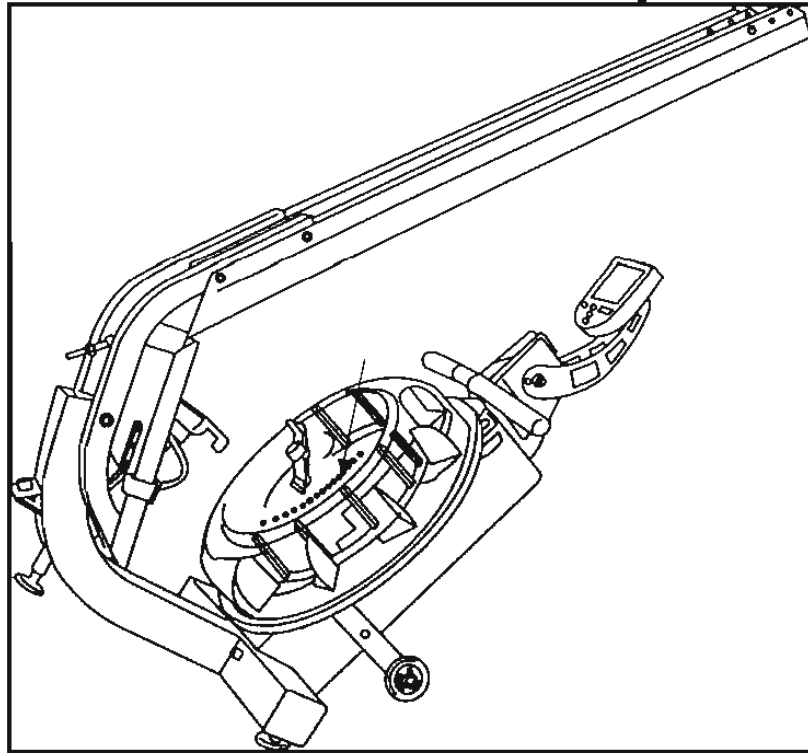

Note: Once seat rails are attached, continue assembly from this position for stability.

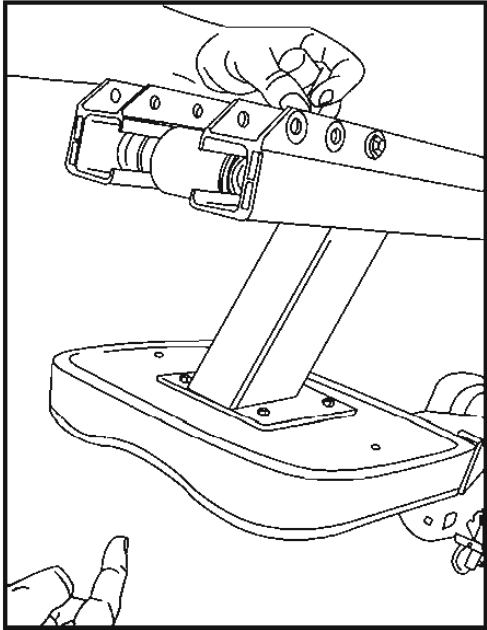

Step 7. Install the rower seat with seat indentation facing rearward.

Caution: The E-316 rower seat is heavy, use care when guiding down the seat rails.

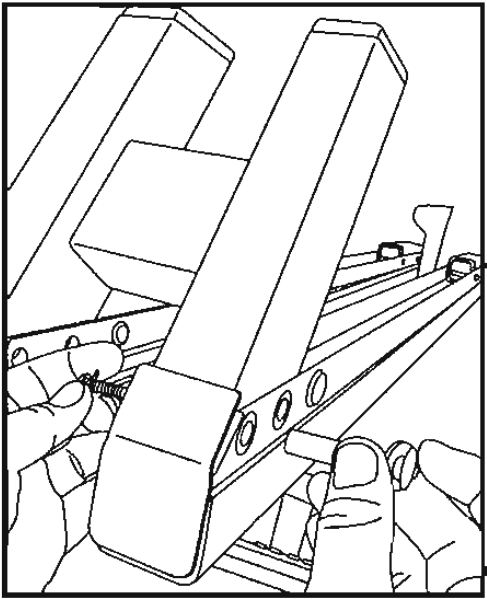

Step 8. Install the rear leg assembly to the seat rails using M10X47.5 bolts, M6X20 Allen key screws and 4x10mm/4x6mm washers.

Assembly Instructions

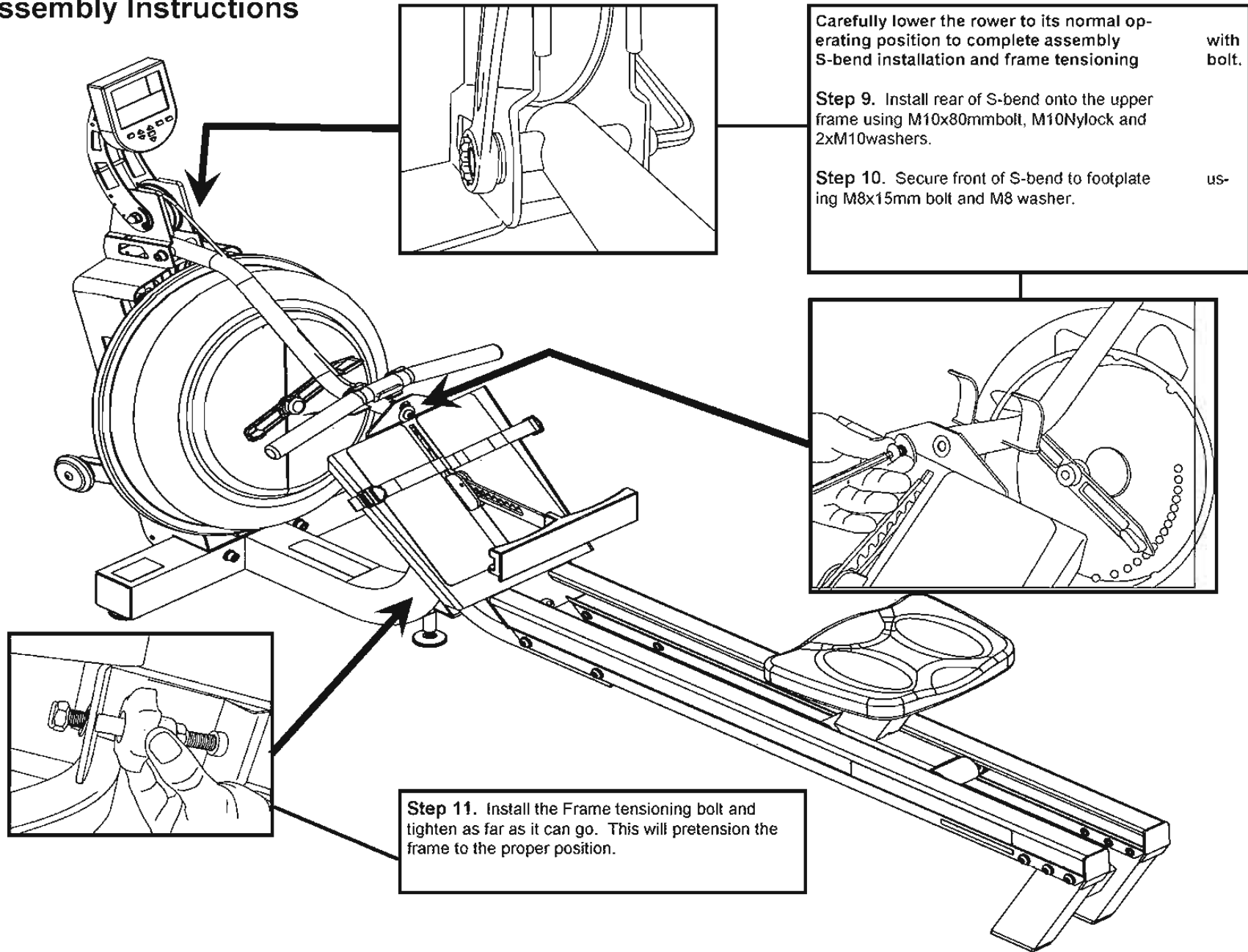

Carefully lower the rower to its normal operating position to complete assembly S-bend installation and frame tensioning with bolt.

Step 9. Install rear of S-bend onto the upper frame using M10x80mm bolt, M10Nylock and 2xM10washers.

Step 10. Secure front of S-bend to footplate using M8x15mm bolt and M8 washer. us-

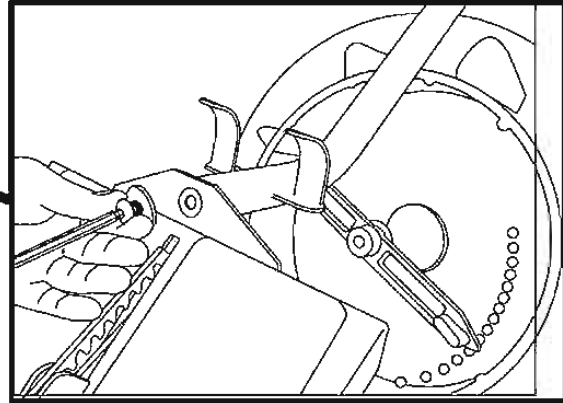

Step 11. Install the Frame tensioning bolt and tighten as far as it can go. This will pretension the frame to the proper position.

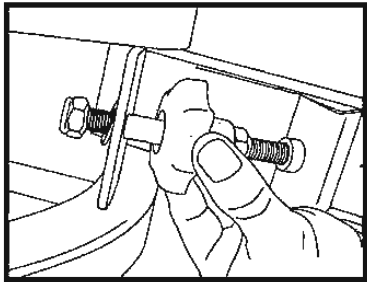

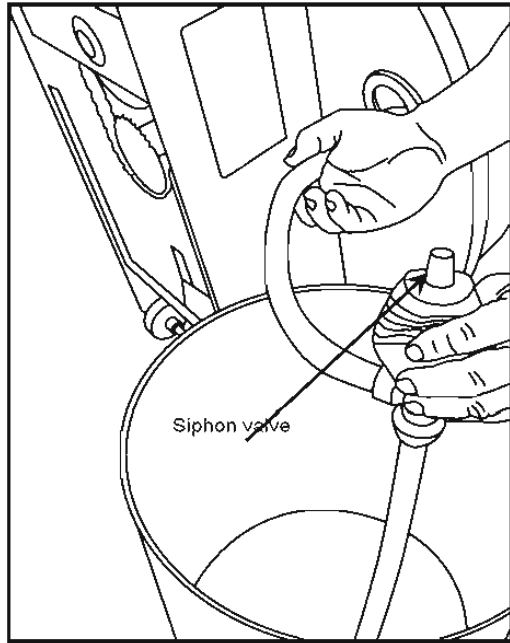

Fill tank as shown left. Use the right plug only for filling.

Fill with adjuster handle at level 16 only.

Once filling is complete, use a coin or large blade screwdriver to tighten tank plug into place.

Tank filling and Water Treatment

1. Filling requires a large bucket (not supplied) and the Fluid Rower siphon (included). Filling will take approximately 7.6 liters of water.
2. Unscrew the right tank plug on the rear of the fluid tank and insert the flexible tube into the rear of the tank while keeping the rigid hose in the bucket. Note: The siphon tube may be impeded by one of the impeller blades. Use the siphon only to push the impeller down slightly.

Warning: Do not insert fingers into tank.

3. Move the adjuster handle to level 16, and begin filling. Note: The siphon valve must be closed to allow siphoning action to occur. Tip: Placing the bucket in an elevated position will allow the siphon to continually pump water into the tank. Do not fill past the calibration mark indicated on the tank!

Note: Opening the siphon valve will stop the pumping action. Use this feature to avoid water spillage when nearing filling completion.

4. Once filling is complete (to the proper calibration level as indicated on the tank), follow water treatment schedule as shown.

Caution: Use a drop cloth under the tank both when filling the tank and adding blue dye to avoid staining floor or carpet



Water Treatment Procedures:

1. Add Chlorine tablet.
2. Wait a minimum of 72 hours. Then add very small amount of blue dye and check for desired color. **Important! Do not add blue dye for at least 72 hours following Chlorine treatment.** The blue dye adds visual appeal as well as cutting down the amount of light affecting the tank water, thus extending the amount of time between water treatments.

Blue dye

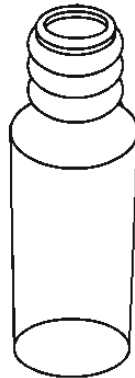
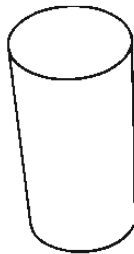

How to row.

1. Begin the stroke comfortably forward and push strongly back with your legs while keeping your arms and back straight.
2. Begin to pull your arms back as they pass over your knees and continue the stroke through to completion rocking slightly back over your pelvis.
3. Return to the starting position and repeat.



How often?

Begin with 5 minute training sessions once a day and aim for around 2:30 to 2:45 for 500m time. Row at a pace that keeps the water circulating continuously between strokes.

Progress a few minutes more each day until you are comfortable with 30-45 minutes training time 3 or 4 times a week.

This is sufficient to provide aerobic endurance benefits, muscle toning and sufficient calorie burning to form part of a weight loss program.

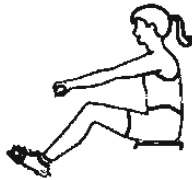
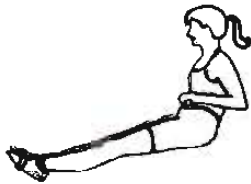
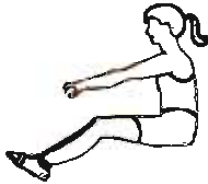
	CAUTION
	Always consult a doctor before beginning an exercise program. Stop immediately if you feel faint or dizzy.

				
Catch Comfortably forward with straight back and arms.	Drive Push with the legs while arms remain straight.	Finish Pull through with arms and legs rocking slightly back on your pelvis.	Recovery Upper body tips forward over your pelvis and move forward.	Catch Catch and begin again.

Long term water treatment and basic operation

	CAUTION

Important: Do not fill past the calibration mark as indicated on the tank level sticker or water spillage may occur. See tank filling/water treatment page for details.

Long term water treatment:

Do not use any water treatment other than the tablets supplied with this machine. For replacement tablets, contact your local First Degree Fitness distributor.

Water treatment schedules for the E-316 will vary according to the fluid tanks exposure to sunlight, but expect 8-12 months near a bright, sunlit window and 2 years or more for a darker location. At the point of finding the water slightly cloudy, add a Chlorine tablet. Remember to wait 72 hours following the chlorine tablet before adding the blue dye as the Chlorine tablet is extremely concentrated.

Caution: It is critical that a drop cloth be used under the fluid tank whenever the tank plug is opened for water treatment.



Vertical storage: The E-316 can easily be stored in a vertical, upright position. For safety, choose a suitable location, such as a corner of a room. It is recommended that something soft (such as carpet or a small towel) be placed under the upper rear of the unit to avoid marring either the paint or Perspex cover.

Resistance:

The level of resistance is determined by the level indicator located on the front of the tank. Level one indicates lightest resistance, level sixteen represents heaviest resistance. Allow three to four strokes after adjusting resistance handle for the correct resistance level to be achieved.

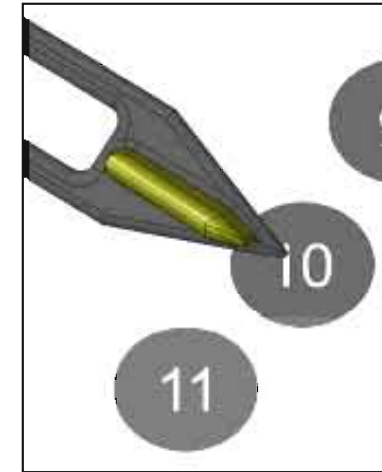

Dyneema Rope:

The unique Dyneema rope drive system allows for simplicity and unparalleled performance. The properties of Dyneema make it extremely useful in harsh environments, such as sailing, climbing, fishing lines, body armor, etc. It is quite literally stronger than steel.

Note If the Dyneema rope is twisted excessively, the return will feel lumpy. Use the rower handle to untwist the rope to its normal operating position.

Light fraying is normal. The Dyneema may have a slight "fuzzy" appearance after a period of usage. It is normal for this material. Dyneema is very abrasion resistant and to some degree self-lubricating. Expect many years of trouble free performance.

Heel support adjuster:

The E-316 has a unique and easy to use Heel plate Support system. Simply slide the Heel plate up or down to the required position and allow the teeth to lock it into place. This should place the ball of your foot directly under the horizontal foot Straps. Secure Foot Straps.

Maintenance chart.

Item	Timeframe	Instructions	Notes
Seat and seat rails.	Weekly.	Wipe seat rails with lint free cloth. Spray seat rails with a light coat of silicone spray.	
Frame.	Weekly.	Wipe down with lint free cloth.	
Tank and water treatment.	12 months to 2 years.	Follow instructions as specified in the "Water Treatment" section of this manual.	
Bungee cord.	Check every hundred hours for correct tension and for signs of wear.	The bungee cord should last for many years. If a bungee cord change is required, please follow the instructions provided in the "Changing the bungee cord" section of this manual.	
Dyneema Rowing Rope.	Check monthly for signs of twisting, excess fraying or other signs of premature wear. Note that a light "fuzz" is perfectly normal for Dyneema rope and will not affect performance or longevity in any way.	The Dyneema rowing rope should rarely require changing, but should the need arise, please follow the instructions provided in the "Changing the Dyneema rope" section of in the service section of the First Degree Fitness website at www.firstdegreefitness.com	

Troubleshooting Guide

Fault	Probable Cause	Solution
Water changes color or becomes cloudy.	Rower is in direct sunlight or has not had water treatment.	Change rower location to reduce direct exposure to sunlight. Add water treatment and blue dye or change tank water as directed in the water treatment section of this manual.
Rowing stroke return is too light.	Bungee not under enough tension.	Open rear Perspex cover, cut bungee tie wrap . Tighten by small increments using the bungee tie off tab point and test tension by allowing the rowing handle to return to its furthest point forward while still having some slight tension. Note light fraying of the bungee cord is normal.
Rower rocks from side to side when sitting on floor	Front/Rear frame levelers need adjusting	Adjust the front two frame levelers or rear leg levelers until stability is reached. Note: It is normal for the lower rear leveler to rest slightly off the floor.
Front of rower lifts slightly during vigorous rowing.	Lower rear frame leveler too high.	Check to see that frame tensioning bolt is tightened properly. Lower rear frame leveler should be approx 5mm off the ground.
Computer screen illuminates, but does not register when rowing.	Loose or failed connection/Sensor gap too wide (see erratic computer display).	Check that the computer lead is connected properly. If connected properly check sensor gap. Contact your local service center if this fails to address the problem.
Rowing stroke feels lumpy, not smooth..	Dyneema rope is twisted .	You can untwist the Dyneema rope by simply pulling the rowing handle to the end and turning the rowing handle to untwist the rope. Note: Light fraying is normal.
The E-316 computer does not illuminate after battery installation.	Batteries installed incorrectly or need replacing.	Reinstall batteries in correct position and try again. If the LCD screen fails to illuminate, try rotating the batteries slightly in the computer. If this fails, contact your local service center.
The E-316 computer display is erratic while displaying SPM and 500meter times.	Gap between sensor and magnetic ring is too wide.	Adjust sensor location using rear sliding adjustment located inside rear Perspex cover.

E-316 Rower Ergometer.

Quick start provides instant workout information. Just start training to activate. You can choose to change UNITS displayed.

UNITS displays
WATTS, SPM, HR, 500/m

Level Adjustable
from 1-16

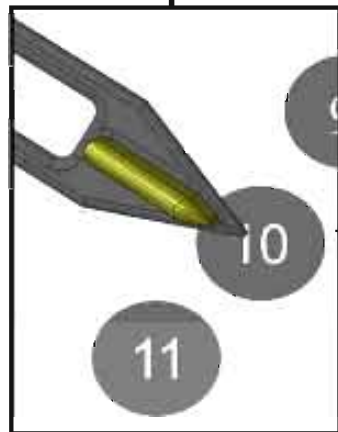

Set Changes Time, Distance parameters

Note: For complete operational instructions, please refer to the computer manual, which is included with your E-316 Series rower.

Reset Clears data

Program Clears current exercise program

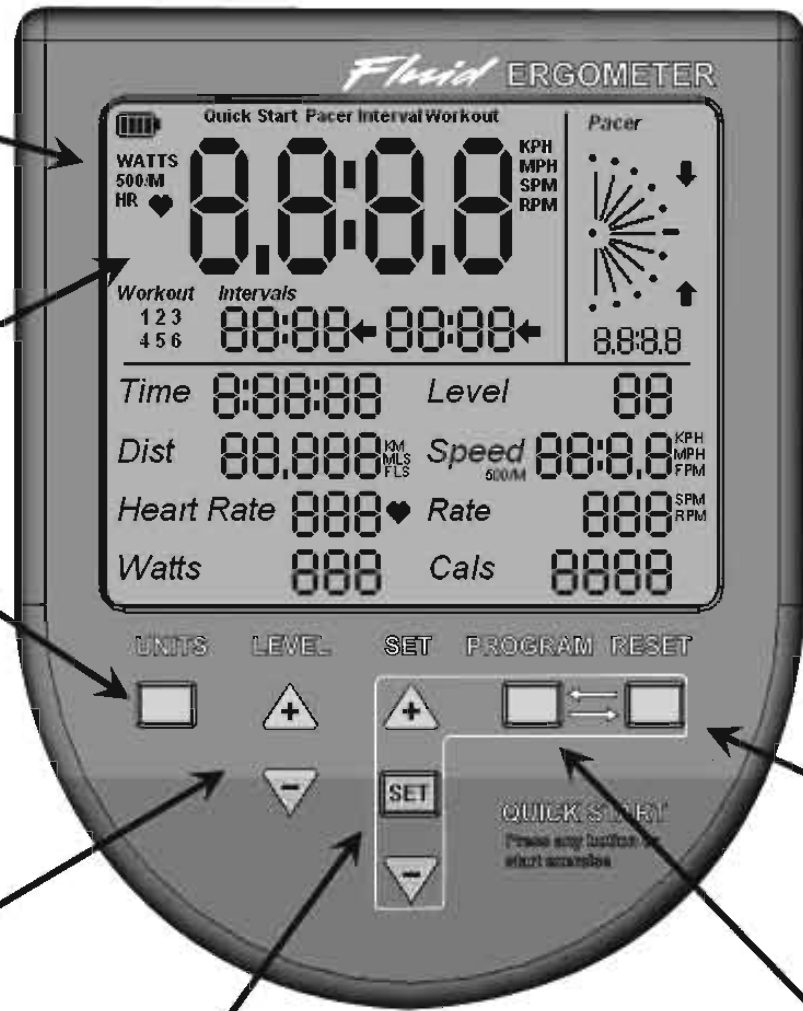

Replacing the E-316 bungee shock cord

Step 1 Remove the Perspex cover from rear of upper frame. Disconnect sensor lead.

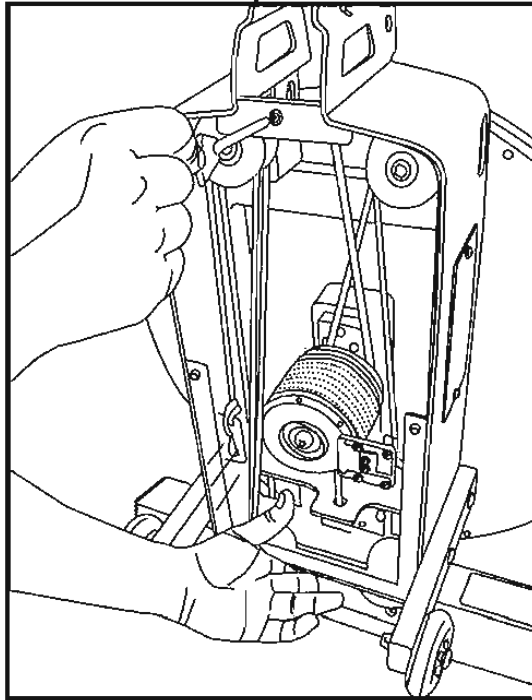

Step 2 Move the rowing handle from the S-bend handle catch to a point where it is resting on top of the tank. This helps line up the bungee cord hole for easier removal/replacement. Detach bungee cord from lower rear attachment point.

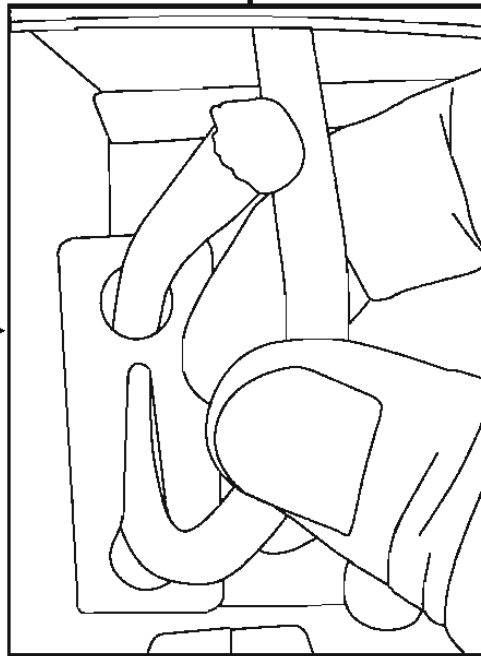

Step 3 Unwrap the bungee cord from all of the bungee pulleys.

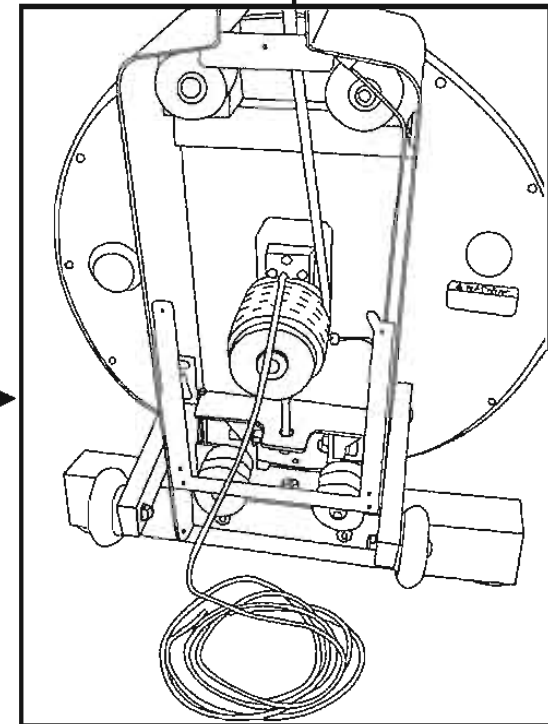

Replacing the E-316 bungee shock cord



Do not insert fingers into tank!

Step 4. Next, remove the magnetic ring. To loosen the rear mainshaft bolt holding the magnetic ring in place, it is necessary to keep the mainshaft and impeller assembly from turning with the bolt. Open the right rear tank plug, and insert a wrench wrapped in a lint free cloth (to protect the electroplating finish on the blades) to catch the impeller blade and allow the rear mainshaft bolt to be loosened as shown below right with a 6mm Allen key. **Caution:** Do not allow a dissimilar metal to directly contact the impeller blade. Premature rusting could occur. Cover any tool inserted the tanks with a lint free cloth and keep fingers clear.

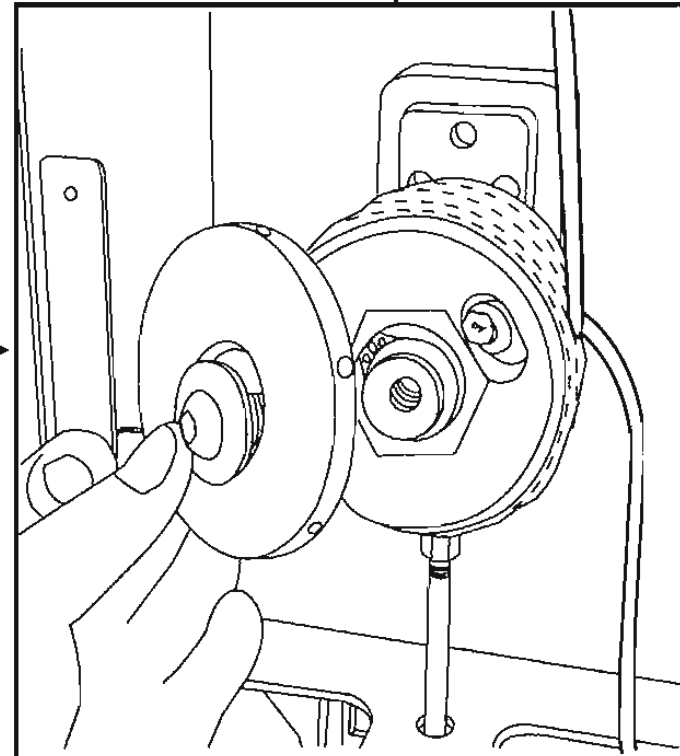
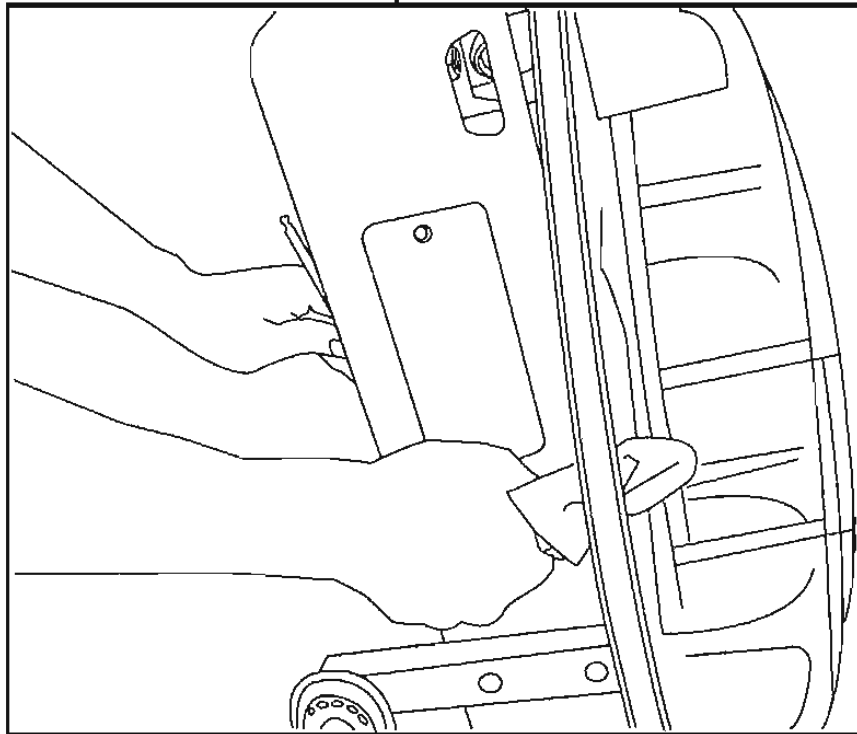

Replacing the E-316 bungee shock cord

Step 5. After removing the magnetic ring, the bungee cord will be accessible. Pull through the rope/bungee pulley and remove. Note that the rower handle should be resting on top of the tank (as shown in step 2) for the bungee hole to line up. Thread new bungee cord through and pull until knotted end is held securely in the slot.

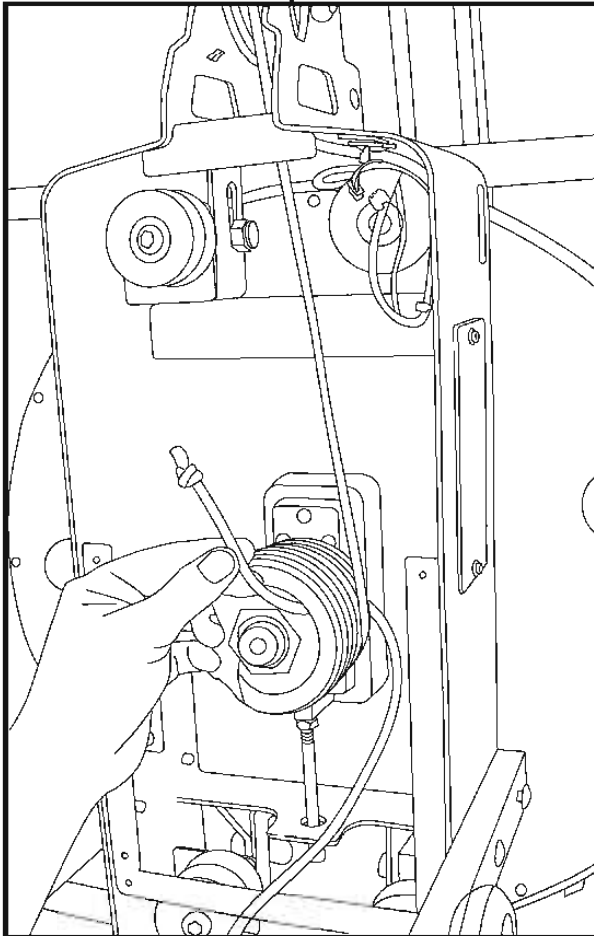

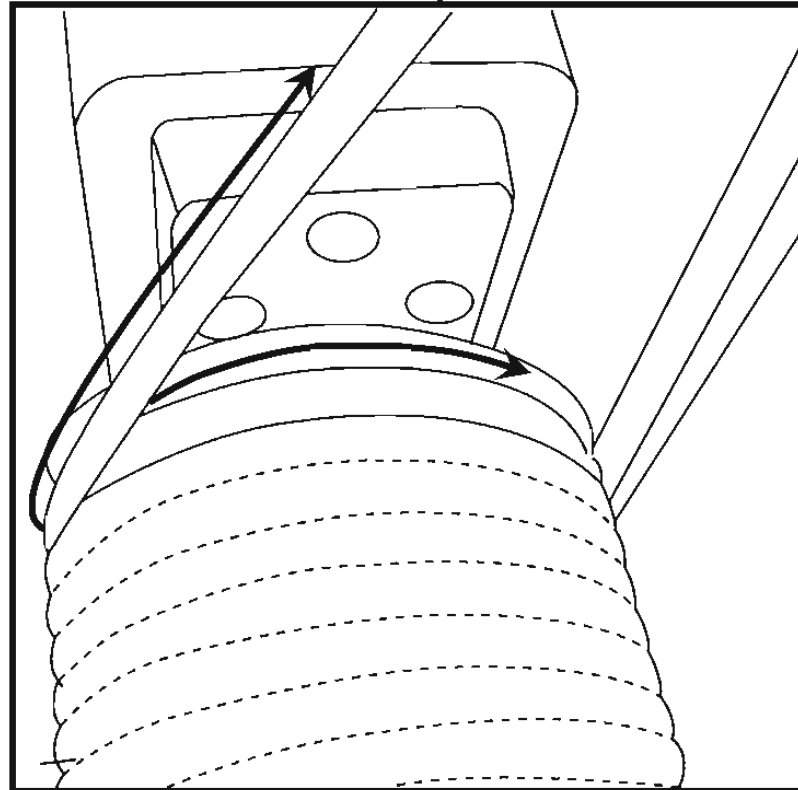

Step 6. Once the bungee cord is in position, make two wraps on the rope/bungee pulley in a clockwise direction, making sure the bungee cord tracks in the proper grooves. Make sure the bungee is wrapped behind the Dyneema rope. Once the bungee has reached the position shown below, you may begin to rewrap the bungee around the bungee pulleys, starting with the upper-right rear pulley.

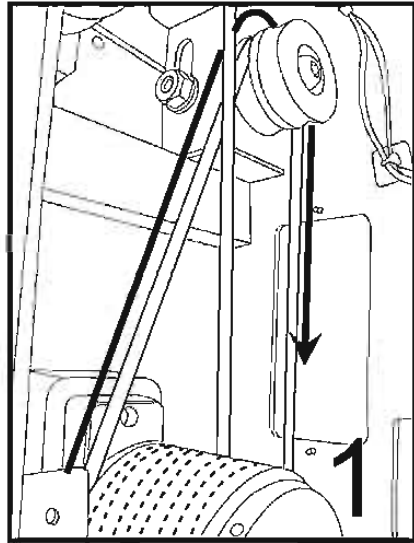
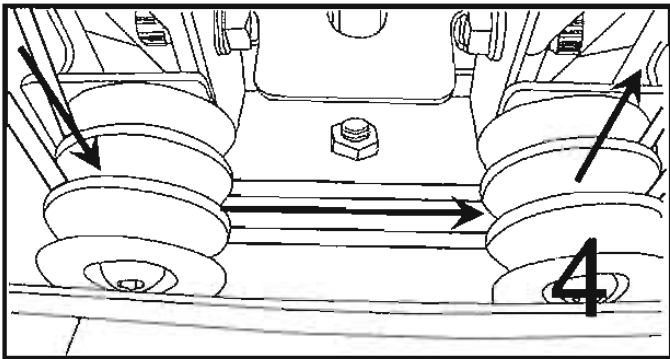
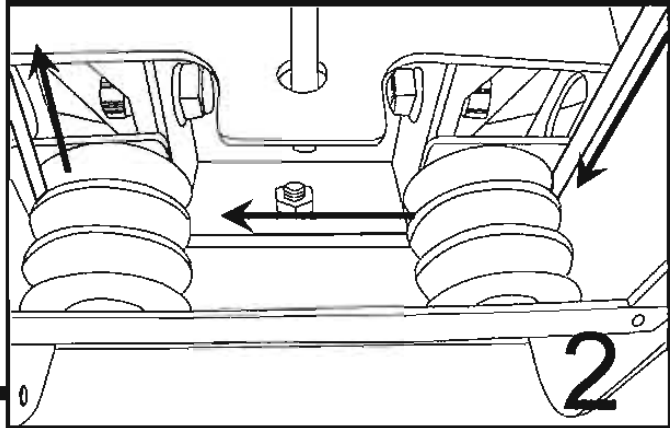
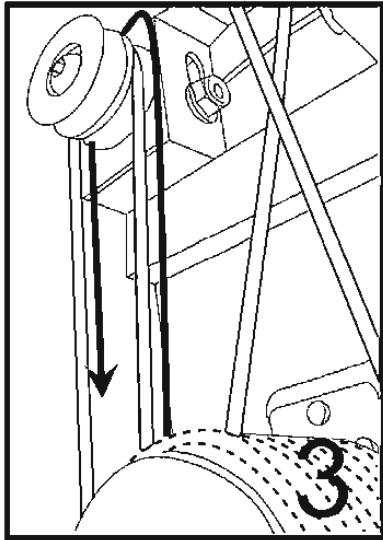

Replacing the E-316 bungee shock cord

- Bungee wrapping in order:**
1. Rope/bungee pulley to upper rear right bungee pulley.
 2. Upper rear right to lower rear right and left rear pulleys.
 3. Lower left rear to upper left rear pulley.
 4. Upper rear left to lower middle left and right pulleys.
 5. Middle right pulley to upper right front pulley.
 6. Upper front right pulley to lower front right and left pulleys.
 7. Lower left front pulley to upper left front pulley.
 8. Upper left front pulley to tie off point.



 Hint: Keep a slight tension on the bungee cord when threading through the bungee pulleys.

Replacing the E-316 bungee shock cord

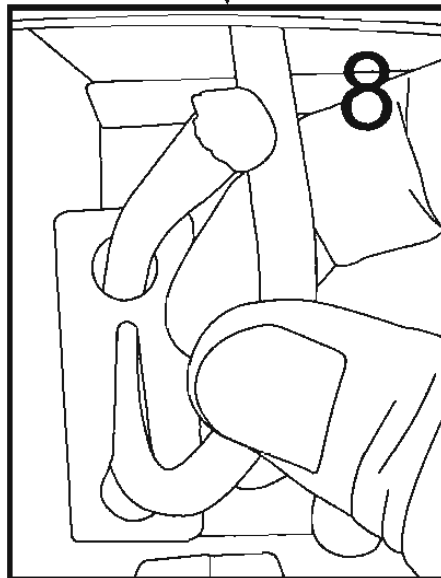
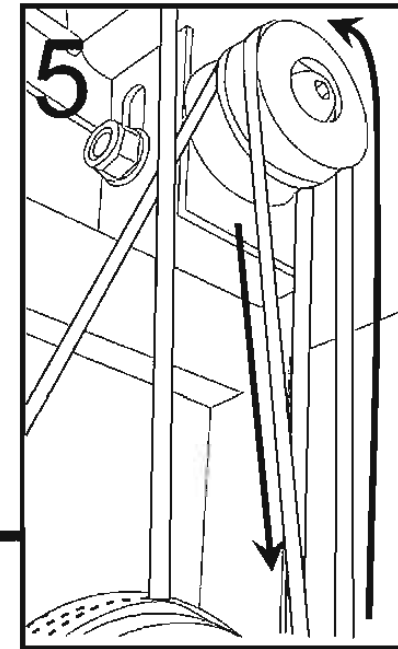
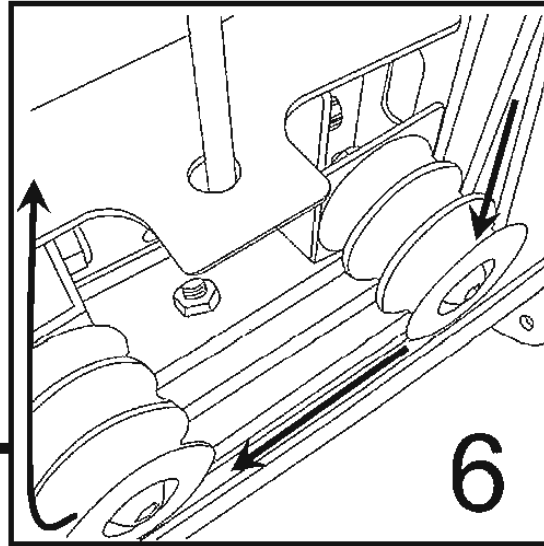
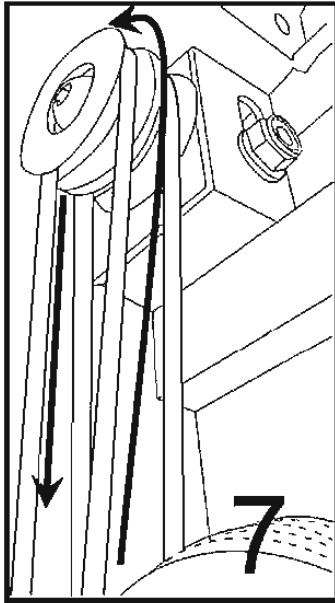

Reattach the magnetic ring.
Tighten securely.

Finally, reattach the sensor lead
and replace the Perspex rear
cover.

Finish the bungee rewrap by tying off the
bungee. You may elect to not use a tie wrap
as the metal tab is designed as a stand alone
attachment point. Thread the bungee
through to desired tension and thread the
bungee end through the upper hole as shown.

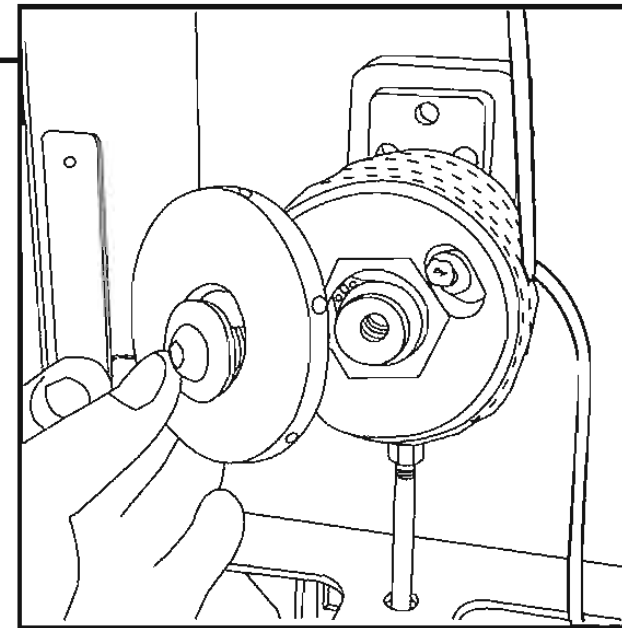

E-316 Parts list:

Item	Part #	Description	Qty
1	80200	Lower Frame	1
2	80700	Foot Plate	1
3	80400	Frame Tensioning Bolt Assembly	1
4	80800	Seat Rail / Rear Leg Assembly	1
5	10600	Seat Assembly	1
6	73600	S-bend Assembly	1
7	71016	Lower Frame Foot Leveler	3
8	10082	Washer M10	11
9	60121	Bolt (M10x90)	3
10	60806	Bolt (M10x180)	1
11	10041	Nut M10 Nylock	2
12	20008	End Cap 75x75	2
13	10140	10x47.5mm Rear Leg Bolt (takes 6mm insert bolt)	4
14	10081	Washer M6	6
15	10080	Bolt M6x20 for Seat	4
16	10121	Foot Plate Non Slip 3M each	2
17	10175	Protection Foam (inside rowing handle)	1
18	10176	Foot Strap	2
19	10177	Foot Strap buckle	2
20	10120	Screw M6x15	2
21	10174	Nut M6	2
22	60149	Spring Washer (M10)	3
23	10115	Bolt M10x80	1
24	71031	Hand Warning Decal	1
25	81004	E316 HOW TO ROW Decal	1
26	81005	Safety Strap	1
27	10099	Caution Decal	1
28	71036	M8 nut (Note: For tank tensioning bolt)	1
29	60130	Frame Rubber Bumper	3
30	83002	Complete Upper Frame Assembly	1
31	73004	M10x3x32 Washer	2
32	20150	Bolt M10x15	2
33	73700	Rope Pulley and Handle Assembly	1
35	73910	Sensor	1
36	73019	PVC Cover	1
37	10170	Washer M4	3
38	10070	Screw M4x10	3
39	11101	Heel Support	1

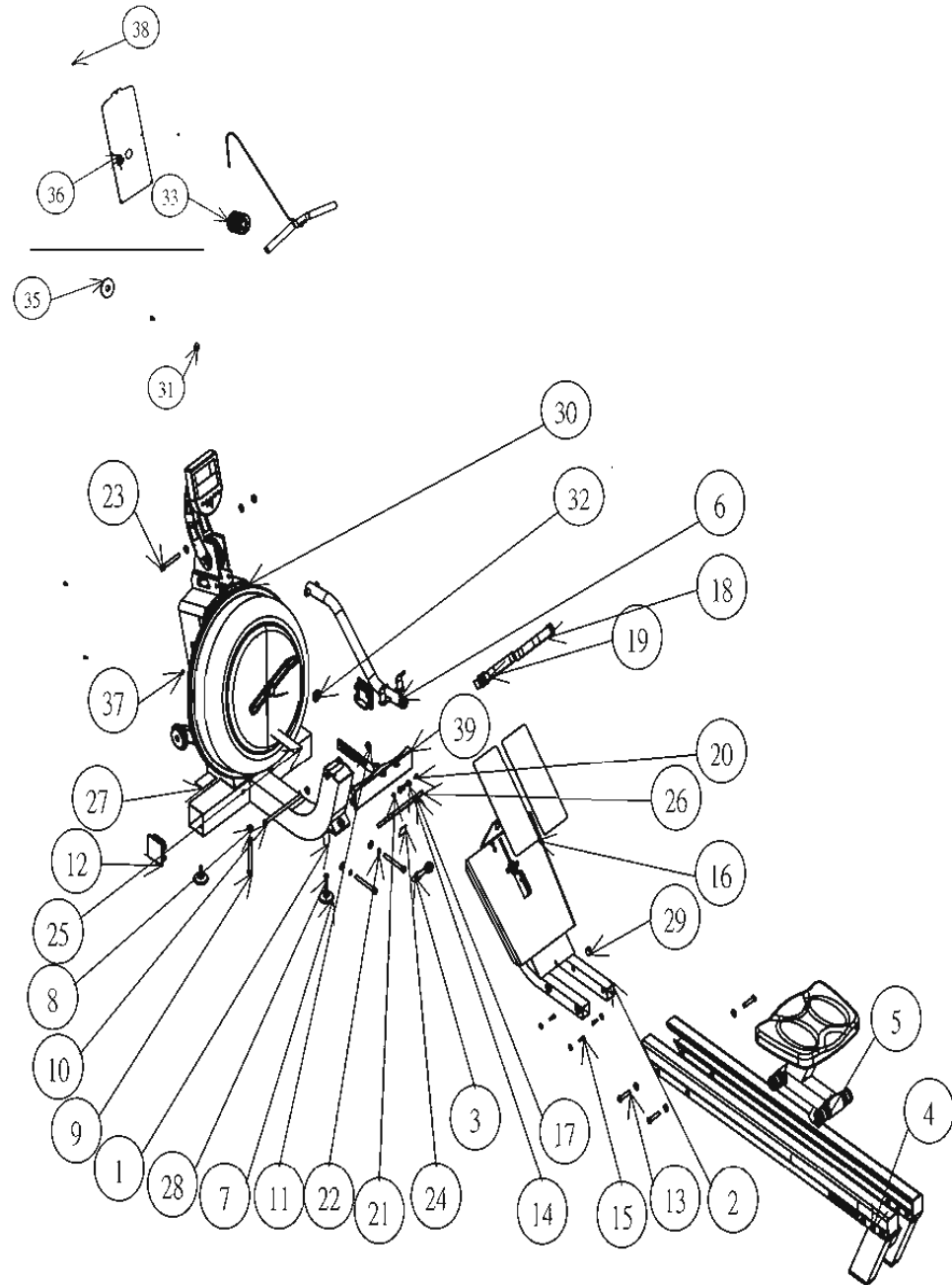

E-316 Exploded Upper Frame and Tank:

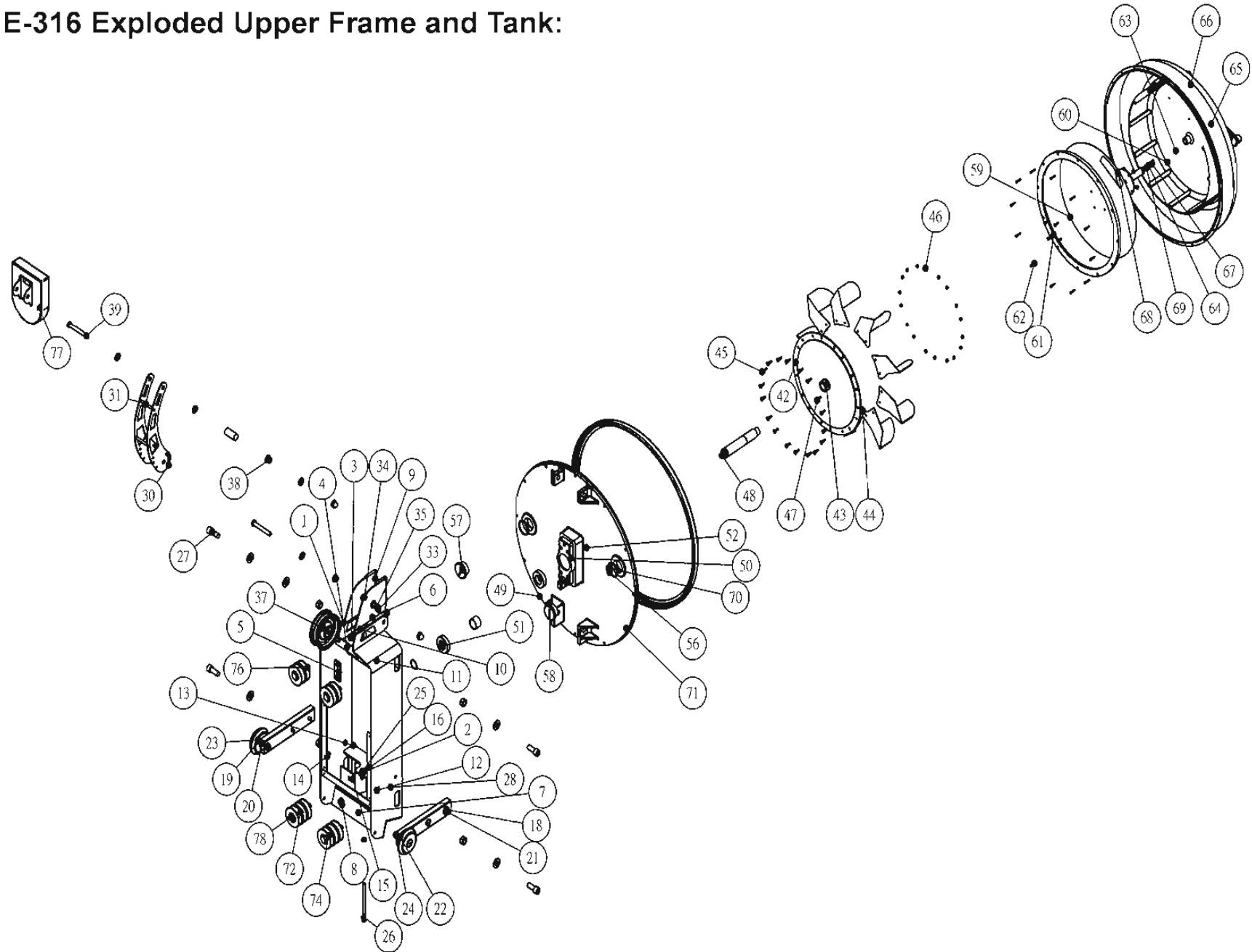

Parts list:

Item	Part Number	Description	QTY	Item	Part Number	Description	QTY
1	73102	Upper Main Frame Left	1	38	10082	Washer M10	6
2	73104	Upper Tank Mounting Bracket	2	39	10096	Bolt M10x70 for Aluminum Rail	2
3	73105L	Lower Left Tank Mounting Bracket	1	42	70311	Flywheel Plate	1
4	70111	Idle Wheel Bracket	1	43	70312	Flywheel Shaft	1
5	70113	Bungee Tie Off Bracket	1	44	10047	Impeller Blade	9
6	70114	Support Bracket	1	45	10033	Stainless Washer 10x4.2x1	22
7	70103	Upper to Lower Frame Mounting Bracket	1	46	10034	Stainless Nut M4	22
8	20029	Nylock Nut M10	3	47	10035	Stainless Bolt M4	22
9	70116	Rower Belt Guides	2	48	73313	Flywheel Shaft	1
10	73101	Upper Main Frame Right	1	49	10022	Aluminum Tank Back	1
11	73103	Frame Support Bracket	1	50	10185	Bearing Housing	1
12	70112	Bungee Pulley Mounting Bracket	4	51	10012	NSK 6005ZZ Bearing	2
13	73106	Tank Tensioning Bolt Bracket	1	52	10025	Seal NBR 37x30x8t for Flywheel Shaft	1
14	71036	M8 Nut (Note: For Tank Tensioning Bolt)	5	56	10039	Tank Plug O Ring 32x3.5	2
15	73104	M12 Nut	4	58	10046	Tank Large Seal	1
16	70110	Lower Perspex Mounting Bracket	3	59	10028	Stainless 0.8mm Backing Plate	1
18	73201	Transport Wheel Bracket	2	60	10045	PC Tank Cover	1
19	73200	Transport Wheel Assembly	2	61	10030	Blue Adjuster PP Tank Ring 358x10	1
20	73100	Main Frame Assembly	4	62	10036	Screw M3x20 SS for Blue Tank Ring	12
21	73001	M8x35 Bolt	4	63	70320	Blue Tank Ring Holding Screw Stainless Steel M3x20	1
22	60708	Washer (M8)	8	64	10162	Grub Screw M8x10	2
23	63808	M8x60 Bolt	2	65	10184	Adjuster Handle (includes PU yellow cover #10193)	1
24	60709	Nut Nylock (M8)	2	66	10193	PU Yellow Adjuster Handle Cover	1
25	10190	Washer M8	1	67	10163	Stainless shaft	1
26	71018	Tank Bolt Adjuster Washer	1	68	10164	Adjuster Handle Shaft Base	1
27	10063	Bolt M12x30	4	69	10032	Nylon Resistance Adjuster O ring 12x9x1.5	2
28	10043	Washer M12	8	70	10044	Tank Black Outer Cover Ring	1
30	73501	Computer Stalk	2	71	10062	Bolt M3x12	12
31	70502	Computer Mounting Bracket	2	72	10084	Bungee Pulley	10
33	60606	Plastic Spacer M4	2	74	10085	Bearing NBN 6201zz	10
34	10170	Washer M4	2	76	73003	M12x50mm Bolt	2
35	71017	M4x15 Bolt	2	77	80903	Rowing Computer	1
37	60112	Belt Pulley Bearing 6000ZZ	2	78	73008	M12x70 Bolt	2

FLUID ROWER (model FR-E316)
INTERNATIONAL WARRANTY – COMMERCIAL USE

First Degree Fitness Limited warrants that the Fluid Rower (model E316), purchased from an authorized agent, is free from defects in materials and workmanship. First Degree Fitness or its agents will, at their discretion, repair or replace parts that become defective within the warranty period.

Metal Frame – 10 Year Limited Warranty

First Degree Fitness will repair or replace the metal Main Frame of the Rower should it fail due to any defect in materials or workmanship within 10 years of the original purchase. Warranty does not apply to frame coating.

Polycarbonate Tank & Seals – 3 Year Limited Warranty

First Degree Fitness will repair or replace the polycarbonate tank or seals should they fail due to any defect in materials or workmanship within 3 years of the original purchase.

Mechanical Components (of a non-wearing nature) – 2 Year Limited Warranty

First Degree Fitness will repair or replace any mechanical component should it fail due to any defect in materials or workmanship within 2 years of the original purchase.

Wearing Components – 2 Year Limited Warranty

First Degree Fitness will repair or replace any component should it fail due to any defect in materials or workmanship within 2 years of the original purchase.

Specific Inclusions

- Bungee recoil cord, belt and pulley
- Hand grips & foot straps
- Dyneema Rowing Cord
- Seat
- Seat rollers & bearings
- All rubber components
- Computer & speed sensor (excluding replaceable batteries)
- All drive belts & bearings
- Aluminum seat rails

General Exclusions

- Damage to the finish of any part of the machine
- Damage due to neglect, abuse or incorrect use of the machine
- Any charges for freight or customs clearance associated with the return or dispatch of parts
- Any damage to or loss of goods during transport of any kind
- Any labour cost associated with a warranty claim

General Conditions

- The serial number of the machine must be correctly registered with First Degree Fitness Limited or one of its appointed distributors
- First Degree Fitness Limited reserve the right to examine any part where replacement is claimed under warranty
- Warranty period applies only to the original purchaser from the date of purchase and is not transferable
- The product must be returned to your place of purchase in original packaging with transportation, insurance and associated charges paid for by you and risk of loss or damage assumed by you.

First Degree Fitness makes no other warranties except as stated here and expressly disclaims all warranties not stated in this warranty. Neither First Degree Fitness nor its associates shall be responsible for incidental or consequential damages