



X-STRINGER

X-ES STRINGING MACHINE



OWNER'S MANUAL

Issue 1 - May 2004



X-STRINGER

OWNER'S MANUAL

GAMMA X-ES

TABLE OF CONTENTS

PAGE 1 WARRANTY

PAGE 2 FEATURES

PAGE 3 ASSEMBLY INSTRUCTIONS

PAGE 5 POWER CONNECTION & CONTROLS

PAGE 6 MOUNTING THE FRAME

PAGE 8 STRINGING THE FRAME

PAGE 11 ADDITIONAL FEATURES

PAGE 12 PATHFINDER AWL

PAGE 13 MAINTENANCE AND ADJUSTMENTS

PAGE 15 TROUBLESHOOTING TIPS

PAGE 17 PARTS LIST

PAGE 18 PARTS DRAWING

LIMITED WARRANTY

GAMMA Sports (GAMMA) warrants to the original purchaser that the X-STRINGER stringing machine ("EQUIPMENT") purchased is free from defects in materials and workmanship for a period of five (5) years from the date of original purchase for mechanical parts (excluding electrical parts and string clamps), and for a period of one (1) year from the date of purchase for all electrical parts and string clamps. Should any defects develop under normal use within the specified time periods, GAMMA will at its option, repair or replace the defective EQUIPMENT provided it is returned to GAMMA prepaid at the purchaser's expense. This warranty does not apply to any damage or defect caused by negligence, abuse, misuse, unauthorized alteration, shipping, handling, or part wear and tear as a result of normal use.

Routine maintenance, adjustment, and cleaning required to ensure proper operation are the responsibility of the purchaser and are not covered under the terms of this warranty. These include, but are not limited to: String Clamp adjustment, as described on page 11, Quick Action Clamp Base adjustment, as described on page 11, and the cleaning procedures listed on page 13.

GAMMA's obligation under this warranty is limited to repair or replacement of defective EQUIPMENT, and no one is authorized to promise any other liability. GAMMA shall in no event be liable for any incidental or consequential damages.

To return defective EQUIPMENT, a return authorization (RA#) must be obtained from a GAMMA customer service representative. The RA# must be marked on the outside of the shipping carton being returned. All returns must be shipped prepaid by the customer to GAMMA. Please retain the original shipping carton and packing materials for any future shipments. GAMMA will not be responsible for machines which are not sent in the original undamaged packaging.

GAMMA X-ES

MACHINE FEATURES



MACHINE FEATURES

- ❖ Electric Constant Pull Tensioner w/ 11 lb. to 89 lb. Tension Range
- ❖ Digital Tension Setting Display
- ❖ Professional Six Point “Quick Mount” Racquet Mounting System - Accomodates All Racquets Without Adapters
- ❖ Parallel Jaw Rotating Gripper w/ Diamond Dust Coated Gripping Surfaces
- ❖ Professional Dual Action, Rotating, Diamond Dust Coated, Fixed String Clamps
- ❖ High Strength Extruded Aluminum Frame with Durable Anodized Finish and Convenient Padded Tool Tray
- ❖ Unique Internal Drawer System for Storing Tools and Adaptors.
- ❖ Convenient Foot Actuated Tensioner Switch

ASSEMBLY INSTRUCTIONS

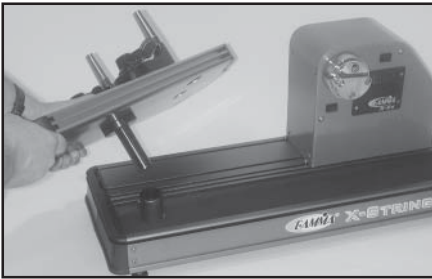

Turntable Installation

Insert the turntable pin into the bushing of the machine base.



Support Post Installation

To install the support posts you must first remove the mounting bolt from the mounting plate that sets inside the central cavity of the turntable. There are large holes stamped on the underside of the turntable that allow you to support the mounting plate with your fingers while removing the mounting bolt.

Remove and Discard Plastic Washers

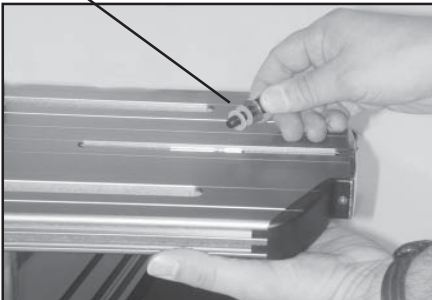

Support Post Installation (con't)

After removing the mounting bolt, remove and discard the plastic washers that are installed for shipping purposes.

ASSEMBLY INSTRUCTIONS

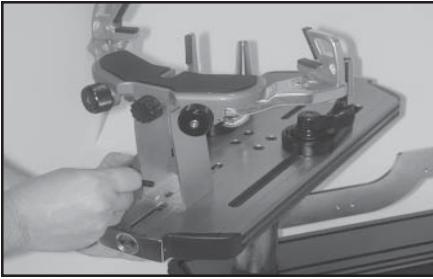

Support Post Installation (cont'd)

Place the support post onto the central slot of the turntable. With your fingers placed through the large hole in the underside of the turntable, press the mounting plate against the inside top surface of the turntable while aligning the hole in the support post with the hole in the mounting plate and fix them with the mounting bolt. Repeat procedure on to attach the support post on the opposite side of the turntable.

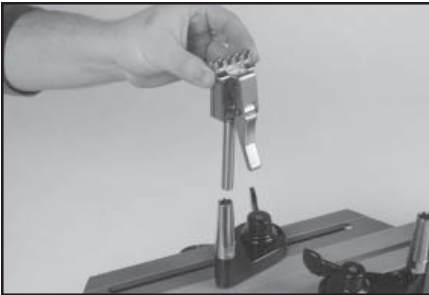

String Clamp Installation

The post of the string clamp and tube of the string clamp base are treated with grease to provide protection against corrosion during shipping. Remove any excessive grease with a clean cloth prior to use. The post and tube may also be cleaned with isopropyl alcohol. After this type of thorough cleaning, the post and tube should be treated with a light coating of machine oil to protect the surfaces against corrosion and to ensure smooth operation.

POWER CONNECTION & CONTROLS

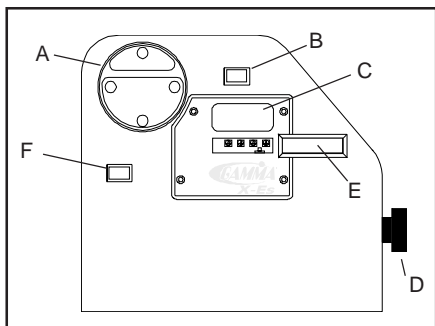

Front Panel Features

- A - String Gripper
- B - Tension Switch
- C - L.E.D. Tension Display
- D - Tension Adjustment Knob
- E - Calibration Screw Cover Plate
- F - Gripper Reversing Switch

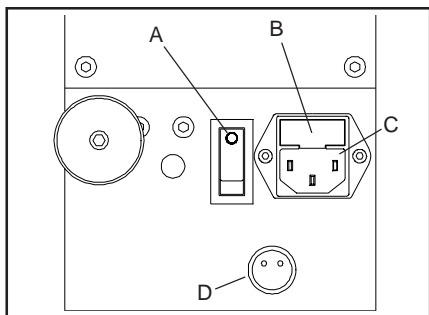

Side Panel Features

- A - Lighted Power Switch
To turn the power on, press the left side of the switch.
- B - 5 Amp Fuse Holder (w/ spare fuse)
- C - A/C Power Cord Socket
- D - 2 Pin Foot Pedal Switch Receptacle

Instructions for Power Connection and Controls

CAUTION ! Before connecting to the power supply, check the voltage supply switch located on the back side of the tensioner. To change from 110 to 220 volt service slide the switch fully to the left or to the right until “115V” or “230V” appears on the switch plate.

The acceptable range of input voltages for the “115 V” setting is between 110 V and 120 V @ 60 Hz and for the “230 V” setting, between 220 V and 240 V @ 50 to 60 Hz. If you have any question regarding the input voltage supply for your area, please ask your electric utility company. When using extension cords, use grounded heavy duty extension cords rated for 15 AMP service.

To install the power cord, insert the female end of the power cord into the Power Cord Socket located on the rear panel (letter C). To connect the foot pedal switch, insert the 2 pin male connector located at the end of the foot pedal switch cord into the two pin receptacle located on the back panel. Tighten the connector with the sleeve nut located on the foot pedal switch connector.

After checking to be certain that the machine is set for the correct input voltage, switch on the machine by pressing the Lighted On-Off Power Switch on the rear panel.

WARNING! FOR INDOOR USE ONLY. TO BE USED BY ADULTS OR UNDER ADULT SUPERVISION ONLY. NEVER OPEN UNIT WITH POWER CONNECTED

POWER CONNECTION & CONTROLS



Setting Tension

The stringing machine utilizes an adjustment knob along with a digital L.E.D. display to indicate the tension setting. To set the tension, rotate the adjustment knob clockwise to decrease the displayed tension and counter-clockwise to increase the displayed tension, until the desired tension is displayed. Aramid fiber and metallic strings will generally string up tighter on the X-ES machine compared to synthetic or natural gut strings. Therefore, when stringing

with Aramid (Kevlar, Technora) hybrid strings or metallic strings, we recommend setting tension 4-5 lbs. lower than you would normally use for synthetic or natural gut strings.

MOUNTING THE FRAME

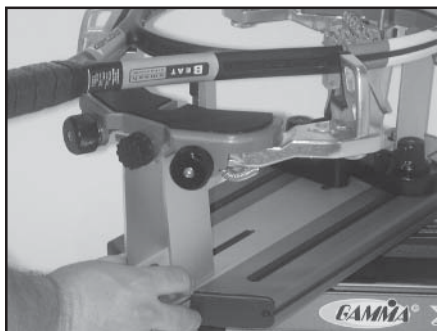

Adjusting the Frame Support Posts

Loosen the lock bolts of the frame support posts and space them apart with the frame support slides separated by the approximate length of the racquet head. Although it is not required, it is good practice to center the support posts on the turntable. Lock one of the posts in position by tightening the lock bolt and position the other post until the frame support slide is positioned near the inside surface of the racquet frame. Securely tighten the lock bolt of the second support post.

Caution: To avoid racquet damage, the center posts should not contact the racquet prior to locking down the support posts.



Tightening the Frame Supports

Tighten the Frame Support Slides by turning the adjustment knob clockwise until snug against the racquet frame and slight resistance is felt.

Caution: Overtightening the Center Supports will stretch the head of the racquet and could cause racquet damage.

MOUNTING THE FRAME

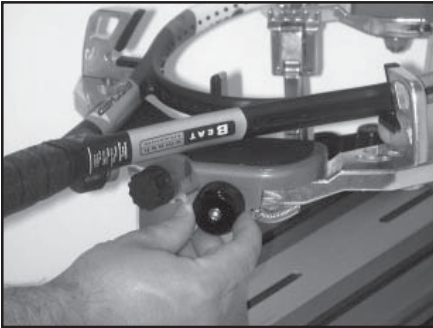

Frame Shoulder Support Adjustment

Being sure the shoulder supports are free to swivel in their mountings, simultaneously rotate the shoulder support adjustment knobs clockwise until both shoulder supports gently and squarely contact the frame.



Securing the Frame Shoulder Clamps

Lock the shoulder supports in position by turning the knob at the base clockwise.

Repeat the adjustment procedure for the remaining support post.

Re-tighten all of the frame supports in the same order as before.

Do not overtighten any of the supports as racquet damage may occur.

The supports should be tightened to the point where the racquet frame will not move in the mounting system when the handle is grasped and attempts are made to move it. Should any supports lose contact with the frame while stringing, they should be re-tightened.

STRINGING THE FRAME

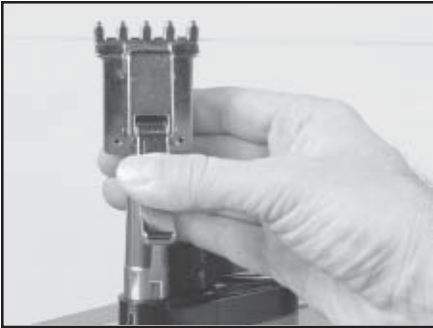

String Clamp Operation

The string clamps are a dual action design where the string clamp and clamp base operate independently of one another.

To clamp a string, lift the clamp head and place the string between the jaws and depress the string clamp lever to secure the string. The clamping pressure applied to the string should be adjusted to provide sufficient pressure to secure the string when subjected to the desired pulling tension. The diamond coated gripper plates provide for increased friction between the clamps and

the string to allow for reduced clamping pressure while securing and holding the string under tension.

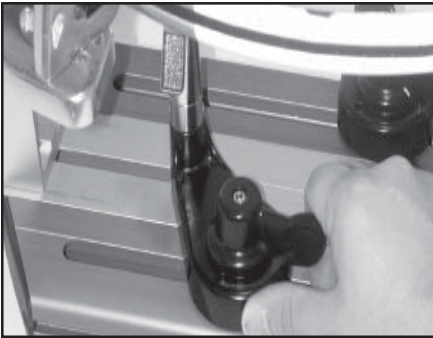

Clamp Base Operation

To lock the string clamp base to the turntable, rotate the clamp base locking lever clockwise. To release the string clamp base from the turntable, rotate the clamp base locking lever counter-clockwise.

The Locking Lever should be tightened enough to prevent clamp base slippage on the turntable, when the desired tension is placed on the string. To go from the loose position to the clamped position and back, generally requires the rotation permitted by the slot in the clamp base.

STRINGING THE FRAME

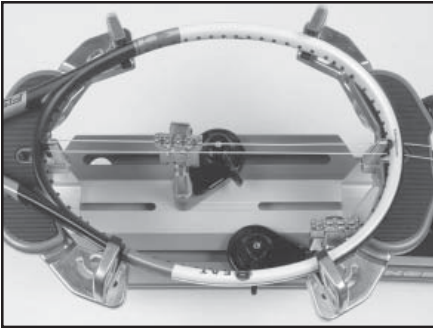

Getting Started

To begin stringing the main strings, thread the two ends of the string through the two center holes at the appropriate end of the frame and continue through the opposite center holes. Thread one end of the string through the adjacent grommet hole and pull excess by hand.

Secure one of the strings using a string clamp.

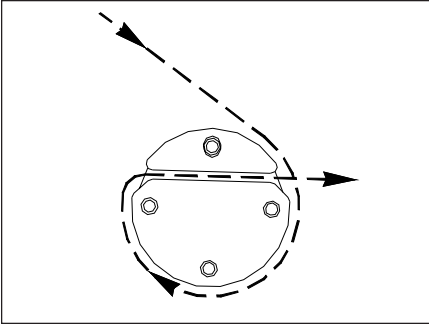

Pulling Tension

To pull tension, wrap the free string clockwise around the gripper drum and position the string between the gripper jaws.

The string must pass over the top half of the gripper before being placed between the gripper jaws, as the tension on the string provides the clamping force to the gripper jaws.

Gently pull the string until all slack is removed.

WARNING: KEEP FINGERS AWAY FROM GRIPPER DRUM WHILE TENSIONING STRING. PUSH GRIPPER REVERSING SWITCH IN CASE OF EMERGENCY.

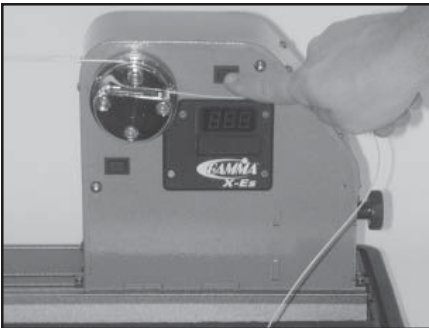

To tension a string, push the tension switch or the foot pedal. The string gripper will rotate and slowly apply tension to the string. When the set tension has been attained, the gripper will stop rotating. As the tensioned string stretches, the gripper may rotate intermittently, maintaining the set tension.

To release the string after clamping, push the tension switch or foot pedal. If the string gripper does not release the string, depress and hold the Gripper Reversing Switch once to release the string.

STRINGING THE FRAME

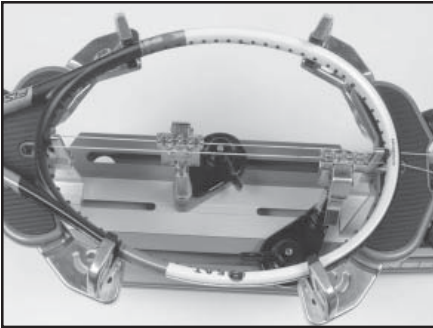

Clamping the First Main String

Secure the tensioned main string using the remaining fixed clamp. Repeat the procedure for all of the remaining main strings and tie off following the racquet manufacturers recommendations.

Follow the manufacturer's recommended stringing pattern for one or two piece stringing. This will determine the starting point for the cross strings. If applicable, tie the first cross string using an appropriate starting knot.



Weaving the Cross Strings

Weave the cross strings over and under the main strings being careful to alternate the weave direction of each consecutive cross string so as to be opposite of the previously installed cross string.

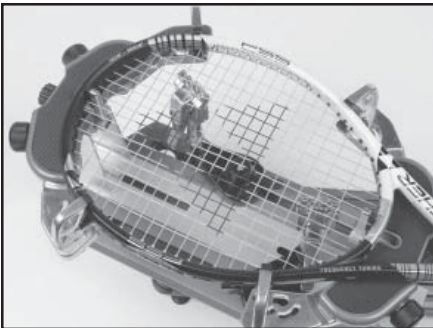

Completing the String Job

Once the final cross string is tensioned and clamped, tie off at the appropriate hole specified by the racquet manufacturer. Remove the frame from the mounting system by loosening the shoulder supports and frame supports.

ADDITIONAL FEATURES

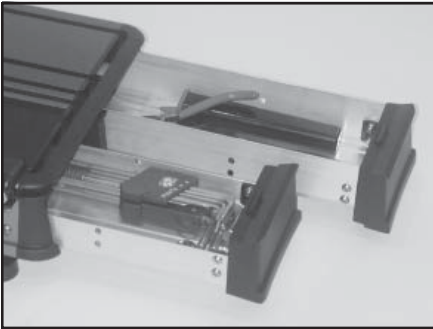

Storage Drawers

There are two storage drawers located in the base of the machine. The drawers open from the right end of the base and lock into the end cap with a spring loaded latch.

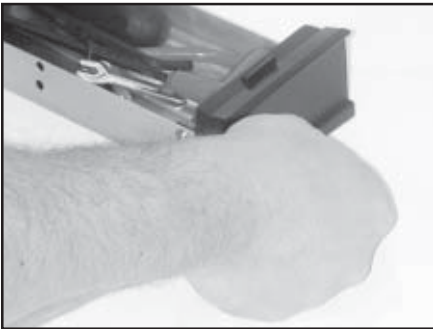

To open the drawers, reach under the right side end caps to find the the spring loaded latch handle. Pull the latch handle toward the outside of the end cap to release latch from the end cap and slide the drawer out.

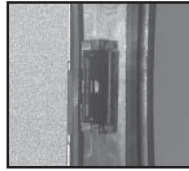

To close the drawer simply slide the drawer back inside the base and the latch with automatically lock into place.

View from underside of end cap showing latch handle.



Cutting Block

A cutting block is provided to provide a surface for cutting a point on the strings using a razor blade cutter.

PATHFINDER AWL

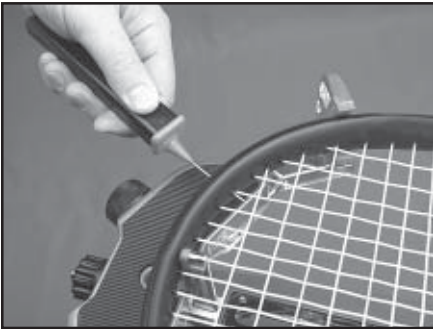

The X-ES includes the Pathfinder stringing awl which creates a pathway between or around strings to make inserting a string through tight grommets easier and quicker.

Insert the awl through the grommet hole in the same manner as for traditional awls. The Pathfinder awl must be in the closed position before insertion.

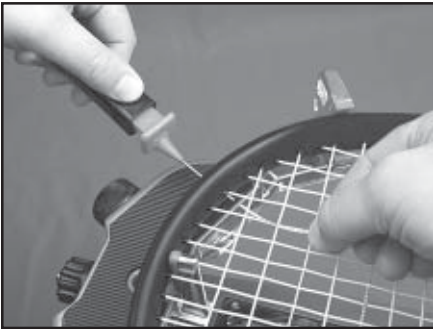

Once the awl is inserted, pull the handle of the awl outward while holding the tip section in place, leaving the outer sheath in the grommet hole.

Insert the end of the string into the center of the sheath.



While holding pressure on the string, slowly pull the sheath out of the grommet hole to leave the end of the string exposed.

MAINTENANCE and ADJUSTMENTS

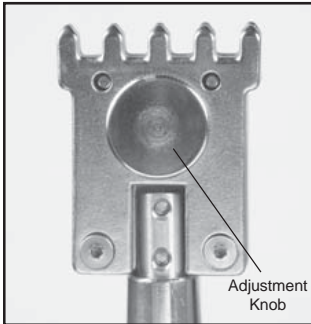

Adjusting the String Clamp Jaw Spacing

The string clamps will need minor adjustments according to what string type, construction, and gauge you are using.

To adjust the gap (clamping pressure) between the clamp jaws, insert the string through the racquet as if you were beginning the main strings. Clamp the strings and pull tension. If the string slips through the jaws of the clamp, tighten the clamp by compressing the clamp jaws together by hand while turning the Adjustment Knob, in the clockwise direction. If the clamp leaves impressions or damages the string, it may be excessively tight and should be adjusted by turning the Adjustment Knob

counter clockwise to open the gap between the jaws. The clamp jaws should be cleaned periodically to be free from dirt, oil, and any string coating for them to grip properly. Knife sharpening stones are excellent for removing build-up on the diamond coated surfaces and are available.

Note: The string clamps supplied with your stringing machine can accommodate tight string patterns such as badminton. Depending on the string pattern, the clamp may spread the strings slightly which will not compromise the quality of the string job. String clamps designed specifically for badminton racquets are available.



Closed Position



Open Position

String Clamp Base Adjustment

The string clamp bases do not require adjustment. The simple “Lever Bolt & Nut” design, provides maximum flexibility for providing clamping pressure to the turntable and running clearance for repositioning. Approximately 1/2 turn is all that is needed to lock and release the clamp base from the turntable.

NOTE: Do not attempt to adjust the clamp base using the attachment nut on the underside of the clamp.



Turntable Bushing Adjustment

The turntable bushing is adjusted at the factory for optimum performance. After time and use, the turntable bushings may need minor adjustment. An adjustment is indicated when noticeable turntable looseness or wobble occurs while stringing.

To adjust the fit between the turntable pin and the bushings, tighten the set screw at the top of the bushing using a 3mm hex wrench. Tighten until the turntable rotates smoothly without excessive free play.

MAINTENANCE and ADJUSTMENTS

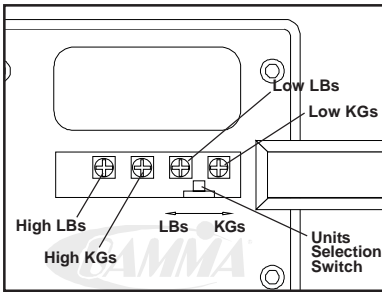

Tension Calibration Procedure

If you suspect that tensioner is not pulling the correct tension, you should check the tension with a Tension Calibrator which provides a measurement of the actual pulling tension being applied by the machine.

With the tension set at 20 lbs, place one end of a calibrator equipped with synthetic string into a string clamp. Place the opposite end into the string gripper and apply tension. If the measured tension is inaccurate, remove the rectangular cover from the L.E.D. display cover plate cover.

Rotate screw ("Low LBs") in small increments until the displayed tension matches the tension indicated on the calibrator. Set the machine tension to 80 lbs. and apply tension to the calibrator. If the measured tension is inaccurate, rotate screw ("High LBs") in small increments until the displayed tension matches the tension indicated on the calibrator. Since adjustment of the "Low LBs" screw at 20 lbs can influence the tension at 60 lbs and visa versa, repeat these steps until the set tension matches the tension reading of the calibrator at both 20 and 60 lbs. Replace the rectangular cover in the L.E.D. display cover plate.

To switch from Lbs to Kgs, slide the units selection switch to the left for "LBs" and to the right for "KGs".

Please note that there will be a range of tension from the maximum tension at which the tensioner stops pulling (high end of the range), to the minimum tension at which the tensioner starts pulling again (low end of the range). This difference between the high and low end of the range can vary from 2-4 lbs depending on the string used to calibrate the machine and the speed of the tensioner. For consistency, we recommend that the tension setting of the machine be calibrated as close as possible to the high end of the range, which is the method used at the factory. Using this method will be the most consistent and will also insure that the raquet will not be over tensioned.

TROUBLESHOOTING TIPS

PROBLEM

SOLUTION

String slips in clamps.

- Adjust gap between jaws.
- Clean clamp jaws.

String slips in gripper.

- Clean gripper jaws.
- Make sure string is wrapped over top jaw of gripper prior to inserting between gripper jaws.

String clamp base slips on turntable.

- Adjust Clamp Base Locking Nut.

Electrical system does not function.

- Check power source.
- Check power cord connection.
- Check stringing machine fuse.
- Check for proper voltage setting (110/220) of machine.
- Call customer service.

String tension too tight or too loose.

- Check tension using a tension calibrator and adjust machine calibration if necessary

FUSE REPLACEMENT

To change the fuse, remove the power cord and pull the fuse holder straight out. Remove the old fuse from the holder and replace it with the supplied spare. Replace the fuse holder into the machine and check for proper operation.

CARE and CLEANING

With time and use, the clamping surfaces of your machine may become oily or dirty and result in string or clamp slippage while stringing. Periodic cleaning of the following parts is recommended.

String Clamps

Clean the inside gripping surfaces of the string clamp jaws by inserting a cloth or pipe cleaner soaked with isopropyl alcohol between the jaws and rub back and forth. If the build-up is excessive, dismantle the string clamp jaws to expose the gripping surfaces by removing the adjustment screw. Using a small nylon brush, (such as a toothbrush), scrub the inside surfaces until all debris is removed. Clean the jaws with isopropyl alcohol and re-assemble.

String Clamp Base

Clean the base of the clamps and the top of the turntable with isopropyl alcohol.

String Gripper

Follow the same procedure for cleaning the string clamps.

NOTES

PARTS LIST

PART #	DESCRIPTION	PART #	DESCRIPTION
4A	TURNTABLE BUSHING	259	SLIDE BRACKET
5	RUBBER FEET	262	SUPP MOUNTING PLATE
6A	CAP SCREW - M8	263	SMALL DRAWER
8	BUSHING SET SCREW	265	SMALL DRAWER END CAP
9	WASHER - M8	269	BASE CLAMP
14	WASHER	270	FRAME SUPP SLIDE KNOB
21	FRAME SUPP SLIDE	271	SUPP POST MOUNTING PL
MFSP	BADMINTON ADAPTER	274	CHOP BLOCK
MFSP	TENNIS ADAPTER	275	LARGE DRAWER
MRS	DIE CAST GRIPPER JAWS	276	LARGE DRAWER END CAP
37	CAP SCREW	277	BASE CORNER CAP
101	A/C POWER CORD	278	BASE CORNER CAP
102	FUSE HOLDER	279	BASE
103	5A FUSE	280	TRAY PAD
MMS	SHOULDER PADS	281	TENSIONER
131	FOOT PEDAL SWITCH	282	TURNTABLE
140	MTNG. STAND TOP PLATE	283	END CAP
141	MTNG. STAND PAD	MDCSC10	STRING CLAMP
142	SUPPORT ARM - LEFT	285	TT END CAP - RIGHT
143	SUPPORT ARM - RIGHT	286	TT END CAP - LEFT
144	SUPPORT LOCK KNOB	287	BASE END CAP
145	ARM RETURN SPRING	288	BASE END CAP
146A	ARM ADJUSTMENT KNOB		
147	ARM ADJUSTMENT SCREW		
148	SHOULDER V-CLAMP		
244	GRIPPER DRUM		
			TOOLS AND ACCESSORIES
		70	HEX WRENCH - 5MM
		MPSA	PATHFINDER AWL
		MA	STRINGERS AWL
		98A	10MM WRENCH
		108	UTILITY KNIFE
		109	NEEDLE NOSE PLIERS
		167	10 PC. HEX WRENCH SET

PARTS DRAWING

