

in **STRIDE**[®] *Plus* **Electronic Stepper**
with Total Body Resistance Tubes

Owner's Manual

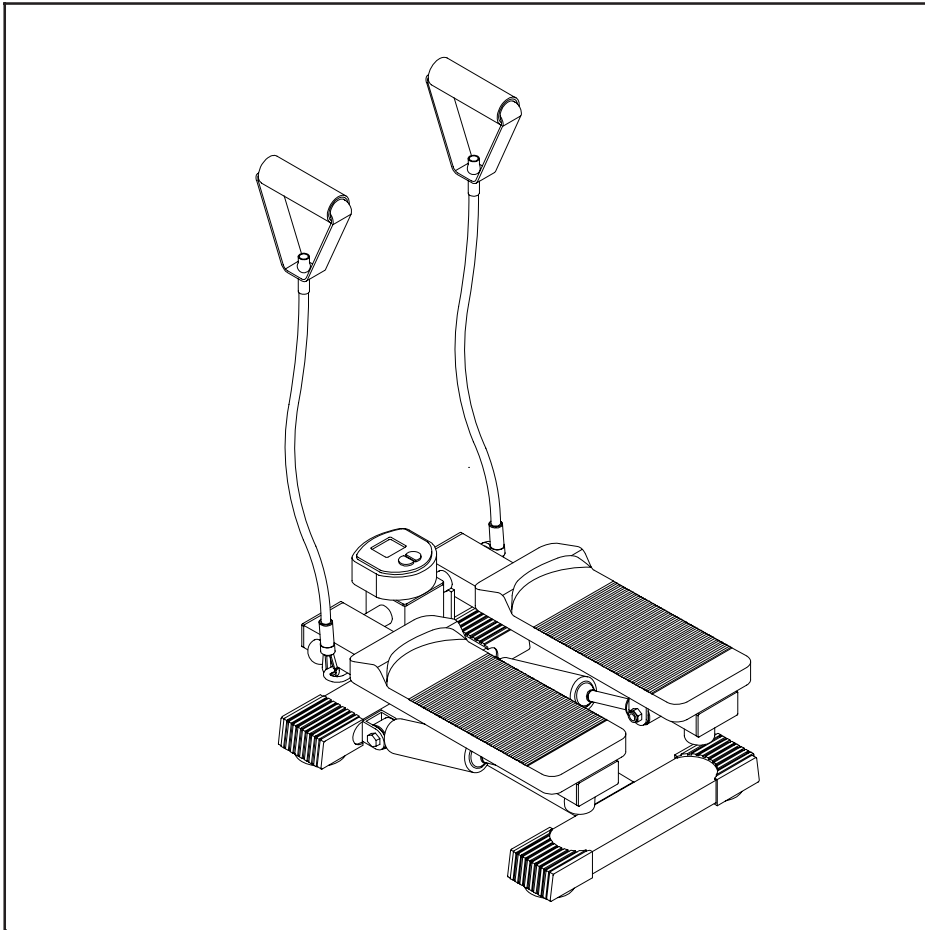

CAUTION:

Weight on this product should not exceed 250 lbs.

! WARNING !

Exercise can present a health risk. Consult a physician before beginning any exercise program with this equipment. If you feel faint or dizzy, immediately discontinue use of this equipment. Serious bodily injury can occur if this equipment is not assembled and used correctly. Serious bodily injury can also occur if all instructions are not followed. Keep others and pets away from equipment when in use. Always make sure all bolts and nuts are tightened prior to each use. Follow all safety instructions in this manual.

When calling for parts or service, please specify the following number.

40-0046

STAMINA PRODUCTS

MADE IN CHINA

Product May Vary Slightly
From Pictured.

This Product is Produced Exclusively by



2040 N. Alliance, Springfield, MO 65803

Customer Service Number

1 (800) 375-7520

www.staminaproducts.com

TABLE OF CONTENTS

	Page		Page
Safety Instructions	2	Conditioning Guidelines	8
Before You Begin	4	Warm-up and Cool-Down	9
Assembly Instructions	5	Product Parts Drawing	10
Set Up Instructions	6	Parts List	11
Storage	6	Warranty	12
Maintenance	6	Notes	13
Using The Electronic Meter	7	Fax/Mail Ordering Form	14

SAFETY INSTRUCTIONS

WARNING: To reduce the risk of serious injury, read the following Safety Instructions before using the **INSTRIDE PLUS**.

1. Read all warnings posted on the **INSTRIDE PLUS**.
2. Read this Owner's Manual and follow it carefully before using the **INSTRIDE PLUS**. Make sure that it is properly assembled and tightened before use.
3. Keep children away from the **INSTRIDE PLUS**. Do not allow children to use or play on the **INSTRIDE PLUS**. Keep children and pets away from the **INSTRIDE PLUS** when it is in use.
4. Inspect the resistance cords for nicks and cuts before each use. Do not use resistance cords that are nicked or cut.
5. It is recommended that you place this exercise equipment on an equipment mat.
6. Set up and operate the **INSTRIDE PLUS** on a solid level surface. Do not position the **INSTRIDE PLUS** on loose rugs or uneven surfaces.
7. Shocks on steppers get **HOT** during use. To avoid burns, do not touch the shocks until they have time to cool.
8. Always make sure that the Cable(9) is properly seated in the groove on the Pulley(8) before using the **INSTRIDE PLUS**.
9. Inspect the **INSTRIDE PLUS** for worn or loose components prior to use.
10. Tighten/replace any loose or worn components prior to using the **INSTRIDE PLUS**.
11. Consult a physician prior to commencing an exercise program. If, at any time during exercise, you feel faint, dizzy, or experience pain, stop and consult your physician.
12. Follow your physician's recommendations in developing your own personal fitness program.
13. Always choose the workout which best fits your physical strength and flexibility level. Know your limits and train within them. Always use common sense when exercising.
14. Do not wear loose or dangling clothing while using the **INSTRIDE PLUS**.
15. Never exercise in bare feet or socks; always wear correct footwear, such as running, walking, or crosstraining shoes. Be sure that they fit well, provide foot support and feature non-skid rubber soles.
16. Be careful to maintain your balance while using, mounting, dismounting, or assembling the **INSTRIDE PLUS**, loss of balance may result in a fall and serious bodily injury.
17. The **INSTRIDE PLUS** should not be used by persons weighing over 250 pounds.
18. The **INSTRIDE PLUS** should be used by only one person at a time.
19. The **INSTRIDE PLUS** is for consumer use only. It is not for use in public or semipublic facilities.

WARNING: Before starting any exercise or conditioning program you should consult with your personal physician to see if you require a complete physical exam. This is especially important if you are over the age of 35, have never exercised before, are pregnant, or suffer from any illness. **READ AND FOLLOW THE SAFETY PRECAUTIONS. FAILURE TO FOLLOW THESE INSTRUCTIONS CAN RESULT IN SERIOUS BODILY INJURY.**

CALL US FIRST



CUSTOMER SERVICE NUMBER
1 (800) 375-7520

**THANK YOU FOR PURCHASING THE
INSTRIDE PLUS**

To help you get started, we have pre-assembled most of your **INSTRIDE PLUS** at the factory with the exception of those few parts left unassembled for shipping purposes. Simply follow the few assembly instructions set forth in this manual. Within a few minutes you will be getting your body into shape and on your way to achieving a happier and healthier lifestyle.

Should you have any questions,
please call our Customer Service Department toll-free number,
1 (800) 375-7520
Monday - Friday, 8:00 A.M. - 5:00 P.M., Central Time.

BEFORE YOU BEGIN

Thank you for choosing the **INSTRIDE PLUS**. We take great pride in producing this quality product and hope it will provide many hours of quality exercise to make you feel better, look better and enjoy life to its fullest.

Yes, it's a proven fact that a regular exercise program can improve your physical and mental health. Too often, our busy lifestyles limit our time and opportunity to exercise. The **INSTRIDE PLUS** provides a convenient and simple method to begin your assault on getting your body in shape and achieving a happier and healthier lifestyle.

Before reading further, please review the drawing below and familiarize yourself with the parts that are labeled.

Read this manual carefully before using the **INSTRIDE PLUS**.

Although Stamina tries to manufacture its products with the finest materials and uses the highest standards of manufacturing, occasionally a part that does not fit, is the incorrect size, or is otherwise inappropriate is found. Even with the highest inspection and quality controls in place these things will happen occasionally. Please do not return the product. For your convenience, Stamina has a Customer Service Department with a toll-free number. If a part is missing, does not fit, is the incorrect size, or is otherwise inappropriate, please call 1 (800) 375-7520 (in the U.S.) between 8:00 A.M. and 5:00 P.M. Central Time, Monday through Friday. Our operators will be able to assist you with your problem and the parts will be mailed directly to your house.

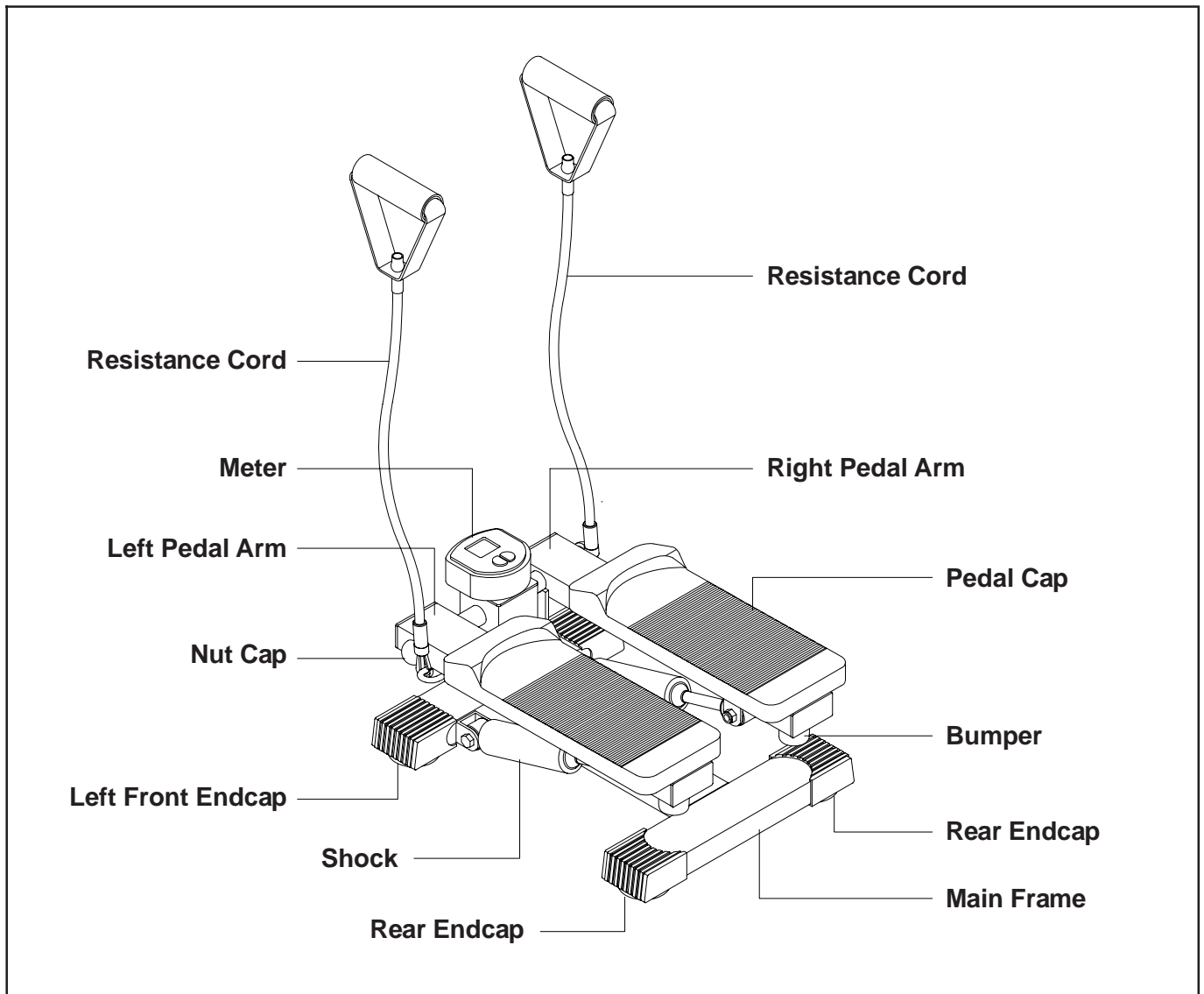

ASSEMBLY INSTRUCTIONS

Place all parts from the box in a cleared area and position them on the floor in front of you. Remove all packing materials from your area and place them back into the box. Do not dispose of the packing materials until assembly is completed. Read each step carefully before beginning. If you are missing a part please call our toll-free number for assistance **1 (800) 375-7520** or e-mail us at:

parts@staminaproducts.com

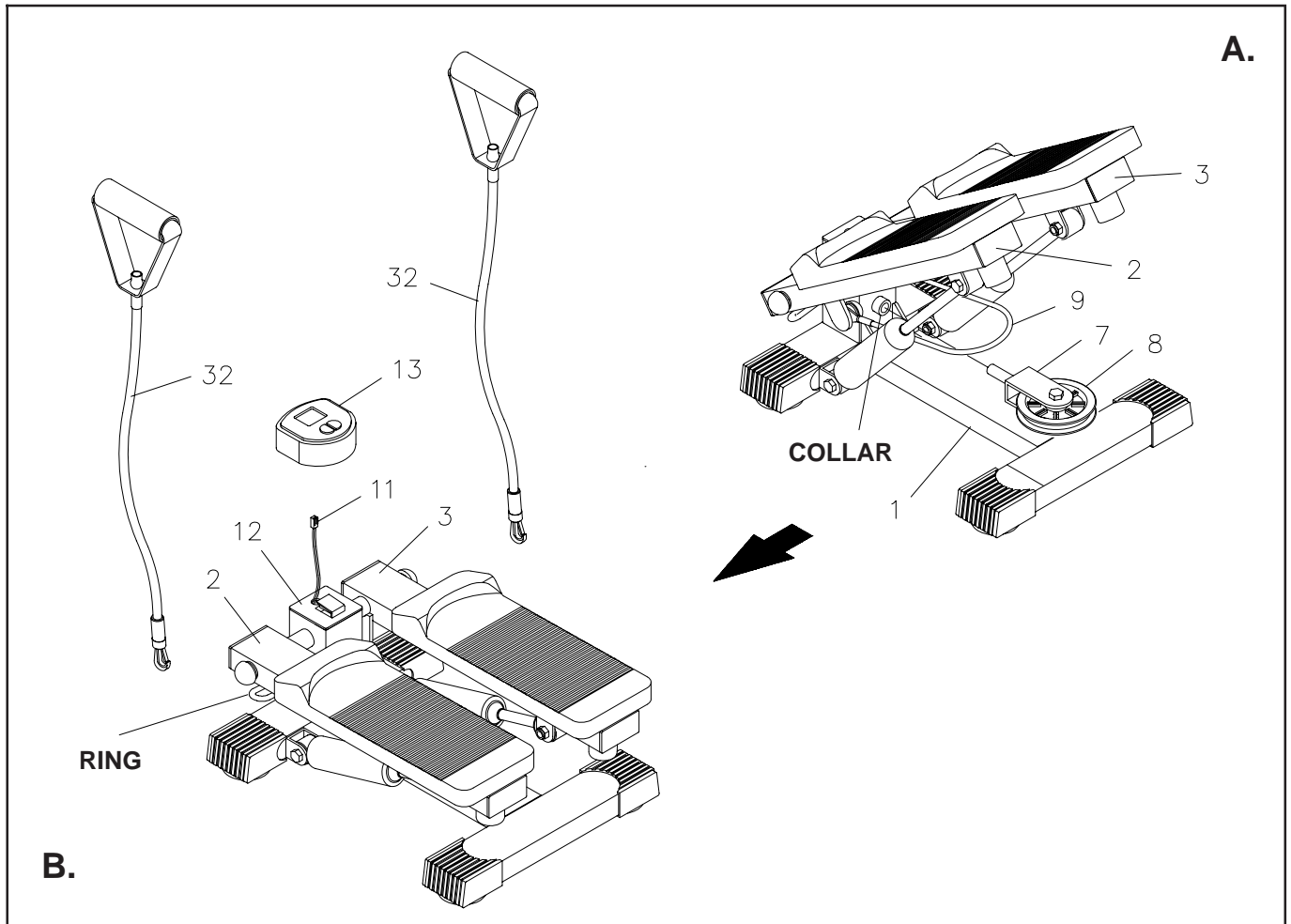

STEP 1

Lift up the **LEFT** and **RIGHT PEDAL ARMS(2, 3)**. Insert the **PULLEY BRACKET(7)** into the Collar on the **MAIN FRAME(1)**. Wrap the **CABLE(9)** around the **PULLEY(8)** and press the two **PEDAL ARMS(2, 3)** down. Refer to illustration A.

NOTE: Always make sure that the **CABLE(9)** is properly seated in the groove on the **PULLEY(8)** before using the **INSTRIDE**.

STEP 2

Refer to illustration B. Hook the **RESISTANCE CORDS(32)** onto the Rings in the **LEFT** and **RIGHT PEDAL ARMS(2, 3)**.

Install one "AAA" battery into the back of the **METER(13)**, one battery included. Plug the **SENSOR WIRE(11)** into the **METER(13)**, then slide the **METER(13)** onto the **MOUNTING CAP(12)**.

NOTE: 1. Please be careful not to damage the **SENSOR WIRE(11)** when attaching the **METER(13)**.

2. See page 7 for detailed battery installation instructions.

SET UP INSTRUCTIONS

Place the **INSTRIDE PLUS** in the area where it will be used. It is recommended that the **INSTRIDE PLUS** be placed on an equipment mat. The max. operation dimensions of **INSTRIDE PLUS** is approximately 17 3/8" long x 11 3/4" tall x 12 3/8" wide. (These dimensions may vary up to one inch.) An area 6 feet wide x 6 feet long is required for safe operation of the **INSTRIDE PLUS**. Make sure that adequate space is available for access to and passage around the **INSTRIDE PLUS**.

LEVELING: Adjust the location of **INSTRIDE PLUS** on the floor to make the stepper sets on the floor without rocking.

MOVING: Grasp the Front and Rear Stabilizers to move the **INSTRIDE PLUS**. Do not use the Pedal Arms to move the **INSTRIDE PLUS**. The Pedal Arms will move and the Shock may pinch your hand or fingers.

FUNCTION INSPECTION

NOTE: Always make sure that the **CABLE(9)** is properly seated in the groove on the **PULLEY(8)** before using the **INSTRIDE PLUS**.

Visually inspect the **INSTRIDE PLUS** to verify that assembly is as shown in the above illustrations. Check the function of the **INSTRIDE PLUS**. Stand on the foot pedals and slowly move your highest foot downward and follow the natural path of the machine. The Shocks should provides resistance for your workout.

Inspect the **RESISTANCE CORDS(32)** for nicks and cuts. Replace damaged **RESISTANCE CORDS(32)**.

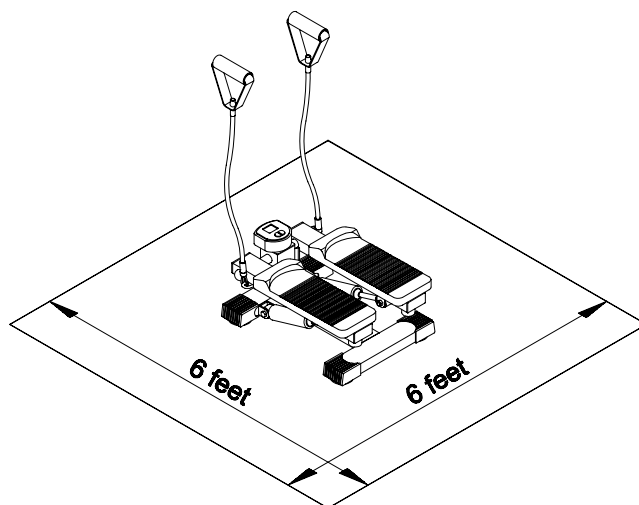

STORAGE

1. To store the **INSTRIDE PLUS** simply keep it in a clean dry place.
2. The min. rest dimesions of **INSTRIDE PLUS** is approximately 17 3/8" long x 8 1/4" tall x 12 3/8" wide. These dimensions will vary. Please measure your **INSTRIDE PLUS** if exact dimensions are needed.
3. Grasp the Front and Rear Stabilizer to move the **INSTRIDE PLUS**. Do not use the Pedal Arms to move the **INSTRIDE PLUS**.
4. To avoid damage to the electronics, remove the battery before storing the **INSTRIDE PLUS** for one year or more.

MAINTENANCE

The safety and integrity designed into the **INSTRIDE PLUS** can only be maintained when the **INSTRIDE PLUS** is regularly examined for damage and wear. Special attention should be given to the following:

1. Inspect the **RESISTANCE CORDS(32)** for nicks and cuts. Replace damaged **RESISTANCE CORDS(32)**.
2. Verify that the Shocks provides resistance. The Shocks should provide many years of use.
3. Shocks on steppers get **HOT** during use. To avoid burns, do not touch the shocks until they have time to cool.
4. Verify that the Warning Label is in place and easy to read. Call Stamina Products immediately (1-800-375-7520) for a replacement Warning Label if the Warning Label is missing or damaged.
5. It is the sole responsibility of the user/owner to ensure that regular maintenance is performed.
6. Worn or damaged components shall be replaced immediately or the **INSTRIDE PLUS** removed from service until repair is made.
7. Only Stamina Products supplied components shall be used to maintain/repair the **INSTRIDE PLUS**.
8. Keep your **INSTRIDE PLUS** clean by wiping with an absorbent cloth after use.

USING THE ELECTRONIC METER

POWER ON : Pedal movement or push any button.

POWER OFF : Automatic shut off after 4 minutes of inactivity.

FUNCTION BUTTONS:

MODE : Push to select the function of the lower readout.

RESET : To reset all functions to zero.

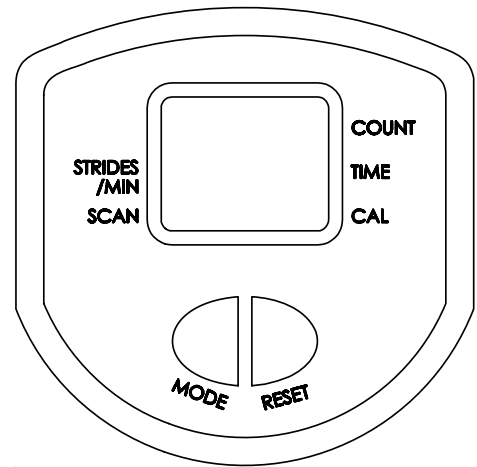

FUNCTIONS:

COUNT : Upper readout displays the total number of strides you have taken, from zero to 9999 strides.

SCAN: Automatically scans each function of **TIME**, **CALORIE**, **STRIDES/MIN** in sequence with change every 5 seconds.

TIME: Displays the riding time, from 1 sec up to 99:59 minutes.

STRIDES/MIN: Displays the rate of strides per minute.

CALORIE: Displays the calorie consumption, from zero to 9999 cal.

The calorie readout is an estimate for an average user. It should be used only as a comparison between workouts on this unit.

NOTE: The meter will stop counting time automatically after 4 seconds of inactivity. All function values will be kept. Restart the meter by moving the pedals.

HOW TO INSTALL AND REPLACE BATTERY:

1. Open the Battery Door on the back of the meter.
2. The meter operates with one AAA battery, one battery included. Refer to the illustration to install or replace the battery.

NOTE:

1. Rechargeable batteries are not recommended.

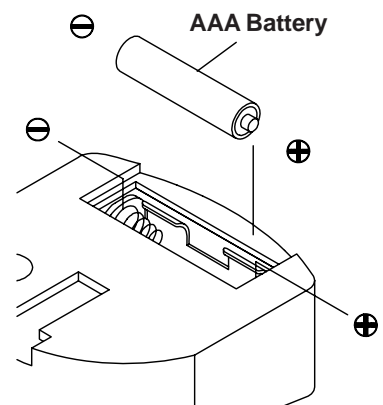

CONDITIONING GUIDELINES

How you begin your exercise program depends on your physical condition. If you have been inactive for several years, or are severely overweight, you must start slowly and increase your time on the **INSTRIDE PLUS** gradually: a few minutes per workout.

Initially, you may be able to exercise only for a few minutes in your target zone, however, your aerobic fitness will improve over the next six to eight weeks. Don't be discouraged if it takes longer. It's important to work at your own pace. Ultimately, you'll be able to exercise continuously for 30 minutes. The better your aerobic fitness, the harder you will have to work to stay in your target zone. Please remember these essentials:

- Have your doctor review your training and diet programs to advise you of a workout routine you should adopt.
- Begin your training program slowly with realistic goals that have been set by you and your doctor.
- Monitor your pulse frequently. Establish your target heart rate base on your age and condition.
- Set up your **INSTRIDE PLUS** on a flat, even surface at least 3 feet from walls and furniture.

EXERCISE INTENSITY

To maximize the benefits of exercising, it is important to exercise with the proper intensity. The proper intensity level can be found by using your heart rate as a guide. For effective aerobic exercise, your heart rate should be maintained at a level between 70% and 85% of your maximum heart rate as you exercise. This is known as your target zone. You can find your target zone in the table below. Target zones are listed for both unconditioned and conditioned persons according to age.

AGE	UNCONDITIONED TARGET ZONE (BEATS/MIN.)	CONDITIONED TARGET ZONE (BEATS/MIN.)
20	138~167	133~162
25	136~166	132~160
30	135~164	130~158
35	134~162	129~156
40	132~161	127~155
45	131~159	125~153
50	129~156	124~150
55	127~155	122~149
60	126~153	121~147
65	125~151	119~145
70	123~150	118~144
75	122~147	117~142
80	120~146	115~140
85	118~144	114~139

During the first few months of your exercise program, keep your heart rate near the low end of your target zone as you exercise. After a few months, your heart rate can be increased gradually until it is near the middle of your target zone as you exercise.

To measure your heart rate manually, stop exercising but continue moving your legs or walking around and place two fingers on your wrist. Take a six-second heartbeat count and multiply the results by 10 to find your heart rate. For example, if your six-second heartbeat count is 14, your heart rate is 140 beats per minute. (A six-second count is used because your heart rate will drop rapidly when you stop exercising.) Adjust the intensity of your exercise until your heart rate is at the proper level.

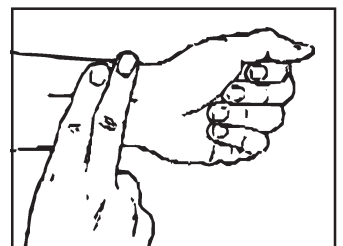

WARM-UP and COOL-DOWN

Warm-up The purpose of warming up is to prepare your body for exercise and to minimize injuries. Warm up for two to five minutes before strength-training or aerobic exercising. Perform activities that raise your heart rate and warm the working muscles. Activities may include brisk walking, jogging, jumping jacks, jump rope, and running in place

Stretching Stretching while your muscles are warm after a proper warm-up and again after your strength or aerobic training session is very important. Muscles stretch more easily at these times because of their elevated temperature, which greatly reduces the risk of injury. Stretches should be held for 15 to 30 seconds. Do not bounce.

Suggested Stretching Exercises

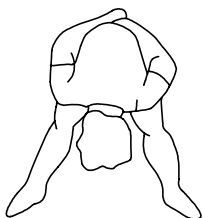

Lower Body Stretch

Place feet shoulder-width apart and lean forward. Keep this position for 30 seconds using the body as a natural weight to stretch the backs of the legs. **DO NOT BOUNCE!** When the pull on the back of the legs lessen, try a lower position gradually.

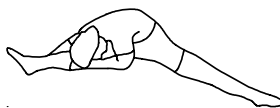

Floor Stretch

While sitting on the floor, open the legs as wide as possible. Stretch the upper body toward the knee on the right leg by using your arms to pull your chest to your thighs. Hold this stretch 10 to 30 seconds. **DO NOT BOUNCE!** Do this stretch 10 times. Repeat the stretch with the left leg.

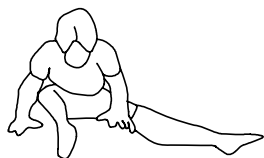

Bent Torso Pulls

While sitting on the floor, have legs apart one leg straight and one knee bent. Pull the chest down to touch the thigh on the leg that is bent and twist at the waist. Hold this position at least 10 seconds. Repeat 10 times on each side.

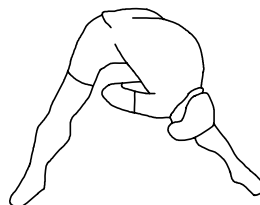
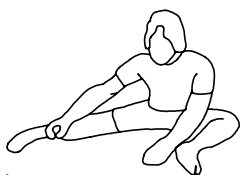

Bent Over Leg Stretch

Stand with feet shoulder-width apart and lean forward as illustrated. Using the arms, **gently** pull the upper body towards the right leg. Let the head hang down. **DO NOT BOUNCE!** Hold the position a minimum of 10 seconds. Repeat pulling the upper body to the left leg. Do this stretch several times slowly.

Remember always to check with your physician before starting any exercise program.

Cool-Down The purpose of cooling down is to return the body to its normal, or near normal, resting state at the end of each exercise session. A proper cool-down slowly lowers your heart rate and allows blood to return to the heart. Your cool-down should include the stretches listed above and should be completed after each strength-training session.

PRODUCT PARTS DRAWING

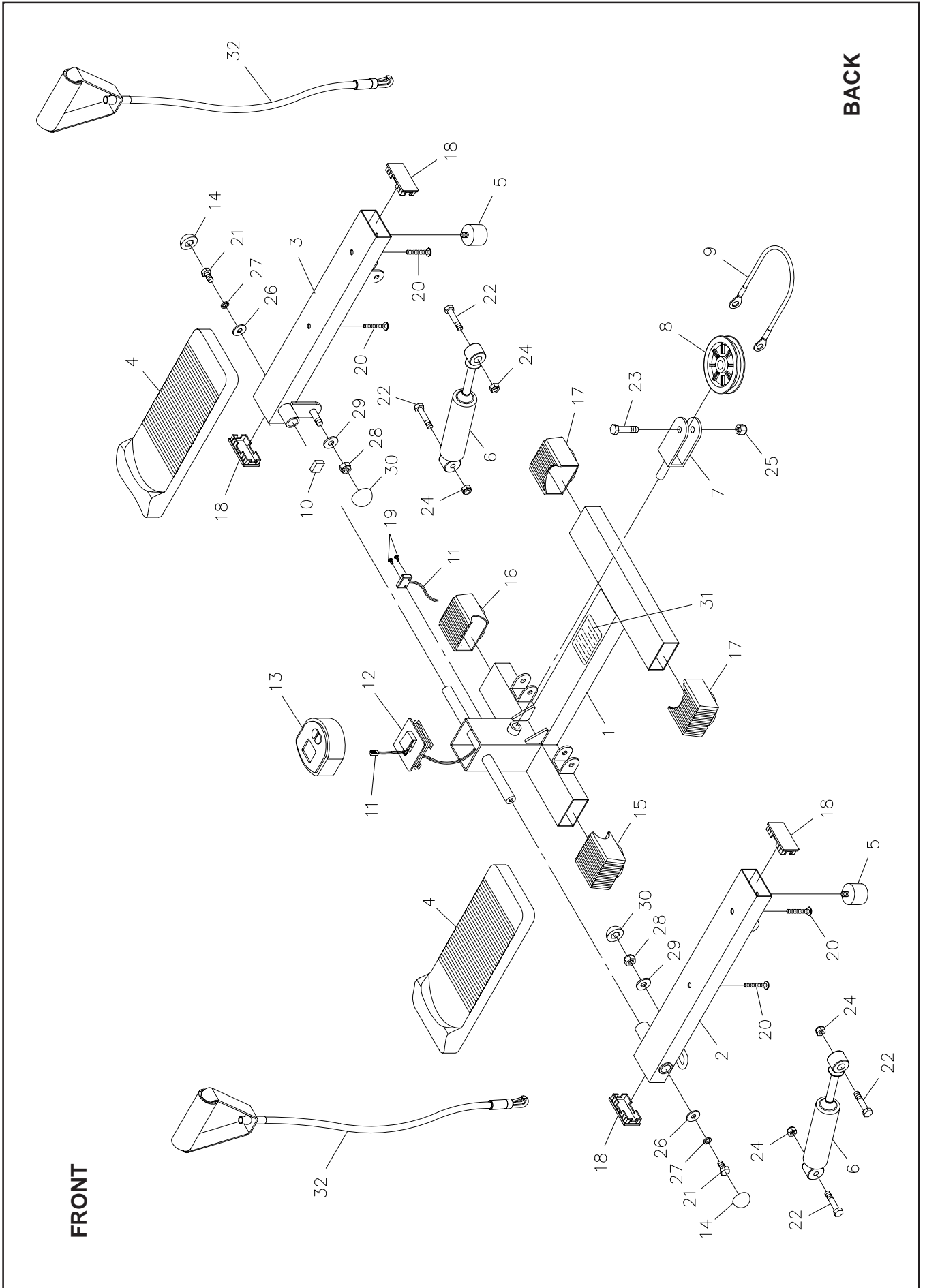

PARTS LIST

DIAGRAM#	PART NAME	QTY
1	Main Frame	1
2	Left Pedal Arm	1
3	Right Pedal Arm	1
4	Pedal Cap	2
5	Bumper	2
6	Shock	2
7	Pulley Bracket	1
8	Pulley	1
9	Cable	1
10	Magnet	1
11	Sensor Wire	1
12	Mounting Cap (60 x 60mm)	1
13	Meter	1
14	Nut Cap (M8)	2
15	Left Front Endcap (30 x 60mm)	1
16	Right Front Endcap (30 x 60mm)	1
17	Rear Endcap (30 x 60mm)	2
18	Rectangular Plug (30 x 60mm)	4
19	Screw, Round Head (M3 x 10mm)	2
20	Bolt, Round Head (M6 x 1 x 38mm)	4
21	Bolt, Hex Head (M8 x 1.25 x 16mm)	2
22	Bolt, Hex Head (M8 x 1.25 x 38mm)	4
23	Bolt, Hex Head (3/8" - 16 x 1 9/16")	1
24	Nylock Nut (M8 x 1.25)	4
25	Nylock Nut (3/8" - 16)	1
26	Washer (M8)	2
27	Lock Washer (M8)	2
28	Thin Nylock Nut (3/8" - 16 x 1/4" thick)	2
29	Nylon Washer (3/8")	2
30	Nut Cap (3/8")	2
31	Warning Label	1
32	Resistance Cord	2
33	Manual	1

WARRANTY

Stamina Products, Inc. warrants that this product will be free from defects in materials and workmanship under normal use, service and proper operation for a period of 90 days on the parts and 5 years on the frame from the date of the original purchase from an authorized retailer. **THIS WARRANTY SHALL NOT APPLY TO ANY PRODUCT WHICH HAS BEEN SUBJECT TO COMMERCIAL USE, ABUSE, MISUSE, ALTERATION OF ANY TYPE OR CAUSE OR TO ANY DEFECT OR DAMAGE CAUSED BY REPAIR, REPLACEMENT, SUBSTITUTION OR USE WITH PARTS OTHER THAN PARTS PROVIDED BY STAMINA PRODUCTS, INC.** Commercial use includes use of the product in athletic clubs, health clubs, spas, gymnasiums, exercise facilities, and other public or semipublic facilities whether or not the product's use is in furtherance of a profit making enterprise, and all other use which is not for personal, family, or household purposes.

To implement this limited warranty, send a written notice stating your name, date, and place of purchase and a brief description of the defect along with your receipt to **Stamina Products, Inc. P.O. Box 1071, Springfield Missouri, USA, 65801-1071** or call us at **1 (800) 375-7520**. If the defect is covered under this limited warranty, you will be requested to return the product or part to us for free repair or replacement at our option. **NO ACTION FOR BREACH OF THIS LIMITED WARRANTY MAY BE COMMENCED MORE THAN ONE (1) YEAR AFTER THE DATE THE ALLEGED BREACH WAS OR SHOULD HAVE BEEN DISCOVERED. NO ACTION FOR BREACH OF ANY IMPLIED WARRANTY MAY BE COMMENCED MORE THAN ONE (1) YEAR AFTER DELIVERY OF THE PRODUCT TO THE PURCHASER.** This limited warranty is not transferable. **IF ANY PART OF THE PRODUCT IS NOT IN COMPLIANCE WITH THIS LIMITED WARRANTY OR ANY IMPLIED WARRANTY, THE REMEDY OF REPAIR OR REPLACEMENT IS THE EXCLUSIVE REMEDY AVAILABLE TO YOU.** In the event that the purchaser makes any claim under this limited warranty or any implied warranty, the Warrantor reserves the right to require the product to be returned for inspection, at the purchaser's expense, to the Warrantor's premises in Springfield, Missouri. Return of the enclosed warranty registration card is not required for warranty coverage, but is merely a way of establishing the date and place of purchase.

Stamina Products, Inc. **SHALL NOT BE LIABLE FOR THE LOSS OF USE OF ANY PRODUCT, LOSS OF TIME, INCONVENIENCE, COMMERCIAL LOSS OR ANY OTHER INDIRECT, CONSEQUENTIAL, SPECIAL OR INCIDENTAL DAMAGES DUE TO BREACH OF THE ABOVE WARRANTY OR ANY IMPLIED WARRANTY.**

This limited warranty is the only written or express warranty given by Stamina Products, Inc. This warranty gives you specific legal rights, and you may also have other legal rights which vary from state to state. **ANY OTHER RIGHT WHICH YOU MAY HAVE, INCLUDING ANY IMPLIED WARRANTY OR MERCHANTABILITY OR FITNESS FOR A PARTICULAR PURPOSE, IS LIMITED IN DURATION TO THE DURATION OF THIS WARRANTY.**

The laws in some jurisdictions restrict the rights of manufacturers and distributors of consumer goods to disclaim or limit implied warranties and consequential and incidental damages with respect thereto. If any such law is found to be applicable, the foregoing disclaimers and limitations of and on implied warranties and consequential and incidental damages with respect thereto shall be disregarded and shall be deemed not to have been made to the extent necessary to comply with such legal restriction.

NOTES

