

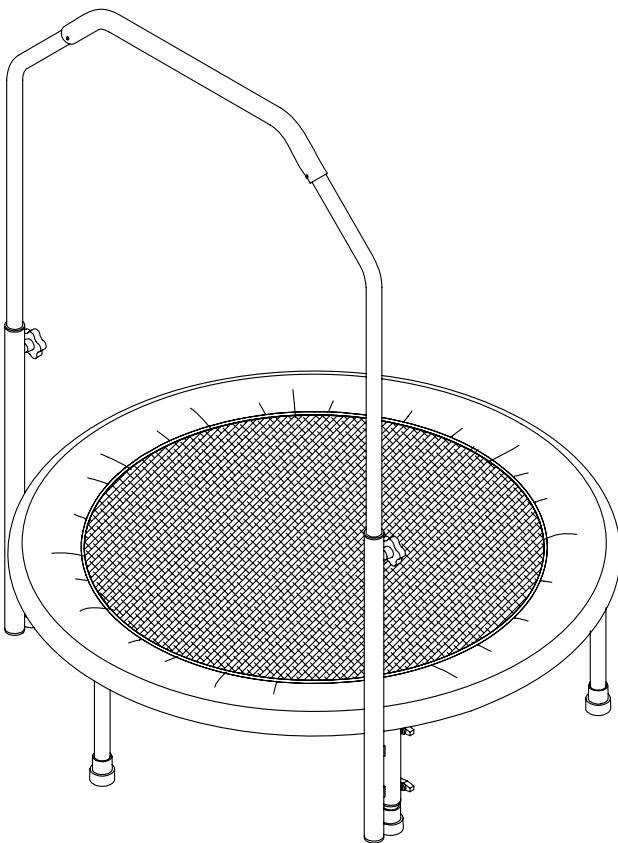

# Owner's Manual

## Assembly, Installation, Care, Maintenance, and Use Instructions.

**WARNING:** Read these materials prior to assembling and using this trampoline.



Product May Vary Slightly From Pictured.

This Product is Produced Exclusively by



2040 N. ALLIANCE, SPRINGFIELD, MO 65803

Customer Service Number

1 (800) 375-7520

[www.staminaproducts.com](http://www.staminaproducts.com)

© 2004 Stamina Products, Inc.  
2005, 12

### ! WARNING !

1. DO NOT attempt or allow somersaults. Landing on the head or neck can cause serious injury, paralysis, or death even when landing in the middle of the bed.
2. Do not allow more than one person on the trampoline. Use by more than one person at the same time can result in serious injury.
3. Use trampoline only with mature knowledgeable supervision.
4. Exercise can present a health risk. Consult a physician before beginning any exercise program with this equipment.
5. If you feel faint or dizzy, immediately discontinue use of this equipment.
6. Serious bodily injury can occur if this equipment is not assembled and used correctly.
7. Serious bodily injury can occur if all instructions are not followed.
8. Keep others and pets away from equipment when in use.
9. Always make sure all parts are tightened prior to each use.

### WARNING:

1. Weight on this trampoline should not exceed 250 lbs.
2. This trampoline is not recommended for children.

When calling for parts or service,  
please specify the following number.

35-1655B

Licensed Under U.S. Patent

6,237,169B1

Other Patents Applied and Are Pending

MADE IN CHINA

# CALL US FIRST



## CUSTOMER SERVICE NUMBER 1 (800) 375-7520

---

**THANK YOU FOR PURCHASING THE  
INTONE JOGGER**

Simply follow the few assembly instructions set forth in this manual. Within a few minutes you will be getting your body into shape and on your way to achieving a happier and healthier lifestyle.

Should you have any questions, please call our Customer Service Department toll-free number, 1 (800) 375-7520, Monday - Friday, 8:00 A.M. - 5:00 P.M., Central Time.

### TABLE OF CONTENTS

	Page
Safety Instructions	3
Before You Begin	4
Product Parts Drawing	4
Assembly Instructions	5
Installation Instructions	7
Care and Maintenance Instructions	7
Use Instructions	8
Workout Program	9
Warm-up and Cool-Down	10
Basic Workout	11
Warranty	13
Notes	14
Fax/Mail Ordering Form	15

# SAFETY INSTRUCTIONS

**WARNING: To reduce the risk of serious injury, read the following Safety Instructions before using the INTONE JOGGER trampoline.**

1. Misuse and abuse of this trampoline is dangerous and can cause serious injuries.
2. Trampolines, being rebounding devices, propel the performer to unaccustomed heights and into a variety of body movements.
3. When unfolding or folding the trampoline, the rails will try to spring into the folded position.
4. Use two or more strong people to unfold and fold the **INTONE JOGGER** trampoline.
5. All purchasers and all persons using the **INTONE JOGGER** trampoline must become familiar with the manufacturer's recommendations for proper assembly, use and care of the **INTONE JOGGER** trampoline, as well as being alert to the performer's own limitations in the execution of trampoline skills. Assembly Instructions, Safety Instructions, Trampoline Fundamentals and Warning Labels are included to promote safe, enjoyable use of the **INTONE JOGGER** trampoline.
6. The owner and supervisors of the trampoline are responsible to make all users aware of the Safety Instructions and practices in the use instructions.
7. Place the **INTONE JOGGER** trampoline on a level surface before use.
8. Use the **INTONE JOGGER** trampoline in a well lighted area. Artificial illumination may be required for indoor or shady areas.
9. Do not place the **INTONE JOGGER** trampoline on an elevated surface. The **INTONE JOGGER** trampoline should be at floor level or ground level.
10. Inspect your **INTONE JOGGER** trampoline before each use. Make sure the safety pad is in place. Replace any worn, defective, or missing parts.
11. Make sure the floor or ground around the **INTONE JOGGER** trampoline is clear of all objects that may cause injury if you step on them when dismounting.
12. Adequate overhead clearance is essential. Provide adequate clearance for ceilings, ceiling lights, ceiling fans, wires and tree limbs. Failure to provide adequate head clearance can result in head or neck injury. A minimum of 24 feet is recommended for outdoor trampolines.
13. Do not allow children to use the **INTONE JOGGER** trampoline. The **INTONE JOGGER** trampoline is not a toy, it is for use by adults only. Use the trampoline only with mature knowledgeable supervision.  
**NOTE:** The **TRAMPOLINE USE INSTRUCTIONS** sign is a standard sign that is supplied to comply with **ASTM F381**. This sign indicates that trampolines are suitable for use by children over six years of age. However, the **INTONE JOGGER** trampoline is not recommended for children of any age.
14. Lateral clearance is essential. Place the **INTONE JOGGER** trampoline away from walls, structures, fences, play areas, furniture, and other exercise equipment. Maintain a clear space on all sides of the trampoline.
15. Keep small children and pets away from the **INTONE JOGGER** trampoline at all times including use and assembly of the **INTONE JOGGER** trampoline.
16. The weight limit on the **INTONE JOGGER** trampoline is 250 pounds.
17. Do not use the **INTONE JOGGER** trampoline with socks only. Good traction is very important when mounting, using, and dismounting the **INTONE JOGGER** trampoline. Bare feet are acceptable but we recommend good footwear with rubber non-skid soles such as walking, running or cross-training shoes.
18. Wear appropriate clothing when exercising; do not wear loose clothing that could become caught in the **INTONE JOGGER** trampoline.
19. The **INTONE JOGGER** trampoline should be used by only one person at a time.
20. Remove any obstructions from beneath the **INTONE JOGGER** trampoline.
21. The surface of the bed should be dry.
22. Be careful to maintain your balance when mounting, using, dismounting, or assembling the **INTONE JOGGER** trampoline. Loss of balance may result in a fall and serious bodily injury.
23. Do not step on the safety pad when mounting, using or dismounting the **INTONE JOGGER** trampoline.
24. Do not attempt any gymnastic or acrobatic maneuvers on the **INTONE JOGGER** trampoline.
25. Stop exercising before attempting to dismount the **INTONE JOGGER** trampoline. To avoid sprains and broken bones, come to a complete stop before dismounting.
26. Use the **INTONE JOGGER** trampoline only as described in this manual.
27. Always store the **INTONE JOGGER** trampoline indoors in a dry place.
28. Secure the **INTONE JOGGER** trampoline against unauthorized and unsupervised use.
29. Remove the safety pad before folding the **INTONE JOGGER** trampoline for storage. Failure to remove the safety pad before folding will result in damage to the safety pad.

**WARNING: Before starting any exercise or conditioning program you should consult with your personal physician to see if you require a complete physical exam. This is especially important if you are over the age of 35, have never exercised before, are pregnant, or suffer from any illness. READ AND FOLLOW THE SAFETY INSTRUCTIONS. FAILURE TO FOLLOW THESE INSTRUCTIONS CAN RESULT IN SERIOUS BODILY INJURY.**

## BEFORE YOU BEGIN

Thank you for choosing the **INTONE JOGGER** trampoline. We take great pride in producing this quality product and hope it will provide many hours of quality exercise to make you feel better, look better and enjoy life to its fullest.

Yes, it's a proven fact that a regular exercise program can improve your physical and mental health. Too often, our busy lifestyles limit our time and opportunity to exercise. The **INTONE JOGGER** trampoline provides a convenient and simple method to begin your assault on getting your body in shape and achieving a happier and healthier lifestyle.

Before reading further, please review the drawing below and familiarize yourself with the parts that are labeled.

Read this manual carefully before using the **INTONE JOGGER** trampoline.

Although Stamina tries to manufacture its products with the finest materials and uses the highest standards of manufacturing, occasionally a part that does not fit, is the incorrect size, or is otherwise inappropriate is found. Even with the highest inspection and quality controls in place these things will happen occasionally. Please do not return the product. For your convenience, Stamina has a Customer Service Department with a toll-free number. If a part is missing, does not fit, is the incorrect size, or is otherwise inappropriate, please call 1 (800) 375-7520 (in the U.S.) between 8:00 A.M. and 5:00 P.M. Central Time, Monday through Friday. Our operators will be able to assist you with your problem and the parts will be mailed directly to your house.

## PRODUCT PARTS DRAWING

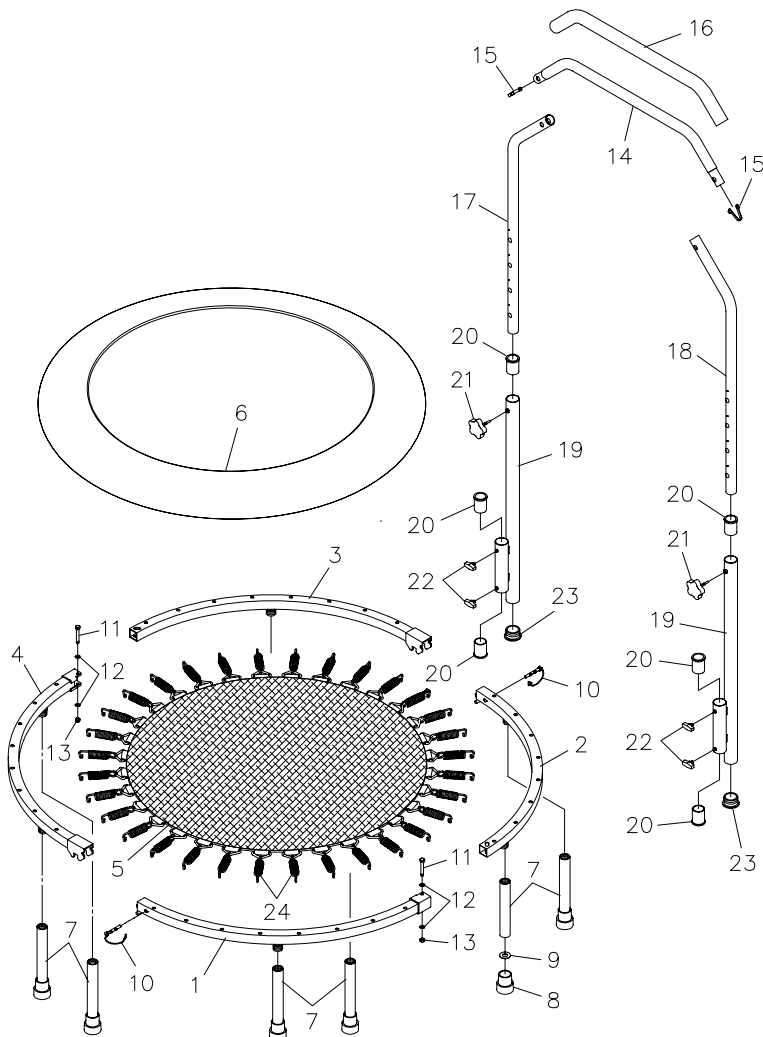

Part No. and Description	Qty
1 Rail A	1
2 Rail B	1
3 Rail C	1
4 Rail D	1
5 Mat	1
6 Safety Pad	1
7 Leg	6
8 Leg Cap	6
9 Cap Washer	6
10 Secure Pin	2
11 Bolt, Round Head(1/4"-20 x 1 3/4")	2
12 Washer (1/4")	4
13 Nylock Nut (1/4"-20)	2
14 Top Handrail	1
15 Button Pin	2
16 Foam Grip	1
17 Left Handrail	1
18 Right Handrail	1
19 Handrail Support	2
20 Bushing	6
21 Adjustment Knob	2
22 Locking Knob	4
23 Round Plug (1 1/4")	2
24 Spring	32
25 Manual	1
26 Use Instructions Sign (Not Shown)	1
27 Video Tape	1

## ASSEMBLY INSTRUCTIONS

Place all parts from the box in a cleared area and position them on the floor in front of you. Remove all packing materials from your area and place them back into the box. Do not dispose of the packing materials until assembly is completed. Read each step carefully before beginning. If you are missing a part please call our toll-free number for assistance **1 (800) 375-7520** or e-mail us at: **parts@staminaproducts.com**

### WARNING :

1. Keep children away from the **INTONE JOGGER** trampoline during assembly.
2. Keep fingers away from the ends of the rails in the hinge area when unfolding the **INTONE JOGGER** trampoline. The **INTONE JOGGER** trampoline will snap into the unfolded position. Serious injury can occur if fingers are caught between the ends of the **RAILS**.
3. When unfolding the **INTONE JOGGER** trampoline, the **RAILS** will try to spring back to the folded position if they are released before they snap into place.
4. The **SAFETY PAD(6)** must be installed before using the **INTONE JOGGER** trampoline.
5. Use two or more strong people to unfold and fold the **INTONE JOGGER** trampoline.

**NOTE 1 :** Check all springs **BEFORE** assembly. If any spring is not attached or damaged, please follow the following process to attach or replace the spring:

- A. Find the open end of the **SPRING(24)** and hook this end into the hole on the Rail. Refer to illustration A.
- B. Swing the **SPRING(24)** to face inside of the trampoline. Refer to illustration B.
- C. Slide the metal loop on the **MAT(5)** into the spring hook as shown in the illustration C.

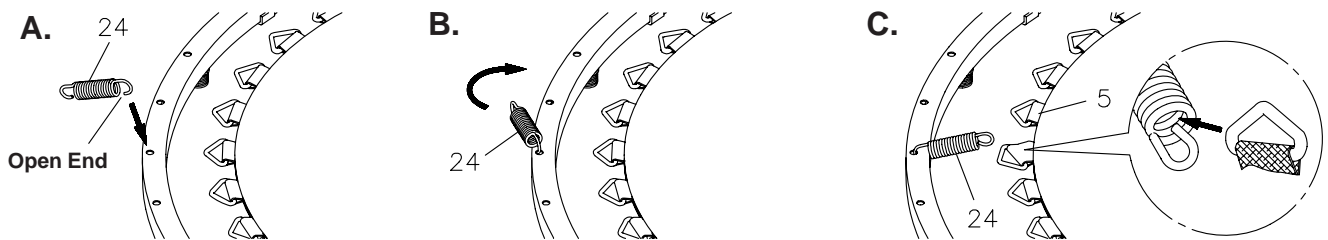

### NOTE 2:

**BEFORE** assembly, verify that the **SECURE PINS(10)** are properly inserted in the Frame Rail. The two protrusions must be assembled inside the Frame Rail as shown in the SECTION VIEW of the illustration. Otherwise, it could damage the **SECURE PINS(10)** during Assembly Step 3.

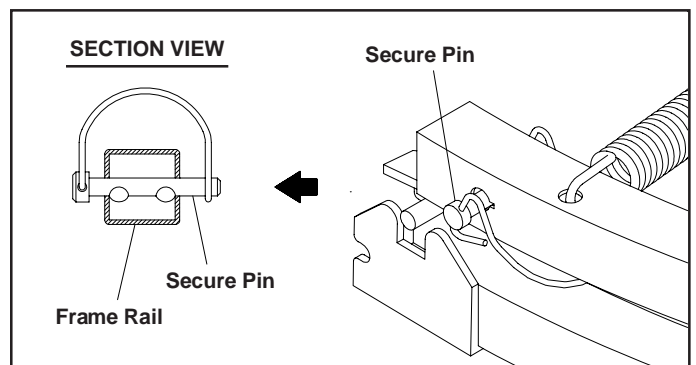

**STEP 1:** Lay the trampoline on the floor and open the rails. The trampoline will look as shown in illustration 1.

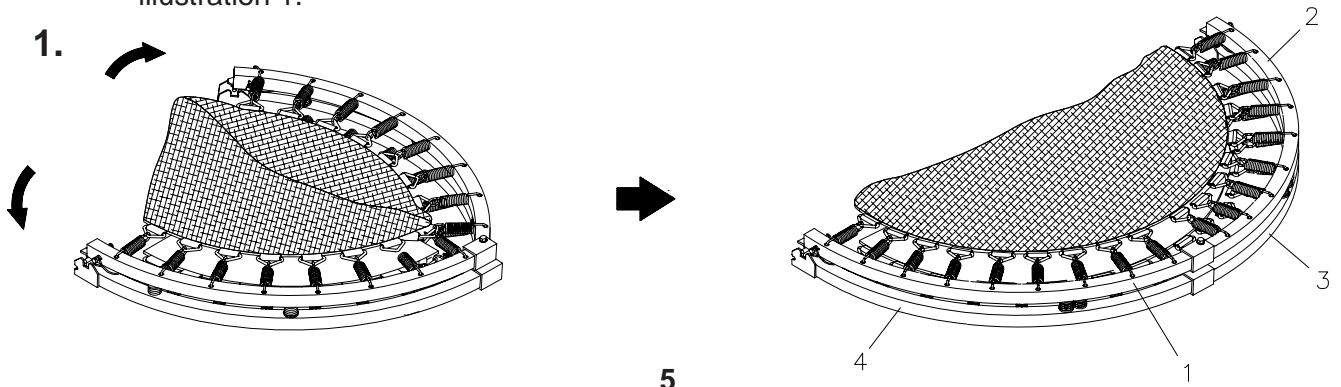

## ASSEMBLY INSTRUCTIONS

**NOTE:** Make sure the **SECURE PINS(10)** are inserted into the ends of **RAILS(1, 2)** and properly secured by the Wire Ring. Both ends of the **SECURE PINS(10)** should have approximately 1/8 inch between the **RAILS(1, 2)** and the Wire Ring. Refer to illustration 2.

**STEP 2:** Place the ends of **RAILS(1, 2)** in the **BRACKET GUIDES** on the ends of **RAILS(3, 4)**. Make sure the rods on the ends of **RAILS(1, 2)** are fully inserted into the slots in **BRACKET GUIDES** on the ends of **RAILS(3, 4)**. Refer to illustration 2.

**STEP 3:** Hold **RAILS(3, 4)** and push down on **RAILS(1, 2)** to unfold the **INTONE JOGGER** trampoline to the flat position. The **RAILS(1, 4)** and **RAILS(2, 3)** should snap together and be locked by the **SECURE PINS(10)** when you reach the flat position. Refer to illustration 2.

**WARNING:** Keep fingers away from the ends of the rails in the hinge area when unfolding the **INTONE JOGGER** trampoline. Serious injury can occur if fingers are caught between the ends of the **RAILS**.

**STEP 4:** Slide the **SAFETY PAD(6)** over the rail frame. Make sure the holes in **SAFETY PAD(6)** fit over the threaded connectors properly. Refer to illustration 3.

**HINT:** Install one hole over a threaded connector. The next hole installed should be on the connector on the opposite side of the trampoline.

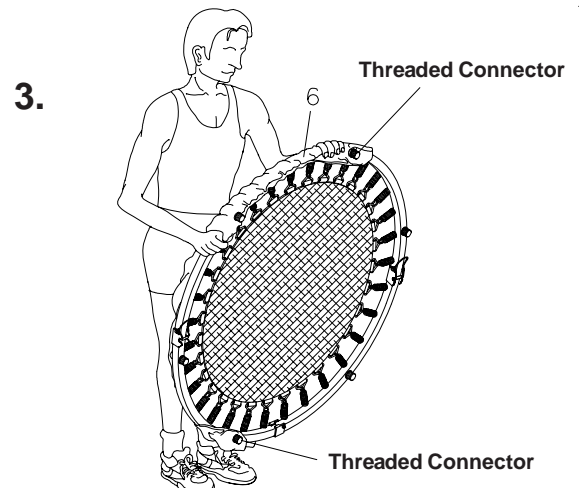
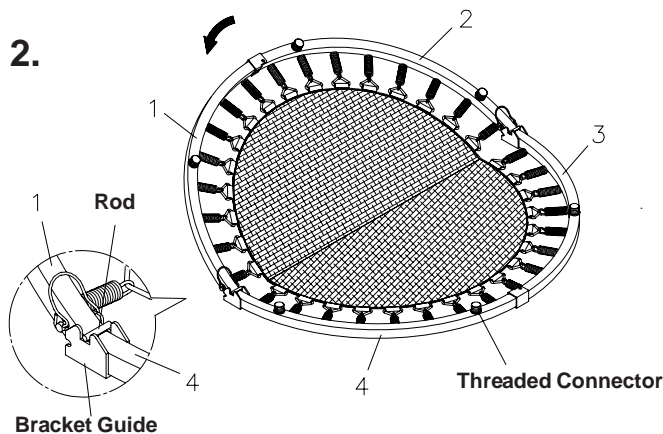

**STEP 5:** The two **LEGS(7)** with a Warning Label must be on opposite sides of the **INTONE JOGGER**. Screw one of the **LEGS(7)** with a Warning Label onto a threaded connector on the rail frame. Attach the other **LEG(7)** with a Warning Label to the threaded connector directly opposite the other **LEG(7)** with a Warning Label. Screw the other four **LEGS(7)** onto the threaded connectors on the rail frame. Refer to illustration 4.

**STEP 6:** Place the trampoline in the normal use position. Remove the **LEG CAPS(8)** from two of the four **LEGS(7)** without a Warning Label. Slide the **HANDRAIL SUPPORTS(19)** onto the two **LEGS(7)** as shown in illustration 5. Press the **LEG CAPS(8)** back on these **LEGS(7)**. Do not tighten the **LOCKING KNOBS(22)** until **STEP 8**.

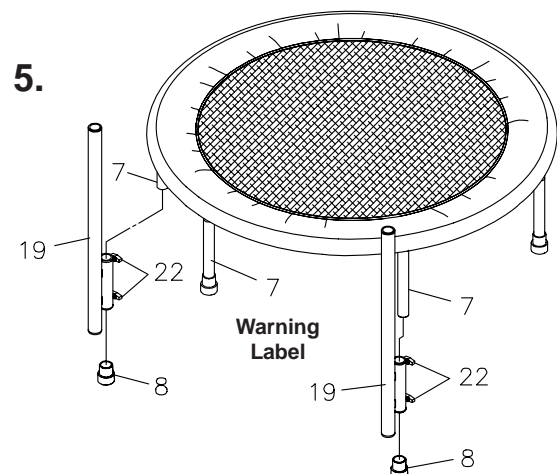
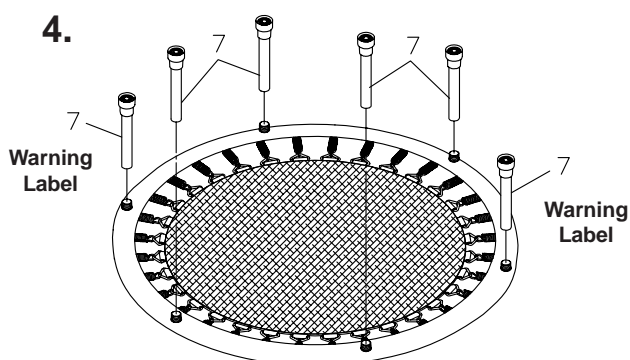

## ASSEMBLY INSTRUCTIONS

**STEP 7:** Insert both ends of the **TOP HANDRAIL(14)** into the **LEFT** and **RIGHT HANDRAILS(17, 18)** and lock with the **BUTTON PINS(15)**. Make the holes in the **LEFT** and **RIGHT HANDRAILS(17, 18)** face toward the trampoline. Insert the **LEFT** and **RIGHT HANDRAILS(17, 18)** into the **HANDRAIL SUPPORTS(19)** and lock in position with the **ADJUSTMENT KNOBS(21)**.

**NOTE:** There are Marks on the **LEFT** and **RIGHT HANDRAILS(17, 18)** to help to set the height of the handrail.

**STEP 8:** Stand on the trampoline to make all **LEGS(7)** and **HANDRAIL SUPPORTS(19)** set flat on the floor. Tighten all four **LOCKING KNOBS(22)** to lock the **HANDRAIL SUPPORTS(19)** in position.

**STEP 7:** Post the **USE INSTRUCTIONS SIGN(26)** in a highly visible and safe location. The **USE INSTRUCTIONS SIGN(26)** shall be placed such that it will be readily visible to the intended viewer.

**WARNING:** The **SAFETY PAD(6)** must be securely attached to the frame before using the trampoline. It must be properly positioned as shown in illustration 6.

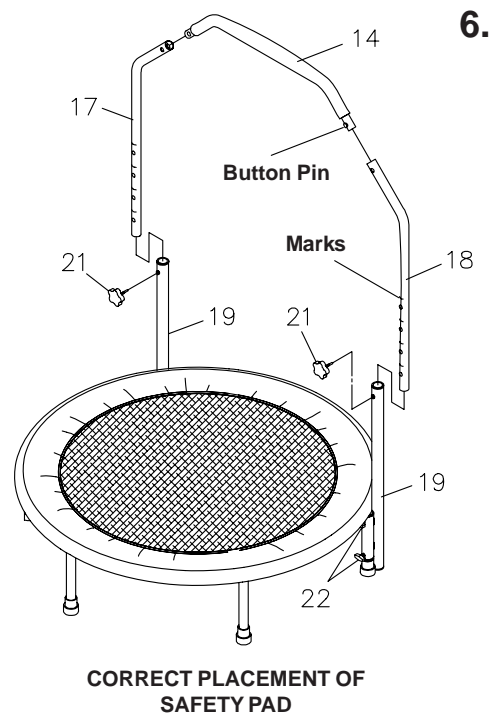

## INSTALLATION INSTRUCTIONS

1. Adequate overhead clearance is essential. A minimum of 24 feet from ground level is recommended for large outdoor trampolines. Provide clearance for ceilings, ceiling lights, ceiling fans, wires, tree limbs, and other possible hazards.
2. Lateral clearance is essential. Place the trampoline away from walls, structures, fences, play areas, furniture, and other exercise equipment. Maintain a clear space on all sides of the trampoline.
3. Place the trampoline on a level surface before use.
4. Use the trampoline in a well lighted area. Artificial illumination may be required for indoor or shady areas.
5. Secure the trampoline against unauthorized and unsupervised use.
6. Remove any obstructions from beneath the trampoline.
7. The owner and supervisors of the trampoline are responsible to make all users aware of practices specified in the use instructions.

## CARE AND MAINTENANCE

Inspect the **INTONE JOGGER** trampoline before each use and replace any worn, defective, or missing parts. The following conditions could represent potential hazards:

1. Missing, improperly positioned, or insecurely attached frame padding.
2. Punctures, frays, tears, or holes worn in the bed or frame padding.
3. Deterioration in the stitching or fabric of the bed or frame padding.
4. Ruptured springs.
5. A bent or broken frame.
6. A sagging bed.
7. Sharp protrusions on the frame or suspension system.

---

## USE INSTRUCTIONS

### **WARNING**

1. DO NOT attempt or allow somersaults. Landing on the head or neck can cause serious injury, paralysis, or death, even when landing in the middle of the bed.
2. Do not allow more than one person on the trampoline. Use by more than one person at the same time can result in serious injuries.
3. Use trampoline only with mature, knowledgeable supervision.
4. This trampoline is not recommended for children.
5. Inspect the trampoline before each use. Make sure the frame padding is correctly and securely positioned. Replace any worn, defective, or missing parts.
6. Climb on and off the trampoline. It is a dangerous practice to jump from the trampoline to the floor or ground when dismounting, or to jump onto the trampoline when mounting. Do not use the trampoline as a springboard to other objects.
7. Stop bounce by flexing knees as feet come in contact with the trampoline bed. Learn this skill before attempting others.
8. Learn fundamental bounces and body positions thoroughly before trying more advanced skills. A variety of trampoline activities can be carried out by performing the basic fundamentals in various series and combinations, performing one fundamental after another, with or without feet bounces between them.
9. Avoid bouncing too high. Stay low until bounce control and repeated landing in the center of the trampoline can be accomplished. Control is more important than height.
10. While keeping the head erect, focus eyes on the trampoline toward the perimeter. This will help control bounce.
11. Avoid bouncing when tired. Keep turns short.
12. Properly secure the trampoline when not in use. Protect it against unauthorized use. Protect it against use by children.
13. Keep objects away which could interfere with the performer. Maintain a clear area around the trampoline.
14. Do not use the trampoline while under the influence of alcohol or drugs.
15. For additional information concerning the trampoline equipment, contact the manufacturer.
16. For information concerning skill training, contact a certified trampoline instructor.
17. Bounce only when the surface of the bed is dry. Wind or air movement must be calm to gentle. The trampoline must not be used in gusty or severe winds.
18. Read all instructions before using the trampoline. Warnings and instructions for the care, maintenance, and use of the trampoline are included to promote safe, enjoyable use of this equipment.

---

## WORKOUT PROGRAM

**Stretching** Stretching while your muscles are warm after a proper warm-up and again after your strength or aerobic training session is very important. Muscles stretch more easily at these times because of their elevated temperature, which greatly reduces the risk of injury. Stretches should be held for 15 to 30 seconds. Do not bounce.

### Suggested Stretching Exercises

(Perform stretches slowly)

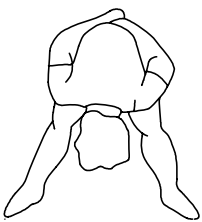

#### Lower Body Stretch

Place feet shoulder-width apart and lean forward. Keep this position for 30 seconds using the body as a natural weight to stretch the backs of the legs. **DO NOT BOUNCE!** When the pull on the back of the legs lessens, try a lower position gradually.



#### Floor Stretch

While sitting on the floor, open the legs as wide as possible. Stretch the upper body toward the knee on the right leg by using your arms to pull your chest to your thighs. Hold this stretch 10 to 30 seconds. **DO NOT BOUNCE!** Do this stretch 10 times. Repeat the stretch with the left leg.

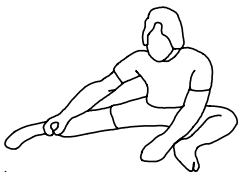
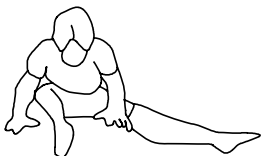

#### Bent Torso Pulls

While sitting on the floor, have legs apart one leg straight and one knee bent. Pull the chest down to touch the thigh on the leg that is bent and twist at the waist. Hold this position at least 10 seconds. Repeat 10 times on each side.



#### Bent Over Leg Stretch

Stand with feet shoulder-width apart and lean forward as illustrated. Using the arms, **gently** pull the upper body towards the right leg. Let the head hang down. **DO NOT BOUNCE!** Hold the position a minimum of 10 seconds. Repeat pulling the upper body to the left leg. Do this stretch several times slowly.

**Remember always to check with your physician before starting any exercise program.**

---

## WARM-UP AND COOL-DOWN

**Warm-up** The purpose of warming up is to prepare your body for exercise and to minimize injuries. Warm up for two to five minutes before strength-training or aerobic exercising. Perform activities that raise your heart rate and warm the working muscles. Activities may include brisk walking, jogging, jumping jacks, jump-rope, and running in place. Below are specific warm-up exercises for the trampoline workout.

**Cool-Down** The purpose of cooling down is to return the body to its normal, or near-normal, resting state at the end of each exercise session. A proper cool-down slowly lowers your heart rate and allows blood to return to the heart. Your cool-down should include the previously mentioned stretches and the same warm-up exercises listed below.

### Warm-up and Cool-down Exercises

(Do each movement 10 times)

#### Contact Bounce

Place your feet shoulder-width apart and bend at the knees. Place your hands on your waist. Start bouncing very gently without your feet leaving the mat. This movement is to get you comfortable with being on the mat.

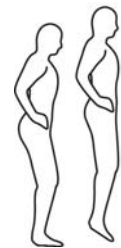

Contact Bounce

#### Foot Tap

While in the Contact Bounce position, shift your weight towards the right and tap your left foot out to the side. Bring your left foot back to shoulder width. Shift your weight to the left and tap your right foot out to the side. Repeat the movement back and forth.

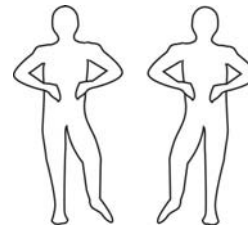

Foot Tap

#### Hamstring Curls

While bouncing, shift your weight to the right and bring your left foot up to your left buttock. Bring your left foot down and shift your weight to the left and bring your right foot up to your right buttock. Repeat the movement back and forth.

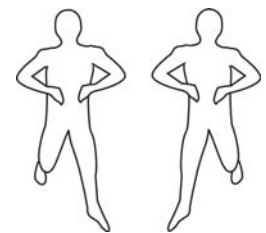

Hamstring Curls

#### Side To Side

In this movement, place both feet together and bounce from one side of the mat to the other side of the mat. Repeat the movement back and forth.

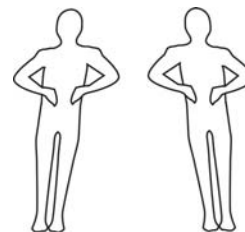

Side To Side

#### Jog in Place

While standing in the center of the mat, jog in place as you would on the ground.

#### Jog Bounce

While jogging in place, bounce twice on one leg before switching to the other leg.

---

## BASIC WORKOUT

### Basic Workout Exercises

(Do each movement 10 times)

#### Contact Bounce, Big Bounce

Place your feet shoulder-width apart and bend at the knees. Place your hands on your waist. Start bouncing very gently without your feet leaving the mat. On your second bounce, bounce high enough that your feet leave the mat; only bounce as high as you feel comfortable bouncing. Continue to alternate your bounces back and forth. A variation can be done by raising your forearms as if you are doing biceps curls.

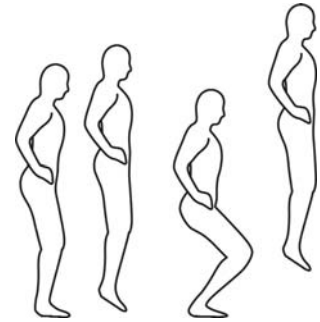

#### Knee Raises

While in the Contact Bounce position, alternately raise your right and left knees to just above waist height. Repeat the movement back and forth. You can add your own variations to this movement such as raising your arms out to the sides or to the front.

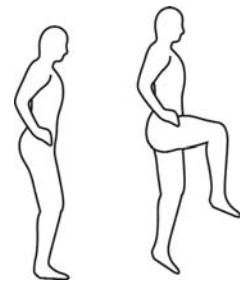

#### Jumping Jacks

With your feet together in the center of the mat, simultaneously bounce and land with your feet shoulder width apart. At the same, raise your arms out to the sides and overhead. Then, bounce and land with your feet back together and your arms resting at your sides. Repeat the movement.

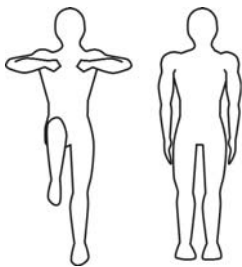
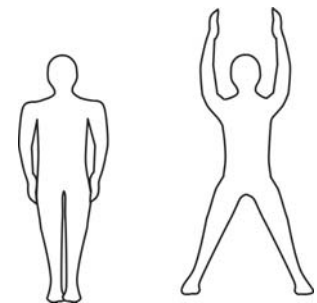

#### Upright Row

While in the Contact Bounce position, alternately raise your knees to just above waist height. At the same time, perform an upright row with your arms to chin height each time you raise a knee. Repeat the movement.

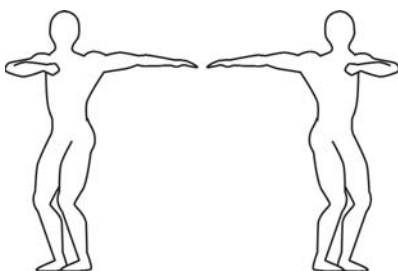

#### Twist Bounce

With your feet together in the center of the mat bounce and twist your lower body to the right, simultaneously twisting your upper body to the left. Then bounce and twist your lower body to the left, simultaneously twisting your upper body to the right. Repeat the movement.

---

## **BASIC WORKOUT (continued)**

### **Basic Workout Program**

#### **Jogger Warm-Up**

*Do each exercise 10 times*

1. Contact Bounce
2. Foot Tap
3. Hamstring Curls
4. Side to Side
5. Contact Bounce
6. Jog in Place
7. Jog Bounce
8. Jog in Place
9. Contact Bounce

#### **Jogger Cool Down**

*Do each exercise 10 times*

1. Contact Bounce
2. Jog in Place
3. Jog Bounce
4. Jog in Place
5. Contact Bounce
6. Side to Side
7. Hamstring Curls
8. Foot Tap
9. Contact Bounce

#### **Basic Workout**

*Do each exercise 10 times*

1. Contact Bounce, Big Bounce  
(Hands on waist)
2. Contact Bounce, Big Bounce  
(Hands, Triceps/biceps movement)
3. Jog in Place
4. Knee Raises (Hands and Shoulder  
movement)
5. Jumping Jacks
6. Upright Row
7. Jog in Place
8. Front / Back jumps (Lateral and Forward  
shoulder raise)
9. Twist Bounce
10. Knee Raises (Hands on waist)
11. Jog in Place

Licensed Under U.S. Patent 6,237,169B1  
Other Patents Applied and Are Pending

## WARRANTY

Stamina Products, Inc. warrants that this product will be free from defects in materials and workmanship under normal use, service and proper operation for a period of 90 days on the parts and 5 years on the frame from the date of the original purchase from an authorized retailer. **THIS WARRANTY SHALL NOT APPLY TO ANY PRODUCT WHICH HAS BEEN SUBJECT TO COMMERCIAL USE, ABUSE, MISUSE, ALTERATION OF ANY TYPE OR CAUSE OR TO ANY DEFECT OR DAMAGE CAUSED BY REPAIR, REPLACEMENT, SUBSTITUTION OR USE WITH PARTS OTHER THAN PARTS PROVIDED BY STAMINA PRODUCTS, INC.** Commercial use includes use of the product in athletic clubs, health clubs, spas, gymnasiums, exercise facilities, and other public or semipublic facilities whether or not the product's use is in furtherance of a profit making enterprise, and all other use which is not for personal, family, or household purposes.

To implement this limited warranty, send a written notice stating your name, date, and place of purchase and a brief description of the defect along with your receipt to **Stamina Products, Inc. P.O. Box 1071, Springfield Missouri, USA, 65801-1071** or call us at **1 (800) 375-7520**. If the defect is covered under this limited warranty, you will be requested to return the product or part to us for free repair or replacement at our option. **NO ACTION FOR BREACH OF THIS LIMITED WARRANTY MAY BE COMMENCED MORE THAN ONE (1) YEAR AFTER THE DATE THE ALLEGED BREACH WAS OR SHOULD HAVE BEEN DISCOVERED. NO ACTION FOR BREACH OF ANY IMPLIED WARRANTY MAY BE COMMENCED MORE THAN ONE (1) YEAR AFTER DELIVERY OF THE PRODUCT TO THE PURCHASER.** This limited warranty is not transferable. **IF ANY PART OF THE PRODUCT IS NOT IN COMPLIANCE WITH THIS LIMITED WARRANTY OR ANY IMPLIED WARRANTY, THE REMEDY OF REPAIR OR REPLACEMENT IS THE EXCLUSIVE REMEDY AVAILABLE TO YOU.** In the event that the purchaser makes any claim under this limited warranty or any implied warranty, the Warrantor reserves the right to require the product to be returned for inspection, at the purchaser's expense, to the Warrantor's premises in Springfield, Missouri. Return of the enclosed warranty registration card is not required for warranty coverage, but is merely a way of establishing the date and place of purchase.

Stamina Products, Inc. **SHALL NOT BE LIABLE FOR THE LOSS OF USE OF ANY PRODUCT, LOSS OF TIME, INCONVENIENCE, COMMERCIAL LOSS OR ANY OTHER INDIRECT, CONSEQUENTIAL, SPECIAL OR INCIDENTAL DAMAGES DUE TO BREACH OF THE ABOVE WARRANTY OR ANY IMPLIED WARRANTY.**

This limited warranty is the only written or express warranty given by Stamina Products, Inc. This warranty gives you specific legal rights, and you may also have other legal rights which vary from state to state. **ANY OTHER RIGHT WHICH YOU MAY HAVE, INCLUDING ANY IMPLIED WARRANTY OR MERCHANTABILITY OR FITNESS FOR A PARTICULAR PURPOSE, IS LIMITED IN DURATION TO THE DURATION OF THIS WARRANTY.**

The laws in some jurisdictions restrict the rights of manufacturers and distributors of consumer goods to disclaim or limit implied warranties and consequential and incidental damages with respect thereto. If any such law is found to be applicable, the foregoing disclaimers and limitations of and on implied warranties and consequential and incidental damages with respect thereto shall be disregarded and shall be deemed not to have been made to the extent necessary to comply with such legal restriction.

---

## NOTES

