

rejuvasun™
332 user
manual

27938-01A

48 MONTH "GOLD MEDAL" WARRANTY

Your ETS Distributor (including ETS, LLC if purchased directly), through a manufacturer's warranty, warrants your tanning unit to be free of structural defects in material and workmanship, under normal use, for its lifetime. Your ETS Distributor will, at its discretion, repair any structural defect which materially affects the performance of the tanning unit, or replace the tanning unit.

For forty-eight (48) months following the purchase date of your tanning unit, your ETS Distributor will provide replacements for parts that prove to be defective in material or workmanship, with the following exceptions: gas springs, ballasts, electronic lamp starters and the Rejuvasun™ panel are warranted against manufacturer's defects for a period of one (1) year; "glow tube" lamp starters and cracked or broken endcaps are warranted against manufacturer's defects for a period of ninety (90) days; fluorescent lamps are warranted against manufacturer's defects for a period of thirty (30) days; acrylics are warranted against manufacturer's defects for a period of one (1) year (prorated) following the purchase date of your tanning unit. Shipping charges will be covered during the first ninety (90) days following the purchase date.

Your ETS Distributor (including ETS, LLC if purchased directly), also extends to you a two (2) year parts warranty on all T-Max® remote system components. External voltage transformers (buck-boosters) are covered by a one (1) year parts and labor warranty, provided you send back the defective transformer.

Labor costs associated with repair or replacement work covered by this warranty will be reimbursed for repair or replacement work required to be performed for a period of ninety (90) days following the shipping date of your tanning unit. Normal wear and tear, damage from misuse or abuse, damage incurred in transit or damages resulting from unauthorized repairs or modifications are not covered by this warranty. Warranty coverage does not include cosmetic abnormalities such as scratches, nicks, dents, or other cosmetic changes that do not materially interfere with the function of the tanning unit.

THIS 48 MONTH "GOLD MEDAL" WARRANTY IS EXPRESSLY MADE IN LIEU OF ANY OTHER WARRANTIES, EXPRESS OR IMPLIED, INCLUDING ANY IMPLIED WARRANTIES OF MERCHANTABILITY AND FITNESS FOR A PARTICULAR PURPOSE, WHICH ARE HEREBY DISCLAIMED. No one has the authority to change or modify this 48 Month "Gold Medal" Warranty in any respect. To obtain service under this 48 Month "Gold Medal" Warranty, contact your authorized ETS Distributor (or ETS, LLC if purchased directly). Proof of purchase, including serial number, is required.

IN NO EVENT SHALL YOUR DISTRIBUTOR OR THE MANUFACTURER BE LIABLE AT LAW OR IN EQUITY FOR ANY LOSS, LIABILITY, DAMAGE OR EXPENSE IN AN AMOUNT IN EXCESS OF THE PURCHASE PRICE RECEIVED, OR FOR LOSS OF USE OR PROFITS, LOSS OF TIME, INCONVENIENCE, RENTAL OR SUBSTITUTE PRODUCTS, LOSS OF BUSINESS, LOSS OF INCOME, OR ANY OTHER INCIDENTAL INDIRECT, SPECIAL OR CONSEQUENTIAL DAMAGES. Some states do not allow the exclusion or limitation of incidental or consequential damages, and the above limitation or exclusion will not apply to residents of some states. This 48 Month "Gold Medal" Warranty gives you specific, legal rights and you may have other rights which may vary from state to state.

All warranty service must be performed by an authorized service person using only ETS authorized replacement parts. Use of non-authorized parts may void your warranty. All labor charges must be authorized by your ETS Distributor prior to the start of repairs and must not exceed the established rates and time allotment policies established by your ETS Distributor. If your tanning unit must be returned for service within thirty (30) days from the purchase date, freight charges will be paid for by your ETS Distributor, after which all freight charges shall be at your expense. Contact your ETS Distributor for the authorized Service Center nearest you. This warranty is serial number specific and only applies to tanning units purchased through an authorized ETS Distributor. This warranty is extended to the individual or legal entity whose name appears on the original sales document and may not be transferred to any other individual or legal entity. This warranty is void if the tanning unit is modified in any manner from its original design.

To obtain warranty service, contact your place of purchase. Proof of purchase, including serial number, is required for verification. Contact ETS, LLC only if you purchased your equipment directly.

ETS, LLC 7445 Company Drive, Indianapolis, IN 46237-9296
1-800-449-3605 In Canada call 1-800-661-6292 or 519-421-1212



elcome

Congratulations on your purchase of this technologically advanced sun tanning unit. Not only is this unit designed and manufactured for years of dependable service, the new Rejuvasun™ unit opens up a new revenue channel for your salon.

Please read all the instructions in this booklet before installing and using the unit. Always be sure to observe all safety precautions.

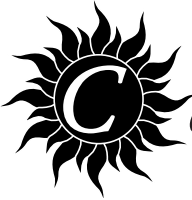

ontents

- Safety Informationiii
- Installation1
 - Unpacking and Inspection1
 - Pre-Installation Planning2
 - Hardware Inventory3
 - Assembly Procedures4
 - Electrical Connections10
 - Final Assembly11
 - Remote Connections12
- Operation17
 - Before You Tan17
 - Exposure Times17
 - Using Your Sunbed18
- Care and Maintenance20
 - Cleaning After Use20
 - Thorough Periodic Cleaning20
 - Mechanical Inspection20
 - Lamp and Acrylic Replacement21
- Troubleshooting24



LABELING NOTICE: Labels are affixed on all systems to inform the user of possible dangers. Regulations are stated in 21 CFR, Section 1040.20, and require that all products manufactured after September 8, 1986 which use sunlamps must display the following:

DANGER Ultraviolet radiation. Follow instructions. Avoid overexposure. As with natural sunlight, overexposure can cause eye and skin injury and allergic reactions. Repeated exposure may cause premature aging of the skin and skin cancer. **WEAR PROTECTIVE EYEWEAR; FAILURE TO MAY RESULT IN SEVERE BURNS OR LONGTERM INJURY TO THE EYES.** Medications or cosmetics may increase your sensitivity to the ultraviolet radiation. Consult physician before using sunlamp if you are using medications or have a history of skin problems or believe yourself especially sensitive to sunlight. If you do not tan in the sun, you are unlikely to tan from the use of this product. Children, the elderly, or fair skinned people who always burn easily and either never tan or tan minimally should not use this equipment.

To use, lie down under canopy and pull down as far as adjustment will allow. Minimum use distance from face tanner is 4 inches (10.2 centimeters), otherwise overexposure may occur. Minimum use distance elsewhere is touching the clear plastic panels. Do not use without clear plastic panels in place. Untanned persons should not tan on consecutive days during their first week of tanning. Never tan more than once a day. Tanning normally appears after the first few sessions and maximizes after approximately four weeks. Tan once or twice per week thereafter to maintain appearance. Persons already having a base tan may begin at advanced levels corresponding to the extent of their base tan.

RECOMMENDED EXPOSURE TIMES IN MINUTES		MAXIMUM EXPOSURE TIME IS 20 MINUTES				
Skin Type:		Level 1/Week 1 1st-3rd Sessions	Level 2	Level 3	Level 4	Level 5
I Sensitive Skin (Burns easily and severely and does not tan.)		NOT RECOMMENDED FOR TANNING				
II Light	(Burns easily and severely and tans minimally.)	4	8	12	16	20
III Normal	(Burns moderately and tans average.)	6	10	15	20	20
IV Dark	(Burns minimally, tans easily and above average.)	8	12	16	20	20

New lamps emit approximately 10% more ultraviolet radiation during the first 50 hours of operation. Recommended tanning times should therefore be reduced by approximately 10% during that period.

WARNING: • Read the instructions booklet before using this sunlamp product. • All persons in the room should wear protective eyewear when lamps are on. Required eyewear: Ultra SunGlobes®, *special-eyez*, or other dark-tinted eyewear that meet 21 CFR 1040.20 guidelines. Other types of eyewear may not provide adequate protection. Failure to use protective eyewear may result in severe burns or other eye injury. If discomfort develops, discontinue use and consult a physician.

ONLY THE FOLLOWING LAMPS HAVE BEEN CERTIFIED FOR USE IN THIS EQUIPMENT:

Velocity® Wolff® Model VEL71-T12 / 100W PREHEAT-BIPIN (Bench lamps)

Velocity® PLUS Wolff® Model VLP71-T12-100W Bi-Pin (Canopy lamps)

Heraeus E400 HPT -or- Philips Model HPA 400/30s -or- CosmoTech Model 23045 (SolarMax™ IFT facial unit)

DISCONNECT POWER BEFORE ATTEMPTING TO CLEAN, RELAMP, OR ENGAGE IN THE MAINTENANCE OF THIS PRODUCT.

THIS EQUIPMENT MUST BE EARTH GROUNDED.

This product is in conformity with performance standards for sun lamp products under 21 CFR PART 1040.20 and ANSI/UL Standard 482. Certified to CAN/CSA Standard C22.2 NO. 224.





DANGER

Rayonnement ultraviolet. Veuillez suivre les instructions. Évitez une exposition excessive. Tout comme pour les rayons du soleil, une exposition excessive peut causer des blessures aux yeux et à la peau et provoquer des réactions allergiques. Une exposition répétée peut causer le vieillissement prématuré de la peau et provoquer le cancer de la peau. **PORTEZ DES LUNETTES PROTECTRICES: LE NON-RESPECT DE CETTE CONSIGNE DE SÉCURITÉ PEUT ENTRAÎNER DE GRAVES BRÛLURES OU DES LÉSIONS OCULAIRES À LONG TERME.** Les médicaments ou les produits cosmétiques peuvent augmenter votre sensibilité au rayonnement ultraviolet. Consultez un médecin avant d'utiliser la lampe solaire si vous prenez des médicaments, si vous souffrez d'une maladie cutanée ou si vous croyez être particulièrement sensible aux rayons du soleil. Si vous ne bronzez pas au soleil, il est peu probable que vous bronzez sous une lampe solaire. Les enfants, les personnes âgées et les personnes qui ont une peau claire qui brûle facilement, ne bronze jamais ou alors très peu, ne devraient pas utiliser cette lampe.

Étendez-vous sous la partie supérieure, puis abaissez celle-ci aussi bas que possible. La distance minimale d'usage de l'appareil de bronzage pour le visage est de 4 pouces (10.2 centimètres), afin d'éviter une exposition excessive. Les autres parties du corps peuvent toucher les panneaux de plastique transparents. N'utilisez pas la lampe sans les panneaux de plastique transparents. La première semaine de bronzage, les personnes qui n'ont pas un hâle initial ne doivent pas se faire bronzer tous les jours. Ne vous faites jamais bronzer plus d'une fois par jour. Le bronzage commence normalement à apparaître après les premières séances : il atteint son apogée au bout d'environ quatre semaines. Les personnes qui ont déjà un teint hâlé peuvent commencer à des niveaux plus élevés, selon l'importance de leur hâle initial.

TEMPS D'EXPOSITION RECOMMANDÉ EN MINUTES LE TEMPS D'EXPOSITION MAXIMAL EST DE 20 MINUTES

Type de peau:	Élevé 1/Semaine 1 1 ^{ère} -3 ^e	Élevé 2	Élevé 3	Élevé 4	Élevé 5
I Peau sensible (brûle facilement et ne bronze pas)	NON RECOMMANDÉ				
II Peau claire (brûle facilement et bronze très peu)	4	8	12	16	20
III Peau normale (brûle et bronze de façon modérée)	6	10	15	20	20
IV Peau foncée (brûle très peu, bronze plus facilement que la moyenne)	8	12	16	20	20

Les lampes neuves émettent approximativement 10 % de plus de rayons ultraviolets au cours des 50 premières heures de fonctionnement. Le temps de bronzage doit donc être réduit d'environ 10 % pendant cette période.

AVERTISSEMENT : • Lisez le livret d'instructions avant d'utiliser cette lampe solaire. • Les autres personnes présentes dans la pièce doivent aussi porter des lunettes protectrices lorsque les lampes sont allumées. Coquilles de protection pour les yeux recommandées: Ultra SunGlobes®, *special-eyes*, ou l'équivalent, tel que le stipule le document 21 CFR 1040.20. Les autres types de lunettes protectrices peuvent ne pas assurer une protection adéquate. Utilisez sans lunettes protectrices, ce produit peut causer des brûlures ou lésions oculaires graves. Si vous souffrez d'un malaise, arrêtez l'utilisation et consultez un médecin.

SEULES LES LAMPES SUIVANTES ONT ÉTÉ HOMOLOGUÉES POUR CET ÉQUIPEMENT :

Velocity® Wolff® Modèle VEL71-T12 / 100W PREHEAT-BIPIN (banc seulement)

Velocity® PLUS Wolff® Modèle VLP71-T12-100W Bi-Pin (partie supérieure seulement)

Heraeus E400 HPT -ou- Philips Modèle HPA 400/30s -ou- CosmoTech Modèle 23045 (unité faciale)

Débrancher l'alimentation électrique avant de nettoyer l'appareil , d'en faire l'entretien ou de changer les lampes.



Cet équipement doit être mis à la terre.

Ce produit est conforme aux normes de rendement pour les lampes solaires dans le documents 21 CFR, partie 1040.20 , ANSI/UL 482 , CAN/CSA C22.2 N° 224.

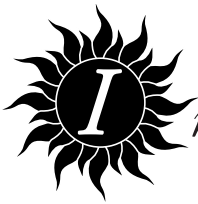

Unpacking and Inspection

Your sunbed comes in two cardboard cartons, one for the canopy and one for the bench and ballast tray. Open the cartons and remove the sunbed parts as follows.

The boxes dismantle to allow easy removal of the units. Remove the box tops and pull the sides out. The bench and canopy are each wrapped in plastic. Remove the plastic and, with a helper or two, grasp the canopy and pull it from the carton bottom **without using the plastic endcaps to lift the unit**. Do the same for the bench. Do not attempt to lift either unit with the plastic still on as it may slip. The ballast drawer is secured to the carton bottom with brackets. Remove these brackets from the ballast drawer with a Phillips screwdriver.

Note! The cartons are reusable. You may wish to save them for future use.

CAUTION

DO NOT lift the canopy using the plastic endcaps. They are not designed to hold the weight of the unit and may break, causing damage to the unit and possible injury.

After unpacking the unit, check to make sure you have received the following:

- Canopy unit
- Bench unit
- Ballast drawer
- Body fan kit
- Pair of gas springs
- (2) endcaps (one with slots for the body fan bracket)
- Front access panel
- Bag containing necessary assembly hardware, safety goggles, and pillow

Inspect these items, including the canopy and bench, and make sure they are free from any visible damage. Report the extent of any damage to the transportation company.

Record the serial number of the unit in the area provided at the back of this manual. This information will be required whenever you call customer service.



Pre-Installation Planning

Before you begin to assemble your sunbed, you should observe the following considerations.

	⚠ WARNING
	Shock hazard. Disconnect power before servicing.

⚠ CAUTION
Use of a voltage source above 230V AC may prevent proper operation of the sunbed and could cause damage and void the warranty.

- The **Rejuvasun™ 332** requires a dedicated circuit capable of providing **30 Amp** service at **220VAC**. This unit must be hardwired directly to a junction box on a dedicated circuit. We recommend connection by a professional electrician.
- **IMPORTANT!** Voltage must be below 230V AC or may require a Buck Booster.
- Some portions of the carton may be used for assembly. Do not discard cartons until assembly is complete.
- You will need a #2 Phillips screwdriver to assemble this tanning bed.

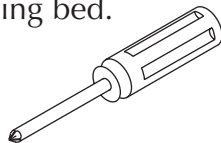

⚠ CAUTION
Air from the room is used to cool the sunbed. Maximum ambient room temperature should be 80°F. Place your sunbed no closer than 6" from any wall. Make sure nothing obstructs the airflow into or out of the fan openings. A poorly ventilated room may cause the unit to become hot and cause discomfort to the user.

⚠ CAUTION
Proper assembly of your sunbed requires three people. Plan to have a couple of helpers assist you.



Hardware Inventory

Open the hardware bag. Remove the hardware. In addition to a phone type (RJ-11) cable and pillow, make sure you have the following items.

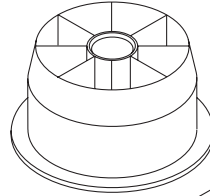

Nylon Floating Bearing
Quantity 4

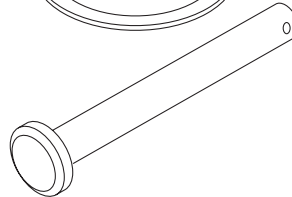

Hinge Pin,
5/16" x 2 1/32"
Quantity 2



Hinge Pin Locking Clip
Quantity 2

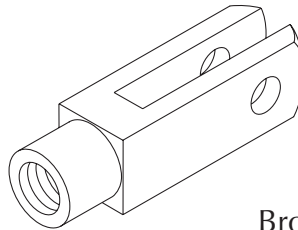

Clevis Fork,
M10 Long
Quantity 2

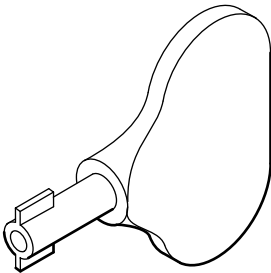

Access Panel Key
Quantity 1



Bronze Bushing, 10mm
Quantity 2

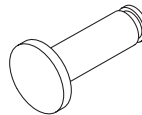

Clevis Pin, 10mm
Quantity 2



Retaining Ring
Quantity 2

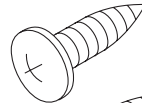

Phillips Screw, #10 x 1/2"
Quantity 8

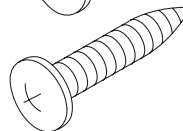

Phillips Screw, #10 x 1"
Quantity 8

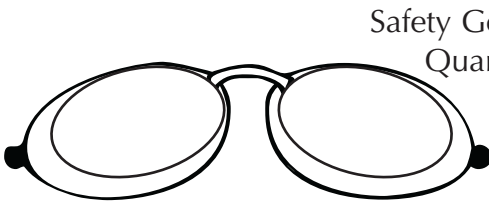

Safety Goggles
Quantity 1

! WARNING

Always wear protective eyewear when unit is on. Failure to may result in severe burns or longterm injury to the eyes.



Assembly Procedures

Stand Assembly

1. Place the bench unit approximately where it will be when assembled. Leave some room behind it to work.
2. Slide the ballast drawer under the bench, as shown, with the cables toward the back.

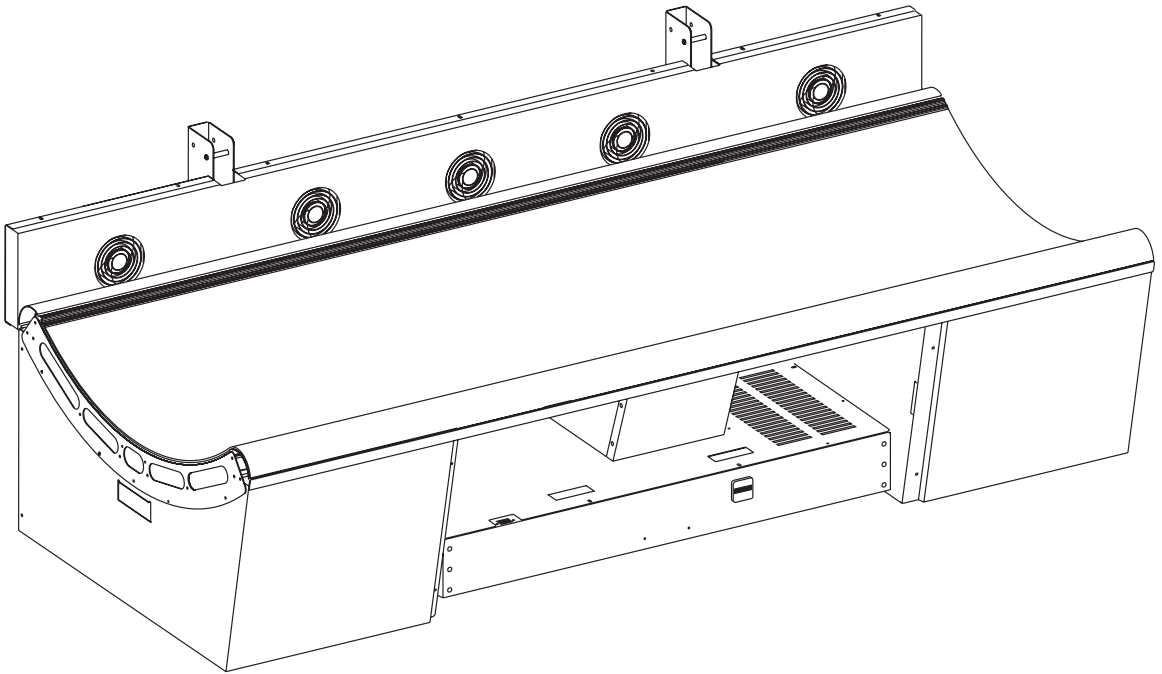



Install Canopy

1. Lay something across the bench, such as some cardboard or a blanket, to protect the units and place the canopy on the bench with the canopy hinge arms toward the back. Once again, do not use the canopy plastic endcaps to lift the unit.

! CAUTION

DO NOT lift the canopy using the plastic endcaps. They are not designed to hold the weight of the unit and may break, causing damage to the unit and possible injury.

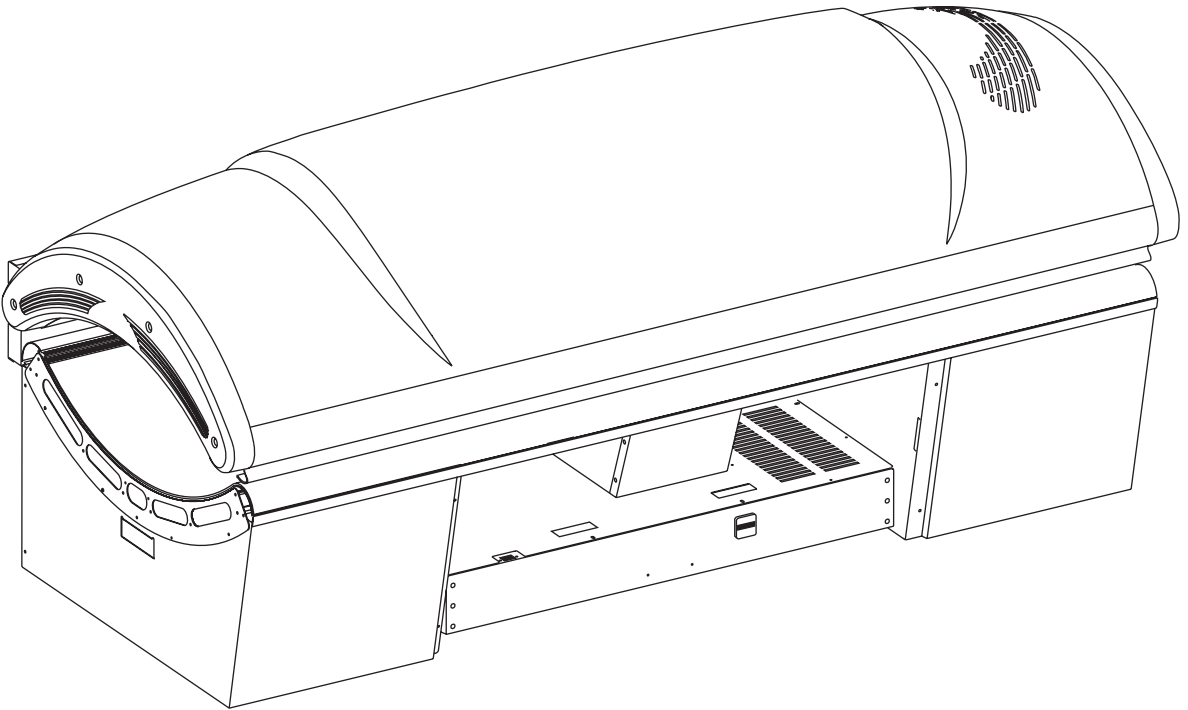



2. Insert the Nylon Floating Bearings into the canopy hinge arms and carefully lower the hinge arms into the bench uprights.
3. Secure the arms in place with the Hinge Pins and Hinge Pin Locking Clips.

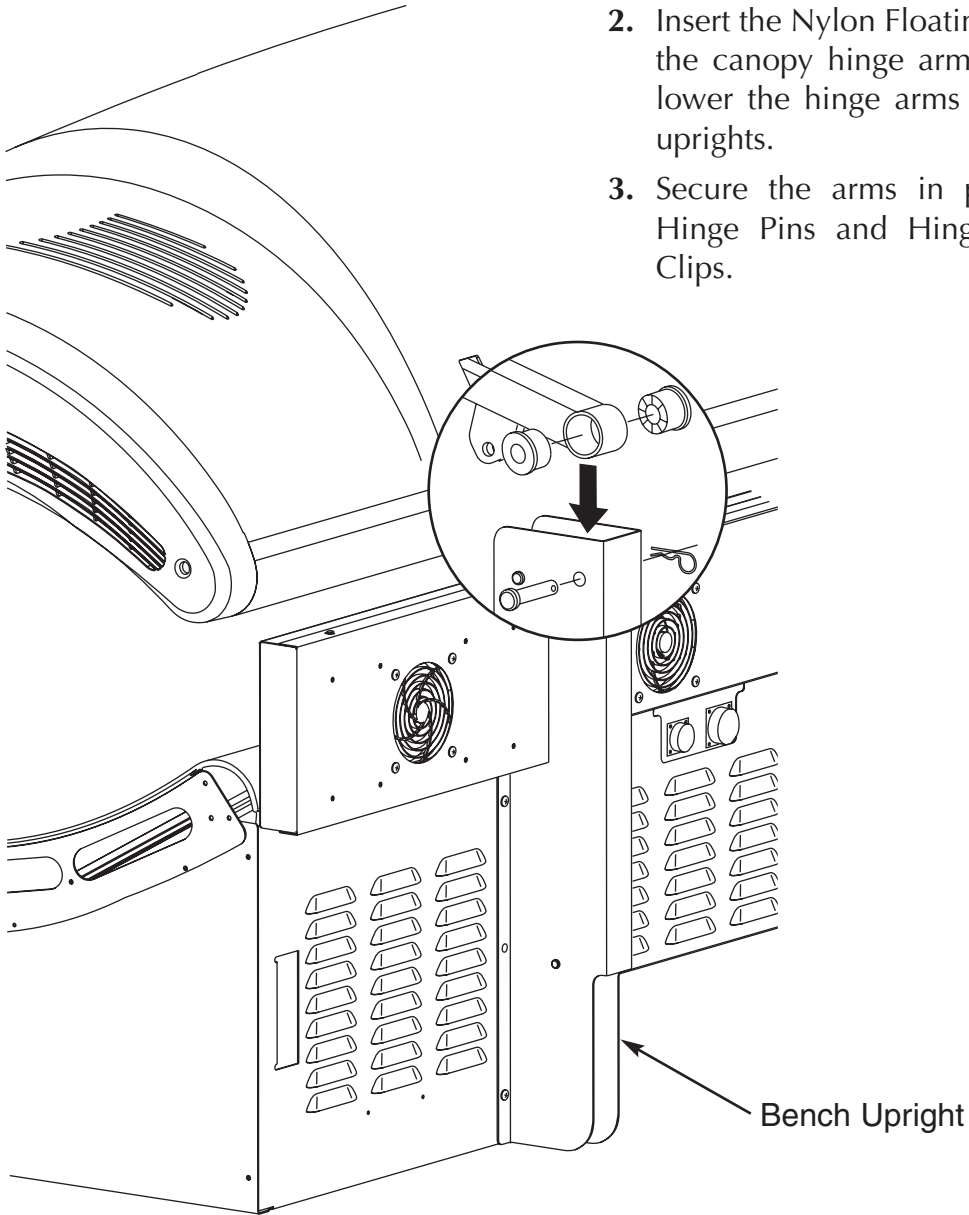



Install Gas Springs

1. Screw the upper Clevis Forks onto the Gas Springs, piston end up as shown.
2. Have a helper hold the canopy in its fully open position.
3. The lower clevis forks are already installed. Make sure the threaded hole faces up, slide the Gas Springs down into the bench uprights and twist the Gas Springs into the lower clevis forks. Turn the Gas Springs until they are snug.

Do not lower the canopy yet!

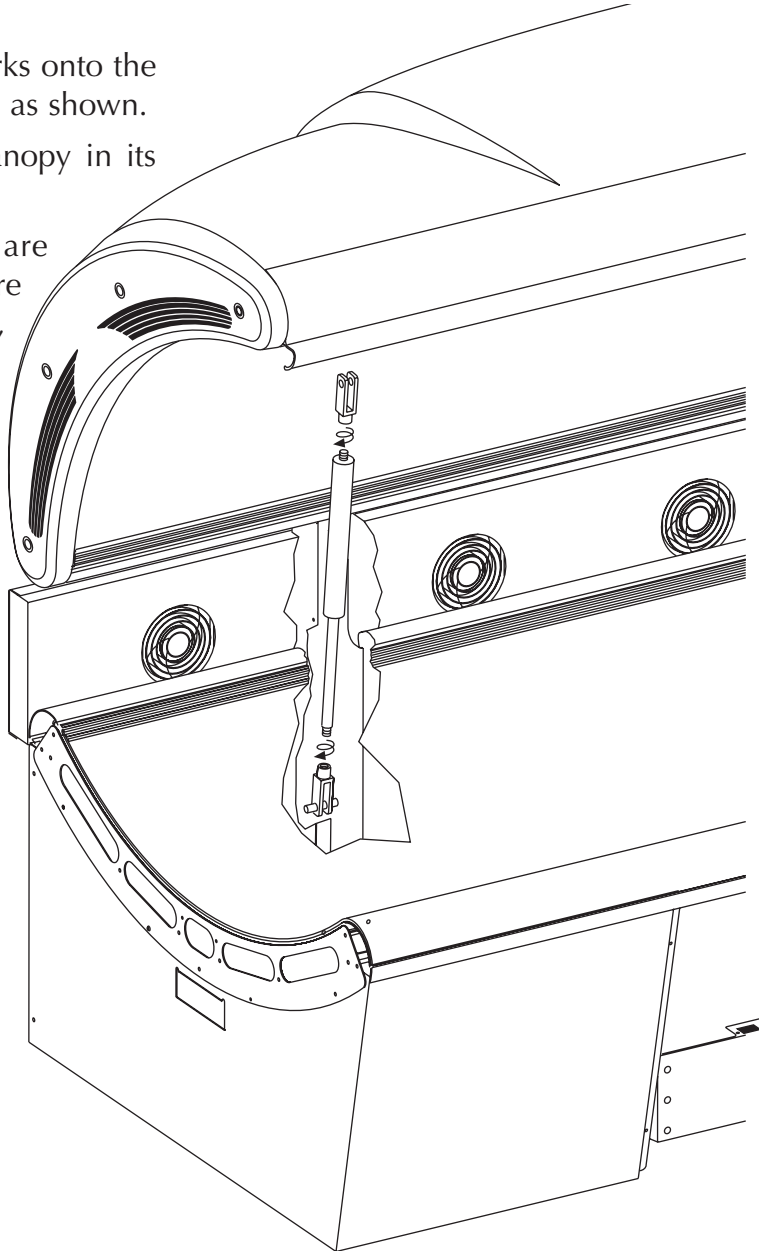



Attach Gas Springs

1. With the canopy still raised, slip the Bronze Bushings into the hole in the clevis brackets on the underside of the canopy mounting arms.
2. Line up both Clevis Forks and carefully lower the canopy to engage the Clevis Forks. Pay special attention when lowering the canopy that the clevis forks do not damage the bronze bushings. Bronze is excellent for smooth pivoting applications such as this, but tends to be soft compared to the steel clevis fork.
3. Lock the Clevis Forks in place with the Clevis Pins
4. Secure the Clevis Pins with the Retaining Rings.

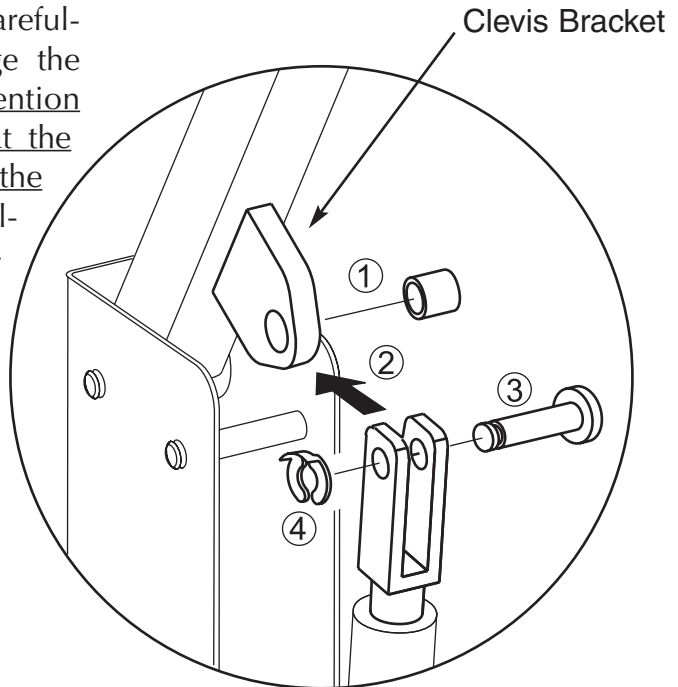

NOTE: When this assembly is complete, lift and lower the canopy a few times to lubricate the gas springs for optimum performance.



Install Endcaps

NOTE: This unit comes with a foot end body fan. Instructions for installing the fan are included with the body fan kit. Follow those instructions to install the body fan.

Put the head end endcap (the one without slots on top) in place and secure with two #10 x 1/2" screws in the two middle holes. Use two #10 x 1" screws in the two outer holes.

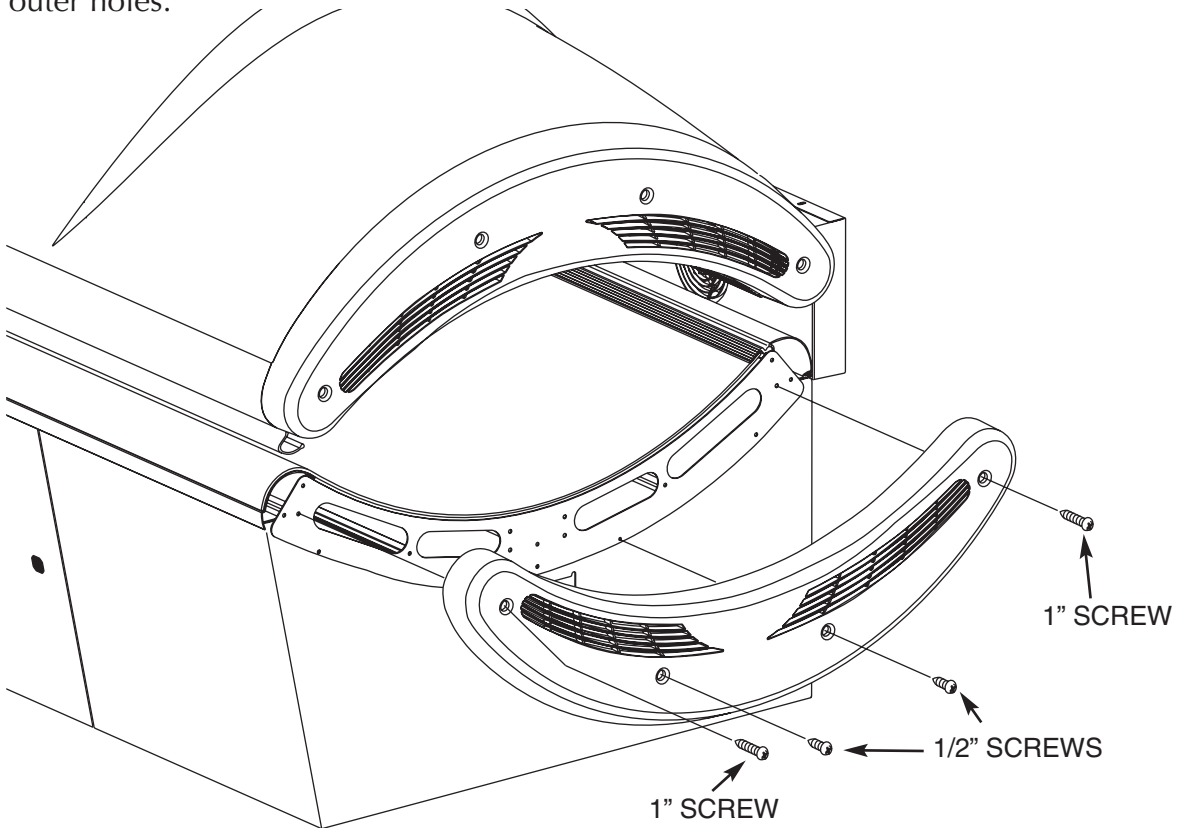



Electrical Connections

At the rear of the sunbed, connect the two canopy power cords and two bench power cords from the ballast tray to their respective power receptacles. Simply match the plug to the receptacle, push on firmly and secure by twisting the threaded locking ring. Connect the RJ-11 (phone type) cable between the canopy and rear jack on the ballast drawer. The three jacks on the front of the drawer are for remote connections. Connect main power cord as described in Pre-Installation Planning.

Helpful Hint: Line up the plug with the proper receptacle and push in. Apply pressure to the plug and twist the locking ring counter-clockwise until you feel the plug click into place. Then turn the locking ring clockwise to secure it. The ring will click when fully engaged.

PIN CONFIGURATIONS MAY VARY FROM SHOWN

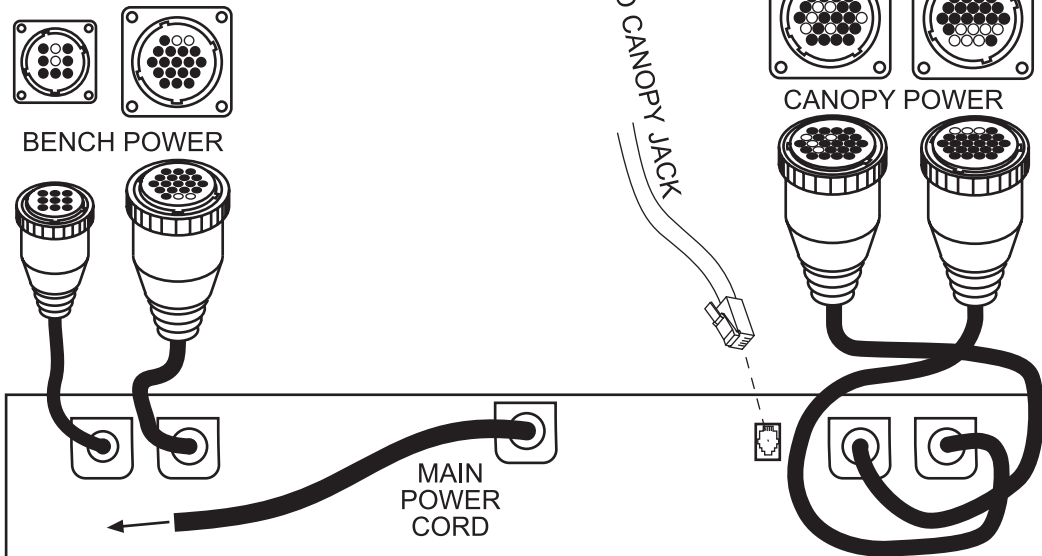



Final Assembly

Make sure the air filter is in place on top of the ballast drawer. It simply sits on the drawer, over the air slots, and is held in place by airflow when the unit is running. The arrow on the filter should point down.

Put the Front Access Panel in place and lock with the Access Panel Key.

Note: You may have a few extra screws left over.

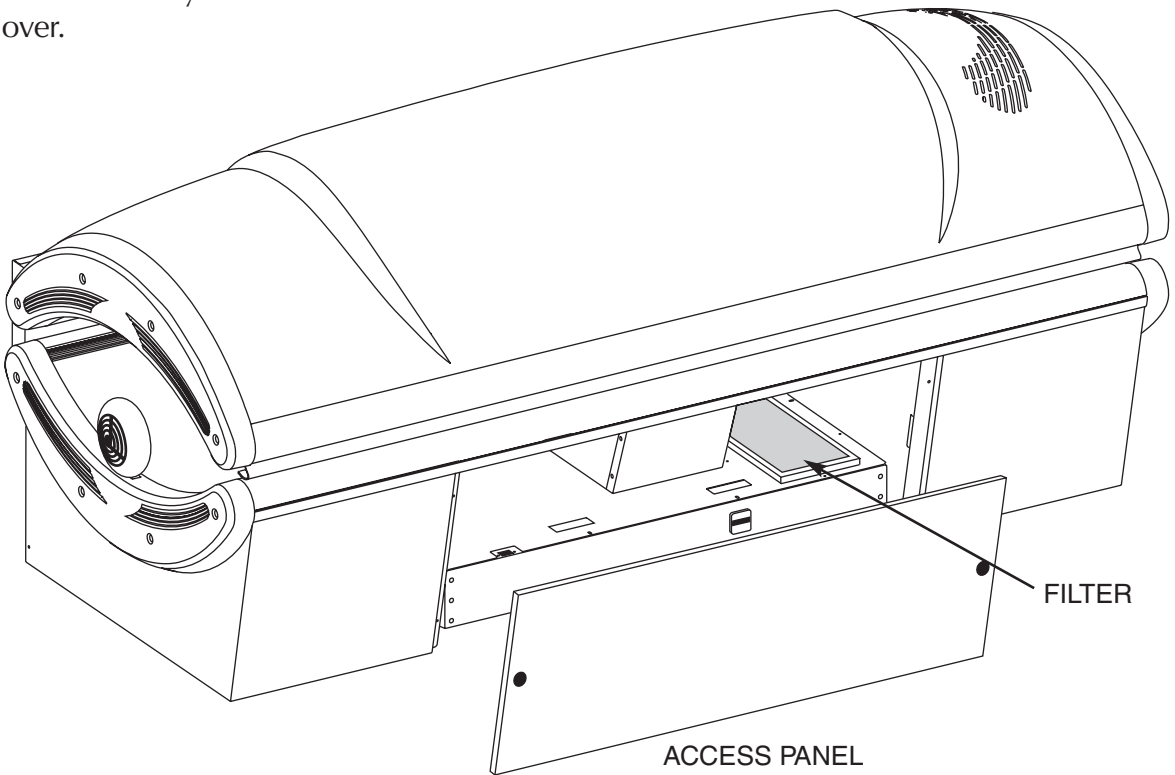



Remote Connections

Your sunbed incorporates advanced circuitry allowing it to connect and communicate with most remote control systems. If a remote system is to be used, first determine whether the remote system is a T-Max® System or a standard remote system operating with a control relay. The following pages outline many different remote connection scenarios. Find the scenario that best fits your application.

Three remote ports are located on top of the ballast drawer at the front, two RJ-22 (4-wire) ports and one RJ-11 (6-wire) port. A Remote Control Bypass plug is already installed in one of the RJ-22 remote control ports. Your sunbed will not operate without the Remote Control Bypass plug or a remote system connected.

ATTENTION: Although the Remote Control Bypass plug provided with your sunbed will work wherever a T-Max® terminator is called for in the series, the T-Max® terminator will not work as a bypass plug. Normally, a bypass plug is needed only when your sunbed is operated without a remote system connected.

You will notice some wire clamps along the side of the fan housing under the bench. These are for the remote cables to keep them out from under the ballast drawer when rolling the drawer in and out of the unit. Route the remote cables as shown below, leaving some slack for the drawer to roll out.

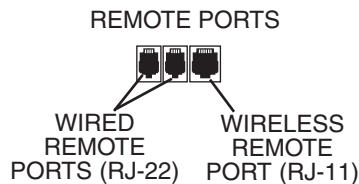
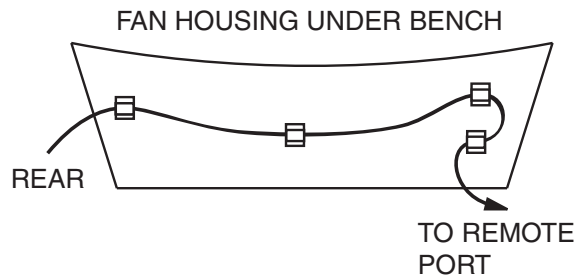



Remote Connections

Your sunbed incorporates advanced circuitry allowing it to connect and communicate with most remote control systems. If a remote system is to be used, first determine whether the remote system is a T-Max® Manager Pro System or a standard remote system operating with a control relay. Follow the appropriate instructions for your system type.

CAUTION

The remote connection is not designed to supply or accept high voltage, nor can it provide power to an external timer. The sunbed's remote interface circuitry operates on 5 volts, attempting to connect it to any higher voltages will damage the sunbed as well as void your warranty.

T-Max® Manager Series

The T-Max® Manager series offers the ultimate in sunbed control, while allowing the tanner easy straightforward operation. Your sunbed is configured to directly connect to this system, including the new wireless remote system. The circuitry inside your sunbed eliminates the need for the T-Max 1A or 3A when connecting to the T-Max Manager series. Your sunbed supports the auto addressing feature of the Manager and the following parameters: 5, 6, 7, 8, 9, 10, 15 and 23. See your T-Max® manual for descriptions of these parameters and how they function.

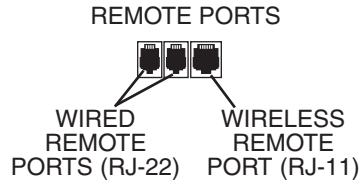

Special Note on T-Max®

The *Rejuvasun™ 332* requires the latest software in your T-Max Manager to properly control the sunbed. To check for this, when applying power to a Manager Pro a 3-digit version number will appear on the left-hand side of the screen. This must be 415 or higher. An upgrade CD is included with your sunbed. Follow the instructions on the CD.

T-Max® Wireless Remote System

The T-Max® AP-900 eliminates wires in your salon, allowing easy setup without hiring an electrician to run wires. It also protects your investment from damage by isolating each unit from one another. Your sunbed arrives “wireless ready”, which means it connects directly to the T-Max® wireless system. Older tanning beds, and T-Max® managers, also utilize this system but require a T-Max “Power Injector” (PI) to provide the needed power to the wireless unit.

Remote System Hook-up Scenarios

Follow the diagrams on the next page to see the many different scenarios for hooking up your salon. If you need further assistance, call T-Max® directly at 471-272-0761.



Scenario 1 - T-Max® Manager with Complete Wireless

Connect one AP-900 (with Power Injector) to the Manager and one AP-900 to each of the tanning beds. Install as many beds as you like with this configuration. Units that do not communicate with T-Max will need an AP-900 with Power Injector and an additional 3A to operate. You can place your sunbed at any location in the series.

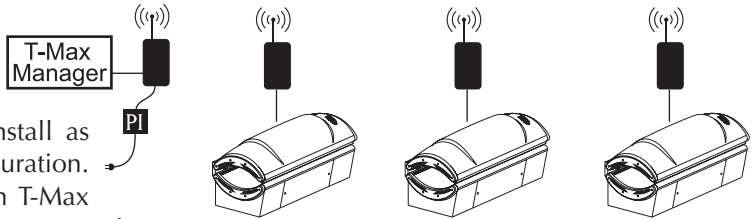

Scenario 2 - T-Max® Manager with Wireless combo

Wireless can be easily added to an existing salon already utilizing T-Max®. Connect one AP-900 (with Power Injector) to the Manager and one AP-900 to each wireless ready tanning bed. The rest of the salon may be “daisy-chained” together and connected to the Manager Pro.

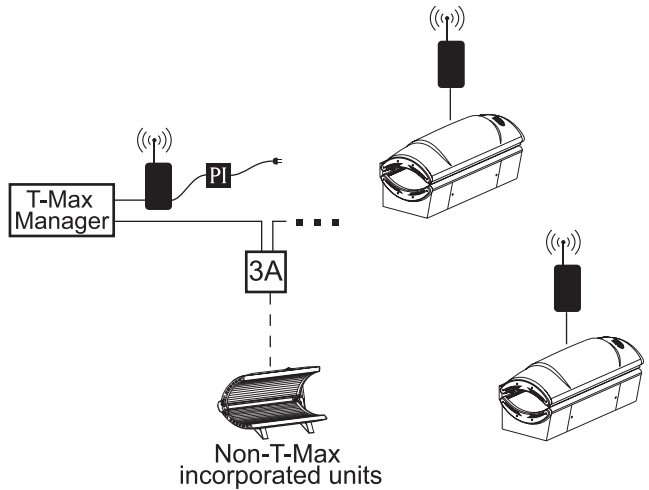

Scenario 3 - T-Max® Manager Series with Wireless combo

Connect one AP-900 (with Power Injector) to the Manager and one AP-900 to a wireless ready tanning bed. The rest of the salon may be “daisy-chained” together and connected to the wireless equipped tanning bed, eliminating the need to wire the Manager to the tanning beds.

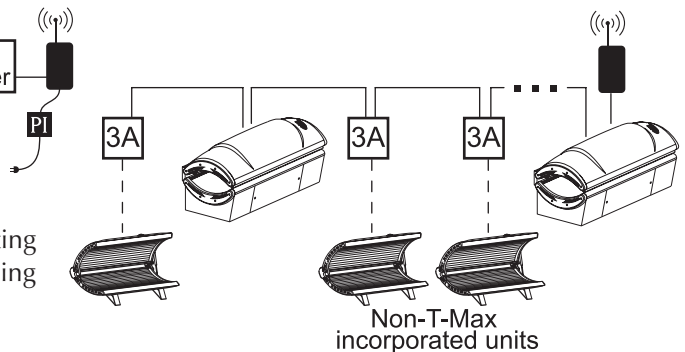



Scenario 4 - T-Max® Manager with wires

As always, this tanning bed is fully compatible with a wired T-Max® system. Simply connect the RJ-22 modular cable(s), described in the T-Max® Manager manual, into the remote port(s) located on the ballast drawer and follow the instructions that came with your remote system.

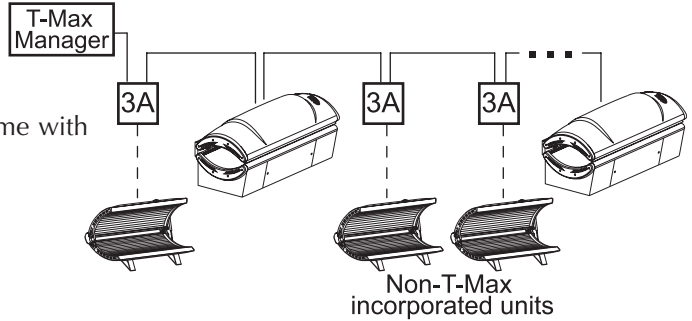

Scenario 7 - Non T-Max® Remote System wired to unit

Most non-T-Max® remote systems control the sunbed by the use of a relay. The relay operates the sunbed by connecting and disconnecting a pair of wires leading from the sunbed. Refer to the user's manual provided with your remote system to determine if it operates in this way. To connect your sunbed to this type of system a remote interface kit is required. Contact your place of purchase to obtain the kit. The illustration below details a typical connection. Follow the instructions provided with the kit and from the remote's manual to make the necessary connections.

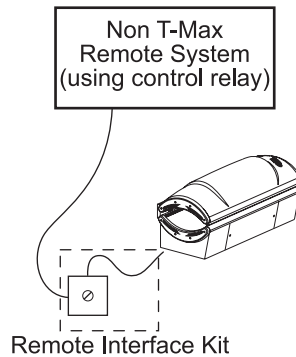

CAUTION

The remote connection is not designed to supply or accept high voltage, nor can it provide power to an external timer. The sunbed's remote interface circuitry operates on 5 volts, attempting to connect it to any higher voltages will damage the sunbed as well as void your warranty.



Setting the sunbed address manually

Before connecting your sunbed to the T-Max® Manager or T-Max® 1A or 3A, the address of your sunbed must first be set. Set the “id” manually as described below.

Setting the “id”

1. Make sure no cables are plugged into your sunbed’s remote ports.
2. Remove and reapply power to the unit.
3. Press and hold the stop button, located on the sunbed display, for three seconds and release. The display should indicate an “id” number from “0F” to “252”.

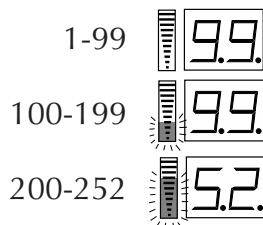

4. If you are using a T-Max® 1A or 3A as a “master” remote, the “id” of the sunbed must be set to “1”. If you are using a T-Max® Manager each sunbed must be assigned a different “id”. To set the “id” press the timer button, to count up, or the body fan control button, to count down, until the desired number is achieved.
5. Press the stop button to return to the normal display mode.



peration

Before You Tan

Before using your sunbed, please note the following important precautions.

- Your skin should be free of cosmetics, oils, or other body lotions prior to tanning except for those specifically made for use with tanning devices. However, do not remove natural body oils by bathing or showering immediately before tanning.
- Your hair should be free of gels, mousses, sprays, or other hair products prior to tanning. These products can cause damage to the sunbed acrylic. As an alternative, a shower cap or towel can be worn to keep treated hair away from the sunbed surfaces.
- This unit intended for individual use. Only one pair of eyewear is included.

⚠ DANGER

Some medication may increase your sensitivity to ultraviolet light. It is recommended that you consult a physician before using this sunbed if taking any medication or if you suspect that your skin might be especially sensitive to sunlight.

⚡ DANGER

Shock hazard.
Do not operate this device near water or while you are wet.

Exposure Times

Follow the guidelines for skin type and exposure times as shown in the table below. Untanned persons should not tan on consecutive days during their first week of tanning. Never tan more than once a day. Tanning normally appears after the first few sessions and maximizes after approximately four weeks. Tan once or twice per week thereafter to maintain appearance. Persons already having a base tan may begin at advanced levels corresponding to the extent of their base tan.

RECOMMENDED EXPOSURE TIMES IN MINUTES		MAXIMUM EXPOSURE TIME IS 20 MINUTES				
Skin Type:		Level 1/Week 1 1st-3rd Sessions	Level 2	Level 3	Level 4	Level 5
I Sensitive Skin (Burns easily and severely and does not tan.)		NOT RECOMMENDED FOR TANNING				
II Light	(Burns easily and severely and tans minimally.)	4	8	12	16	20
III Normal	(Burns moderately and tans average.)	6	10	15	20	20
IV Dark	(Burns minimally, tans easily and above average.)	8	12	16	20	20



Using Your Sunbed

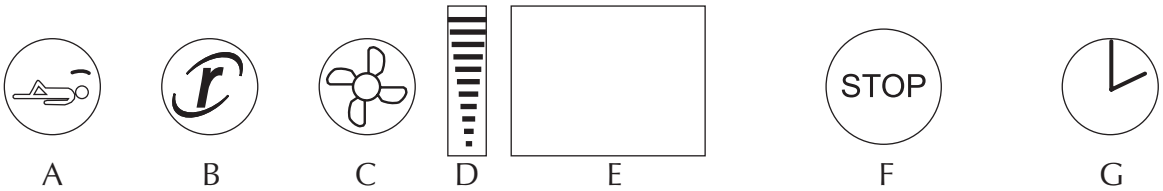

- A Face tanner control - Turns face tanners on and off during use.
- B Rejuvasun™ control - Turns Rejuvasun™ unit on and off.
- C Body fan control - Controls the speed of the body fan during use.
- D Body fan speed indicator - Indicates speed of fan. (OFF - LOW - MED - HIGH)
- E Timer display - Displays remaining time.
- F Stop button - Interrupts tanning session.
- G Timer button - Turns bed on. Timer display shows remaining time. If a lesser time is desired, press timer button until desired time is displayed (stand-alone mode only).

! WARNING

**Wear protective eyewear.
Failure to may result in severe burns or
longterm injury to the eyes.**



(Operation as a stand-alone unit or connected to a remote system using a control relay. If using T-Max® see right.)

1. Lift the canopy, lie down on the bench (face up), lower the canopy toward your body using the canopy handle. For best results, position the canopy as close to your body as possible, maintaining at least 4" (10.2 centimeters) from your body.
2. Put on your safety goggles.
- 3a. If you want a full tanning session, press the timer button (G, previous page) to begin the tanning session. The lamps will turn on, including rejuvasun™, and the timer will begin to count down.
- 3b. If you want to use the rejuvasun only, simply press the the rejuvasun button (B).
4. When the timer reaches "0" the lamps turn off. If you want to stop your session before time expires, press the stop button (F). You will have ten seconds to restart with the remaining time, otherwise the timer will reset to "0".
5. Raise the canopy by using the outer edge of the canopy, do not push up on the acrylic shield. The cooling fans run for a period of time after the lamps shut off to aid in cooling the sunbed.

(Operation while connected to a T-Max® remote system. If using other remotes or no remote system, see left.)

Note: See Remote Connections for important information about the T-Max remote system.

1. Lift the canopy, lie down on the bench (face up), lower the canopy toward your body using the canopy handle. For best results, position the canopy as close to your body as possible, maintaining at least 4" (10.2 centimeters) from your body.
2. Put on your safety goggles.
3. Assuming the remote system has been set to allow a pre-tanning delay time, the timer display (E) will repeatedly flash the delay symbol "dL" and then the remaining delay time. Press the timer button (G) or wait until the delay time has expired to begin the tanning session. The lamps will turn on and the timer will begin to count down.
4. When the timer reaches "0" the lamps turn off. If you want to stop your session before time expires, press the stop button (F).
5. Raise the canopy by using the outer edge of the canopy, do not push up on the acrylic shield. The cooling fans run for a period of time after the lamps shut off to aid in cooling the sunbed. The timer will indicate "." as a reminder to clean the sunbed. After the sunbed is cleaned press the timer button and the display will return to "0".



Cleaning After Use

Clean and disinfect your tanning bed's bench and canopy after each use. Use a non-abrasive disinfectant cleaner that **does not contain ammonia or ammonia derivatives**. Ammonia may damage the acrylic shield. Spray the acrylic lightly with disinfectant and wipe dry with a clean soft cloth. We recommend **Australian Gold® pH Neutral Disinfectant Cleaner**.

Thorough Periodic Cleaning

Introduction

The cooling fans draw air through the bed and over time will cause a dust buildup on the lamps and reflectors. This will reduce the tanning effectiveness of the bed. When a dust buildup is observed, it is necessary to thoroughly clean the inside of the bench and canopy.

	⚠ WARNING
	Shock hazard. Disconnect power before removing any protective covers.

Cleaning the Canopy and Bench

Step 1 Open the acrylic shields and remove lamps as described in Lamp and Acrylic Replacement.

Step 2 With a soft cloth, wipe the entire length of each lamp to remove any film buildup.

Step 3 Clean both sides of the acrylic shields with a non-ammonia disinfectant cleaner.

Step 4 Wipe the reflectors with a clean damp cloth.

Step 5 Reinstall the lamps and acrylic shields.

Step 6 Clean or replace air filter on top of ballast tray. Replace with a 10" x 24" x 1" furnace filter.

Mechanical Inspection

Your tanning bed has been built for years of service. To ensure trouble-free operation throughout its life, inspect the unit's mechanical integrity every 400-500 hours of use.

- Inspect the unit's fasteners verifying that all are firmly in place.
- Inspect gas springs for signs of wear. Gas springs that will not hold the canopy in the full open position when raised should be immediately replaced. See Troubleshooting.
- Inspect the AC power cord and its connections.
- Inspect the acrylic. Broken, cracked or badly scratched acrylics should be immediately replaced.



Lamp and Acrylic Replacement

Introduction

To be assured of maximum tanning effectiveness, change lamps after approximately 700-1000 hours of use. Tanning will continue after this time but at a slower rate. To ensure trouble-free operation of your sunbed, replace the lamp starters whenever the lamps are replaced.

Opening/Replacing Acrylic Shields

The acrylic shields are secured in place by turn latches along the front edge. Use a flat-bladed screwdriver to turn the latches a quarter turn to open the acrylic. The acrylics swing open on a hinge. On the inside of the bench, along the front, are two supports for the bench acrylic. Swing them up to hold the bench acrylic open. Both acrylics may be removed by lifting them out of the channel along the back edge.

When you are finished, simply reverse the above directions to secure the acrylic shields.

CAUTION

Be careful. The edges of the acrylic shield may be sharp.

WARNING



Shock hazard.
Disconnect power before removing any protective covers.

Rejuvasun™ Unit Maintenance

The rejuvasun™ facial unit requires no regular maintenance, except to make sure it is free of dust. Carefully wipe it with a clean, dry, soft cloth.



Removing/Replacing Fluorescent Lamps

After opening the acrylic shield, replace lamps as follows.

Step 1 Grasp the lamp at one end and at the middle and turn the lamp one quarter turn. Gently remove the lamp from its holders.

Step 2 Reinstall the lamp by inserting the pins located on the ends of the lamp into the slots on top of the lamp holders and turn the lamp a quarter turn. It should click in place.

Recommended Replacement Lamps

We recommend using the lamps specified below. Use of uncertified lamps is a violation of Federal regulations and will void your warranty. These lamps have an average life of 700-1000 hours of effective tanning use. Lamps used longer than that begin to lose their effectiveness even though they continue to light.

Recommended Replacement Acrylics

Acrylics vary greatly over time in their ability to effectively transmit UV light. Acrylics sold by ETS have been life tested to ensure proper transmission throughout their useful life.

ONLY THE FOLLOWING LAMPS HAVE BEEN CERTIFIED FOR USE IN THIS EQUIPMENT:

Bench lamps

Velocity® Wolff® Model VEL71-T12 / 100W PREHEAT-BIPIN

Canopy lamps

Velocity® PLUS Wolff® Model VLP71-T12-100W Bi-Pin

SolarMax™ IFT facial unit : if equipped

Heraeus E400 HPT -or- Philips Model HPA 400/30s -or- CosmoTech Model 23045



Removing/Replacing Face Tanner Lamp

After removing the canopy acrylic shield, replace the face tanner lamp as follows:

Step 1 Support the face tanner assembly with your hand while unscrewing the two retaining screws. The face tanner glass casing will swing downward.

Step 2 The lamp can now be exchanged. The lamp holders are equipped with spring contacts which enable the lamp to be removed easily. Remove the old lamp and discard. Install the new lamp, using a clean cloth or paper towel. Ensure that the lamp is firmly seated in the lamp holders.

Note! Never take hold of the lamp such that your fingers are in contact with the lamp glass. Finger oils will greatly reduce the lamp's operational life.

Step 3 Gently close the face tanner glass casing and lock it closed with the screws. Ensure that the screws firmly secure the glass casing.

! DANGER

Unfiltered light from face tanner can cause severe burns.

Never turn sunbed on while face tanner is disassembled or when glass filters are removed.

Immediately discontinue use of this equipment if face tanner glass is broken or any unfiltered light can be seen escaping face tanner assembly.

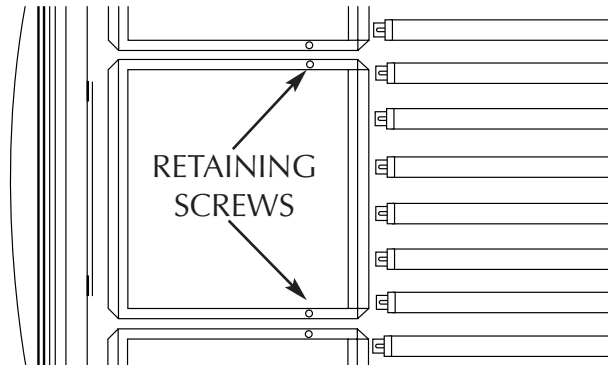

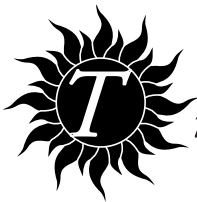

Problem	Solution
Sunbed not tanning	<ol style="list-style-type: none"> 1. Clean sunbed, see Thorough Periodic Cleaning. 2. Ensure supply voltage is between 208 and 230V AC. 3. Replace lamps if lamp hours are greater than 800hrs. 4. Replace acrylic.
Lamps fail to light and timer display is blank	<ol style="list-style-type: none"> 1. Make sure the unit is connected to a power source. 2. Check source of AC power. Reset circuit breaker or replace fuse.
One or more lamps fail to light	<ol style="list-style-type: none"> 1. Check that lamp is installed correctly. 2. Switch unlit lamp with a lamp that lights, if new lamp lights and old lamp still does not, replace old lamp.
The canopy will not stay up	<p>NOTE: Gas springs are manufactured to hold the canopy in its fully open position as well as allow it to rest fully closed. If left open for an extended period of time some creep down may occur. This is considered normal. Keep the unit closed when not in use. If the canopy will not stay fully open when raised...</p> <ol style="list-style-type: none"> 1. Raise and lower the canopy a few times to lubricate gas spring internal seals. 2. Replace gas springs.
The face tanners will not come on	<ol style="list-style-type: none"> 1. Face tanner operation is initially delayed by 5 seconds. 2. Face tanners will not relight for 1 minute if turned off. 3. Replace face tanner lamp, see Removing/Replacing Face Tanner Lamp.
The last minute of tanning time does not count down from 59 seconds, but some time less than 59 seconds	<p>If the timer button has been pressed to decrease tanning time during the session, the time expired in the current minute is subtracted from the last minute.</p>
I forgot what address, or "id", I set my sunbed to	<p>By holding the body fan button for 3 seconds the timer display will briefly display three numbers; the installed timer software version, a factory set timer code and then the sunbed's "id" number.</p>



Problem	Solution
Timer display is indicating Er 91	Timer software error. Disconnect and reapply power to the unit.
Timer display is indicating Er 92	Current sensor indicating unit is off when it should be on. Contact servicer.
Timer display is indicating Er 93	Current sensor indicating unit is on when it should be off. Contact servicer.
Timer display is indicating Er 94	Requested session time exceeds maximum time allowed.
Timer display changes to indicate a tanning time after the timer button is pressed but lamps do not come on	<ol style="list-style-type: none"> 1. Bypass plug is not installed, see Electrical Connections. 2. A non-SunStar® bypass has been used. See Electrical Connections. 3. If remote is being used, other than T-Max® Manager, the external timer may not be activated. 4. Remote wiring is incorrect, see the instructions provided with the remote interface kit.
My bed is connected to the T-Max® Manager remote system and when the delay time has expired the timer display starts counting down but the bed lights do not come on	The auto start feature of the remote system is disabled, see the instructions provided with your remote system.
My bed won't work with the T-Max® Manager remote system	<ol style="list-style-type: none"> 1. The sunbed must first be set to a unique address, see Remote Connections. 2. The bypass or terminator plug may be installed in the series in an inappropriate location. Plug the bypass plug only into the bed at the end of the series.
Timer display continues to show a 0 after the timer button is pressed	<ol style="list-style-type: none"> 1. T-Max® Manager remote system has not yet been set. 2. Sunbed address is not set correctly, see Remote Connections.



Problem	Solution
My bed is connected to a T-Max® remote system but I am having trouble getting into “id” mode	You have probably attempted to connect your sunbed to the remote system already. Disconnect the remote plug(s) from the ports at the back of the sunbed, wait 90 seconds and try again.
My bed, connected to a T-Max® Manager, did not display “dL” but does indicate: “0” a tanning time and the lamps have come on a tanning time but the lamps have not come on	<ol style="list-style-type: none"> 1. Remote device has not been set. 2. The sunbed has not been connected to the remote system, see Remote Connections. <ol style="list-style-type: none"> 1. Delay time of T-Max® Manager has not been set. 2. Delay time has expired and session has begun. Auto start function of T-Max® Manager has been turned off. Press the timer button to turn on lamps.
When auto-addressing the first bed does not register an “id”	When using the auto address feature of the T-Max® Manager you must wait 10 seconds from the time you start the auto address function before addressing the first bed.
When using a T-Max® 1A my sunbed won’t function properly	SunStar® Bypass plugs or terminator plugs may be needed if the T-Max® 1A and the sunbed are over 100 feet apart. Install the plugs in the open remote port in the sunbed and the T-Max® 1A.
My salon suffers frequent, short power outages and clients complain about losing session time	If you have a T-Max® Manager, changing parameter 23 from “0” to “1” will allow the tanning bed to remember how much time was left when power goes out and resume its session after power is restored. Consult your T-Max® Manager manual for information on setting parameters.

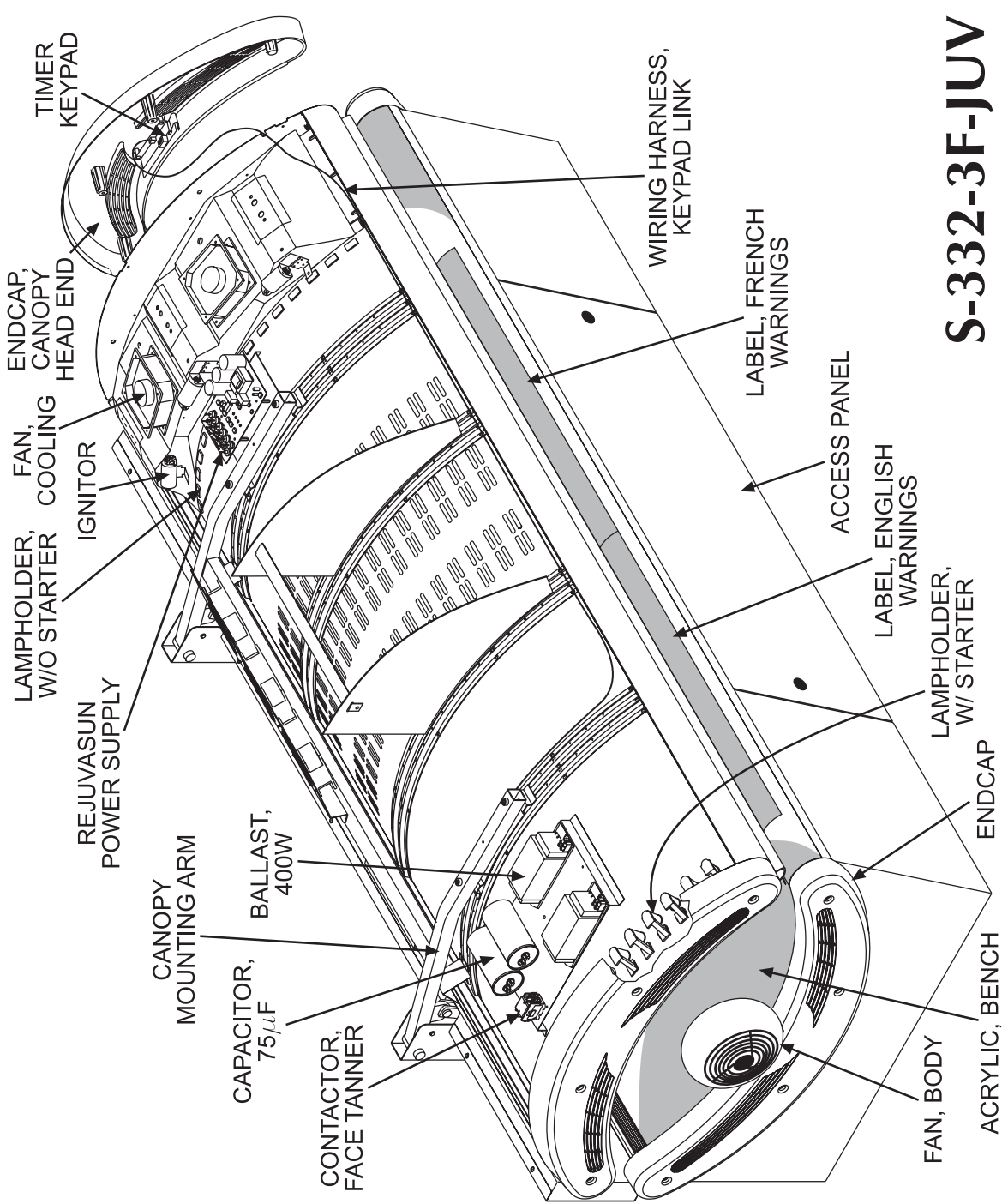

S-332-3F-JUV

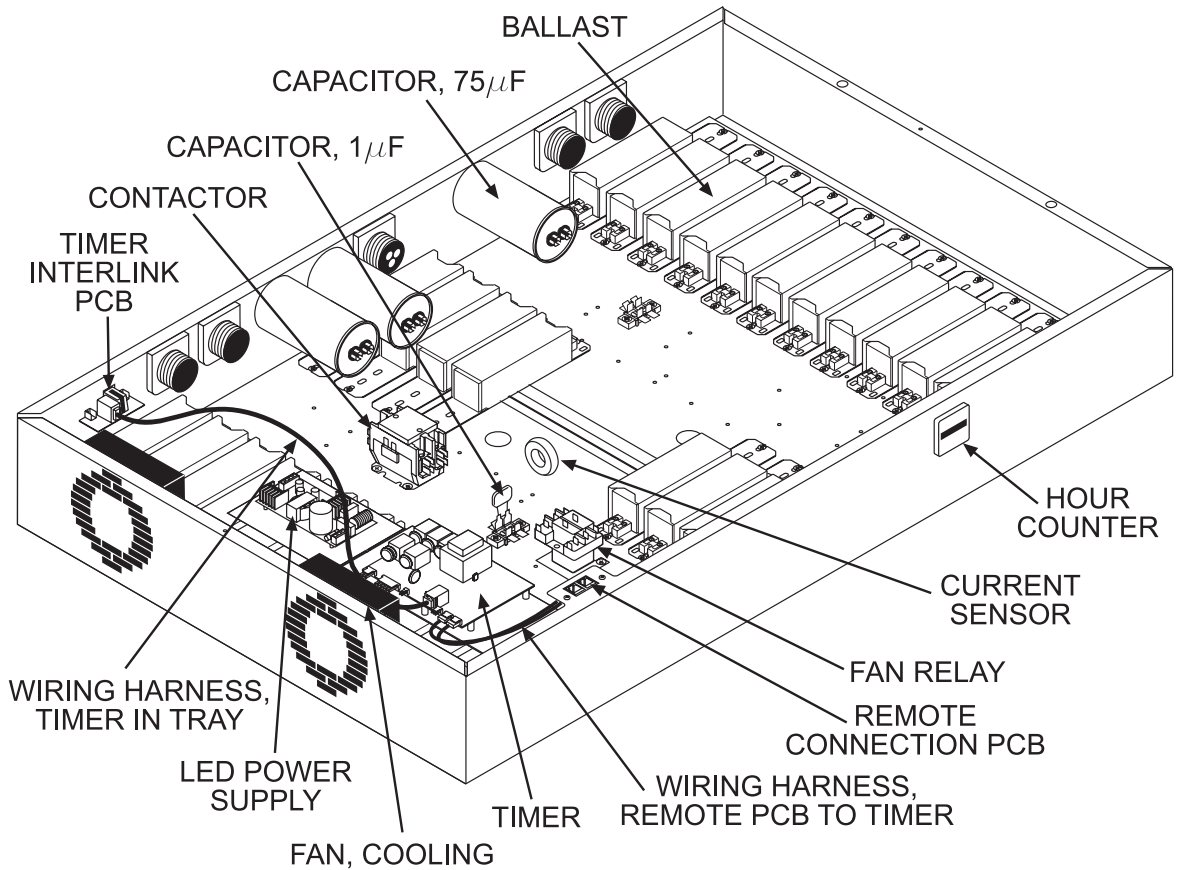

Ballast Tray

Parts List

This is a list of parts which may be replaced by the consumer. Care should be taken when replacing anything related to electrical wiring. We recommend contacting a professional electrician. When calling for parts, first state your bed model as S-332-3F-JUV. Then refer to this list and preceding illustrations for proper part identification.

Access Panel
Access Panel Key*
Acrylic, Bench
Acrylic, Canopy*
Acrylic Edge Trim, Canopy*
Acrylic Protector Strip* (on bench support rail)
Ballast, 100W
Ballast, Face Tanner 400W
Bearing, Nylon Floating*
Bushing, Bronze 10mm*
Canopy Mounting Arm
Capacitor, 1 μ F
Capacitor, 75 μ F
Contactor
Contactor for Face Tanner
Cover, Canopy*
Current Sensor
Endcap
Endcap, Canopy Head End
Endcap, with Body Fan Cut-outs
Face Tanner Assembly, Outer*
Fan Body
Fan, Cooling
Fan Grill, Plastic*
Fan Relay
Filter*
Gas Springs*

Hardware Kit, Complete*
Hardware Kit, Assembly*
Hour Counter*
Ignitor
Label, English Warnings
Label, French Warnings
Lamp Holder w/ Starter
Lamp Holder w/o Starter
Lamp Holder, Face Tanner*
Lamps*
LED Accent Light*
LED Power Supply
Pillow*
Remote Connection PCB
Remote Control Bypass Plug*
Rejuvasun™ Panel*
Rejuvasun™ Power Supply
Schematic Packet*
Starter, Electronic (main lamps)
Support, Bench Acrylic*
Thermostat* (for face tanner)
Timer
Timer Interlink PCB
Timer Keypad
Timer Keypad Pushbuttons*
Trim Profile (grey)
Wiring Harness, Keypad Link
Wiring Harness, Remote PCB to Timer
Wiring Harness, Timer in Tray
Wiring Harness, RJ-11 Canopy to Tray*

Record this information for ease of service:

Date of purchase: _____

Serial number: _____

* Not shown

What to do	WHEN			
	After each use	Monthly	400-500hrs	700-1000hrs
A. Clean/Disinfect Interior Surfaces*	✓			
B. Clean Lamps*		✓		
C. Clean Reflectors*		✓		
D. Clean Exterior		✓		
E. Check/Clean Fans†		✓		
F. Change Lamps**				✓
H. Check Fasteners (nuts, bolts, etc.)*			✓	
I. Check Power Cords*			✓	
J. Change Filter*			✓	

* See *Care and Maintenance*

** See *Lamp and Acrylic Replacement*

† Fans are located on top of the canopy, under the bench and at the side of the ballast drawer. Use a vacuum to clean.

MAINTENANCE LOG					
What	When	What	When	What	When
example B C D E	4/15/07				

Rejuvasun™ 332

Size

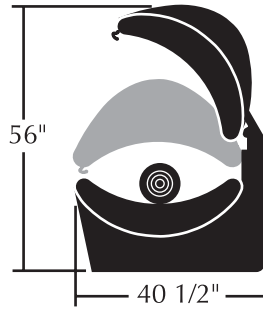
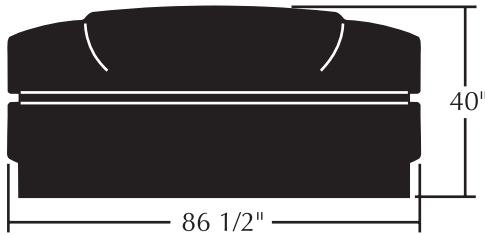

Weight (Pounds)	530
Recommended Room Size	7' x 9'
Electrical -	
Voltage (AC)	220
Amperage	17A
Circuit Breaker (Recommended min.)	30A
Outlet	Hardwire
Main Lamps (bench)	Velocity®
Main Lamps (canopy)	Velocity® PLUS
Ballasts	100W
Face Tanner	SolarMax™ IFT
FT Ballasts	400W
Body Cooling System plus	Full side fan panel 230cfm "Turbo"
Timer System	Digital
Max. Exposure Time	20min. tanning / 20min. Rejuvasun™
Back-up Timer	On-board "Watchdog"
Remote Capability	T-Max® compatible



**Proudly manufactured
in the U.S.A.**

