

ELITE TOTAL BODY **RECUMBENT** **BIKE**

Owner's Manual

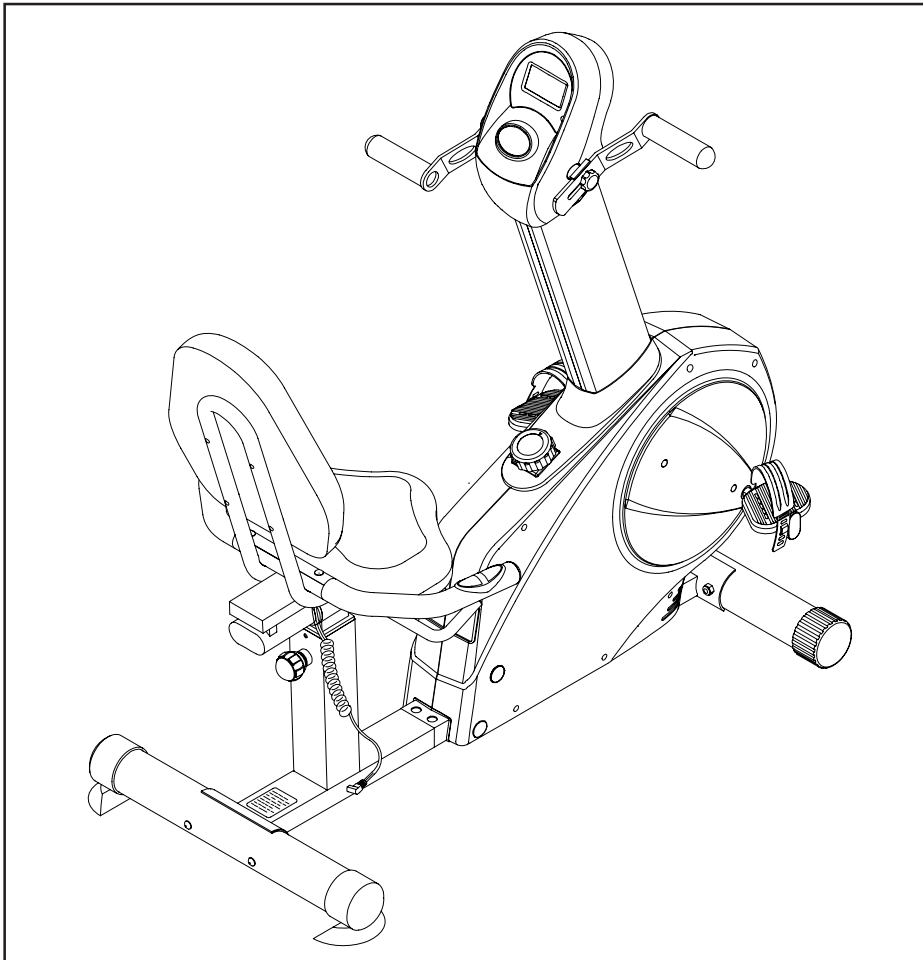

CAUTION:
Weight on this product should not exceed 250 lbs.

! WARNING !

Exercise can present a health risk. Consult a physician before beginning any exercise program with this equipment. If you feel faint or dizzy, immediately discontinue use of this equipment. Serious bodily injury can occur if this equipment is not assembled and used correctly. Serious bodily injury can also occur if all instructions are not followed. Keep others and pets away from equipment when in use. Always make sure all bolts and nuts are tightened prior to each use. Follow all safety instructions in this manual.

When calling for parts or service, please specify the following number.

15-9100
STAMINA PRODUCTS
MADE IN TAIWAN

Product May Vary Slightly
From Pictured.

This Product is Produced Exclusively by



2040 N. Alliance, Springfield, MO 65803
Customer Service Number
1 (800) 375-7520
www.staminaproducts.com

TABLE OF CONTENTS

	Page		Page
Safety Instructions	2	Maintenance	13
Before You Begin	4	Conditioning Guidelines	14
Hardware Identification Chart	5	Warm-up and Cool-Down	15
Assembly Instructions	6	Product Parts Drawing	16
Using The Electronic Meter	10	Parts List	17
Set Up Instructions	11	Warranty	19
Operational Instructions	12	Notes	20
Storage	13	Fax/Mail Ordering Form	22

SAFETY INSTRUCTIONS

WARNING: To reduce the risk of serious injury, read the following Safety Instructions before using the **TOTAL BODY RECUMBENT BIKE**.

1. Read all warnings posted on the **TOTAL BODY RECUMBENT BIKE**.
2. The **TOTAL BODY RECUMBENT BIKE** should only be used after a thorough review of the Owner's Manual.
3. We recommend that two people be available for assembly of this product.
4. Keep children away from the **TOTAL BODY RECUMBENT BIKE**. Do not allow children to use or play on the **TOTAL BODY RECUMBENT BIKE**. Keep children and pets away from the **TOTAL BODY RECUMBENT BIKE** when it is in use.
5. Make sure that the **TOTAL BODY RECUMBENT BIKE** is properly assembled and tightened before use.
6. It is recommended that you place this exercise equipment on an equipment mat.
7. Set up and operate the **TOTAL BODY RECUMBENT BIKE** on a solid level surface. Do not position the **TOTAL BODY RECUMBENT BIKE** on loose rugs or uneven surfaces.
8. Adjust the STAND(65) under the REAR FRAME(2) to get more support for the base of the **TOTAL BODY RECUMBENT BIKE**.
9. Inspect the **TOTAL BODY RECUMBENT BIKE** worn or loose components prior to use. Tighten/replace any loose or worn components prior to using.
10. The ADJUSTMENT KNOBS(52) and SPRING KNOB(64) should be securely tightened prior to use.
11. Each user should adjust the seat per instructions on page 12.
12. Do not attempt to adjust the seat while you are on the **TOTAL BODY RECUMBENT BIKE**.
13. Consult a physician prior to commencing an exercise program. If, at any time during exercise, you feel faint, dizzy, or experience pain, stop and consult your physician.
14. Follow your physician's recommendations in developing your own personal fitness program.
15. Always choose the workout which best fits your physical strength and flexibility level. Know your limits and train within them. Always use common sense when exercising.
16. Do not wear loose or dangling clothing while using the **TOTAL BODY RECUMBENT BIKE**.
17. Never exercise in bare feet or socks; always wear correct footwear, such as running, walking, or crosstraining shoes. Be sure that they fit well, provide foot support and feature non-skid rubber soles.
18. Care should be taken in mounting or dismounting the **TOTAL BODY RECUMBENT BIKE**.
19. The **TOTAL BODY RECUMBENT BIKE** should not be used by persons weighing over 250 pounds.
20. The **TOTAL BODY RECUMBENT BIKE** should be used by only one person at a time.
21. The **TOTAL BODY RECUMBENT BIKE** is for consumer use only. It is not for use in public or semipublic facilities.

WARNING: Before starting any exercise or conditioning program you should consult with your personal physician to see if you require a complete physical exam. This is especially important if you are over the age of 35, have never exercised before, are pregnant, or suffer from any illness. **READ AND FOLLOW THE SAFETY PRECAUTIONS. FAILURE TO FOLLOW THESE INSTRUCTIONS CAN RESULT IN SERIOUS BODILY INJURY.**

CALL US FIRST



CUSTOMER SERVICE NUMBER
1 (800) 375-7520

**THANK YOU FOR PURCHASING THE
TOTAL BODY RECUMBENT BIKE**

To help you get started, we have pre-assembled most of your TOTAL BODY RECUMBENT BIKE at the factory with the exception of those few parts left unassembled for shipping purposes. Simply follow the few assembly instructions set forth in this manual. Within a few minutes you will be getting your body into shape and on your way to achieving a happier and healthier lifestyle.

Should you have any questions,
please call our Customer Service Department toll-free number,
1 (800) 375-7520
Monday - Friday, 8:00 A.M. - 5:00 P.M., Central Time.

BEFORE YOU BEGIN

Thank you for choosing the **TOTAL BODY RECUMBENT BIKE**. We take great pride in producing this quality product and hope it will provide many hours of quality exercise to make you feel better, look better and enjoy life to its fullest.

Yes, it's a proven fact that a regular exercise program can improve your physical and mental health. Too often, our busy lifestyles limit our time and opportunity to exercise. The **TOTAL BODY RECUMBENT BIKE** provides a convenient and simple method to begin your assault on getting your body in shape and achieving a happier and healthier lifestyle.

Before reading further, please review the drawing below and familiarize yourself with the parts that are labeled.

Read this manual carefully before using the **TOTAL BODY RECUMBENT BIKE**.

Although Stamina tries to manufacture its products with the finest materials and uses the highest standards of manufacturing, occasionally a part that does not fit, is the incorrect size, or is otherwise inappropriate is found. Even with the highest inspection and quality controls in place these things will happen occasionally. Please do not return the product. For your convenience, Stamina has a Customer Service Department with a toll-free number. If a part is missing, does not fit, is the incorrect size, or is otherwise inappropriate, please call 1 (800) 375-7520 (in the U.S.) between 8:00 A.M. and 5:00 P.M. Central Time, Monday through Friday. Our operators will be able to assist you with your problem and the parts will be mailed directly to your house.

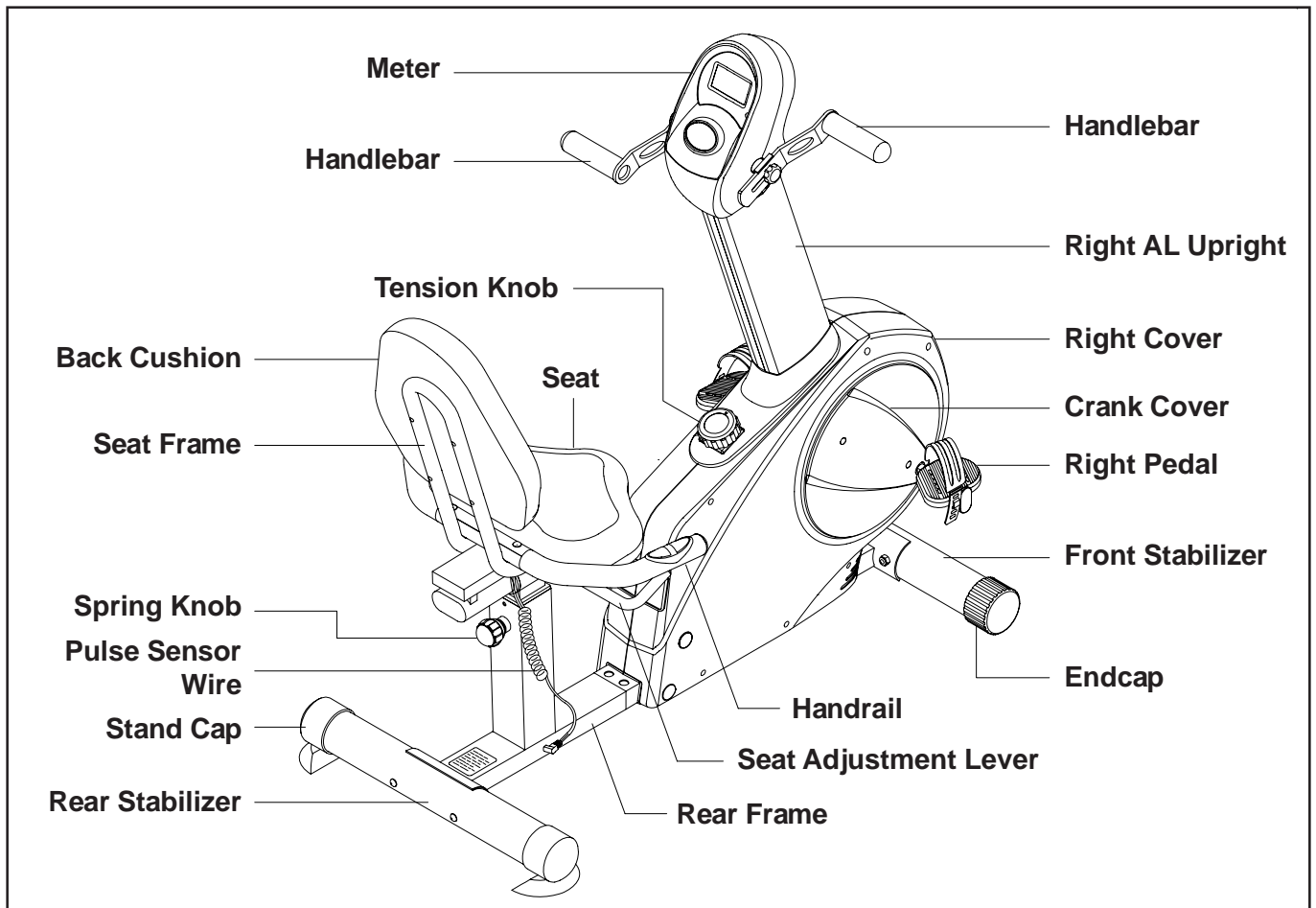

THE FOLLOWING TOOLS ARE INCLUDED FOR ASSEMBLY :



Allen Wrench (4mm)

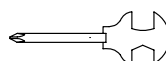

Combination Wrench (13mm and 15mm)

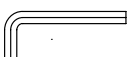

Allen Wrench (6mm)

HARDWARE IDENTIFICATION CHART

This chart is provided to help identify the hardware used in the assembly process. After unpacking the unit, open the hardware bag and make sure that you have the following items:

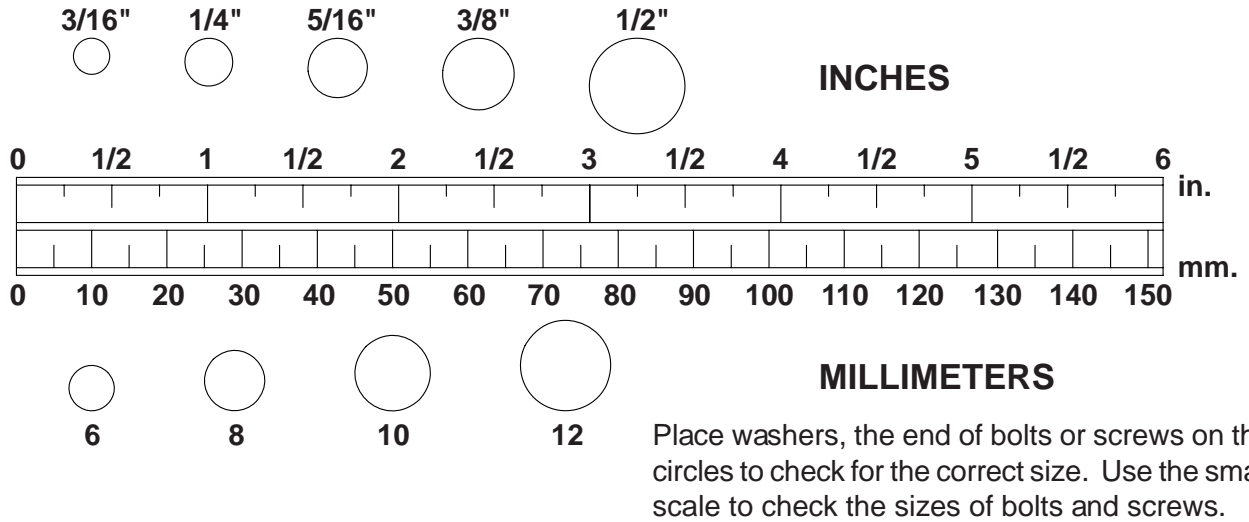

	Part No. and Description	Qty
	79 Carriage Bolt (M8 x 1.25 x 85mm)	4
	99 Carriage Bolt (M8 x 1.25 x 50mm)	2
	96 Bolt, Hex Head (M8 x 1.25 x 40mm)	4
	97 Bolt, Hex Head (M8 x 1.25 x 15mm)	4
	85 Bolt, Socket Head (M8 x 1.25 x 50mm)	3
	80 Nylock Nut (M8 x 1.25)	10
	74 Washer (M8)	2
	98 Set Screw (M6 x 1 x 15mm)	2

NOTE: Some of the hardware items listed may be attached to other parts.

ASSEMBLY INSTRUCTIONS

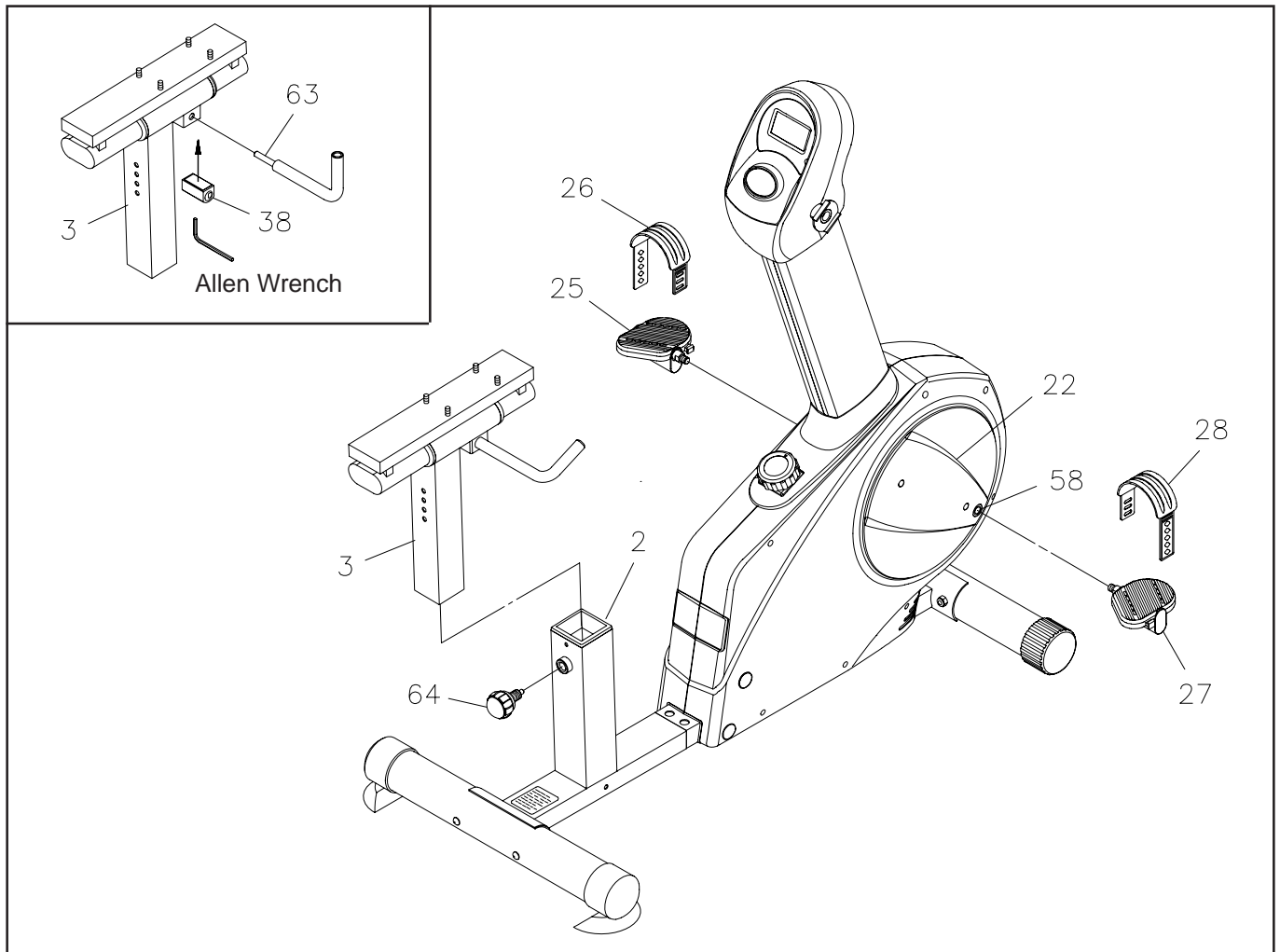

STEP 4

NOTE: The **RIGHT PEDAL(27)** has **R** stamped on the end of the pedal shaft. The **RIGHT PEDAL(27)** has right hand threads and is tightened by turning clockwise. The **LEFT PEDAL(25)** has **L** stamped on the end of the pedal shaft. The **LEFT PEDAL(25)** has left hand threads and is tightened by turning counter clockwise.

Thread the **RIGHT PEDAL(27)** onto the **RIGHT CRANK(58)** located inside the **CRANK COVER(22)** as shown. Tighten the pedal securely. Select the **RIGHT PEDAL STRAP(28)** which has **R** marked on the bottom side of the strap. Snap the three hole end onto the inside edge of the **RIGHT PEDAL(27)**. Snap the other end onto the outside edge of the **RIGHT PEDAL(27)** with the **R** mark on the bottom of the **RIGHT PEDAL STRAP(28)**. Select adjustment holes which allow your foot to be easily removed from the pedals. Use the same procedure to attach the **LEFT PEDAL(25)** onto the **LEFT CRANK(57)** and snap the **LEFT PEDAL STRAP(26)** onto the **LEFT PEDAL(25)**.

STEP 5: Refer to the inset drawing. Insert the **ADJUSTMENT BLOCK(38)** into the **SEAT POST(3)**. Insert the **SEAT ADJUSTMENT LEVER(63)** through the **SEAT POST(3)** and **ADJUSTMENT BLOCK(38)** and secure by tightening the set screws inside the **ADJUSTMENT BLOCK(38)** with Allen Wrench.

STEP 6: Insert the **SEAT POST(3)** into the **REAR FRAME(2)** and secure with the **SPRING KNOB(64)**. **NOTE:** The **SPRING KNOB(64)** should be screwed in tight to make the **SEAT POST(3)** fit securely in the **REAR FRAME(2)**.

ASSEMBLY INSTRUCTIONS

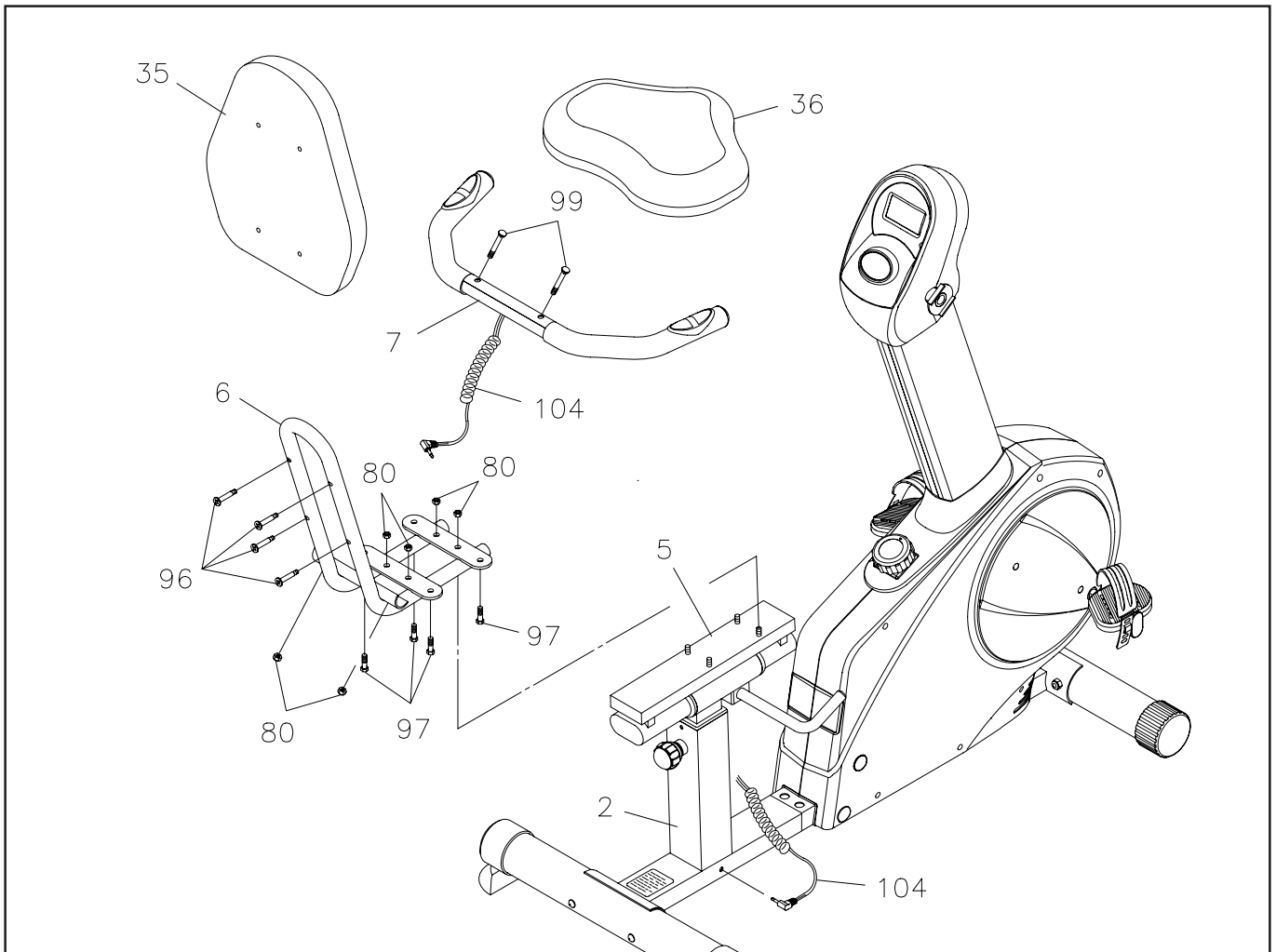

NOTE: Be careful not to damage the **PULSE SENSOR WIRES(104)** while doing assembly Step 8 and Step 9.

STEP 7

Attach the **SEAT FRAME(6)** onto the **SEAT SUPPORT TUBE(5)** with **NYLOCK NUTS(M8)(80)**.

STEP 8

Attach the **HANDRAIL(7)** onto the **SEAT FRAME(6)** with **CARRIAGE BOLTS(M8 x 50mm)(99)** and **NYLOCK NUTS(M8)(80)**. Run the **PULSE SENSOR WIRES(104)** through the upright of the **SEAT FRAME(6)** and plug it into the socket on the **REAR FRAME(2)**.

STEP 9

Attach the **SEAT(36)** onto the **SEAT FRAME(6)** with **HEX BOLTS(M8 x 15mm)(97)**. Attach the **BACK CUSHION(35)** onto the **SEAT FRAME(6)** with **HEX BOLTS(M8 x 40mm)(96)**.

ASSEMBLY INSTRUCTIONS

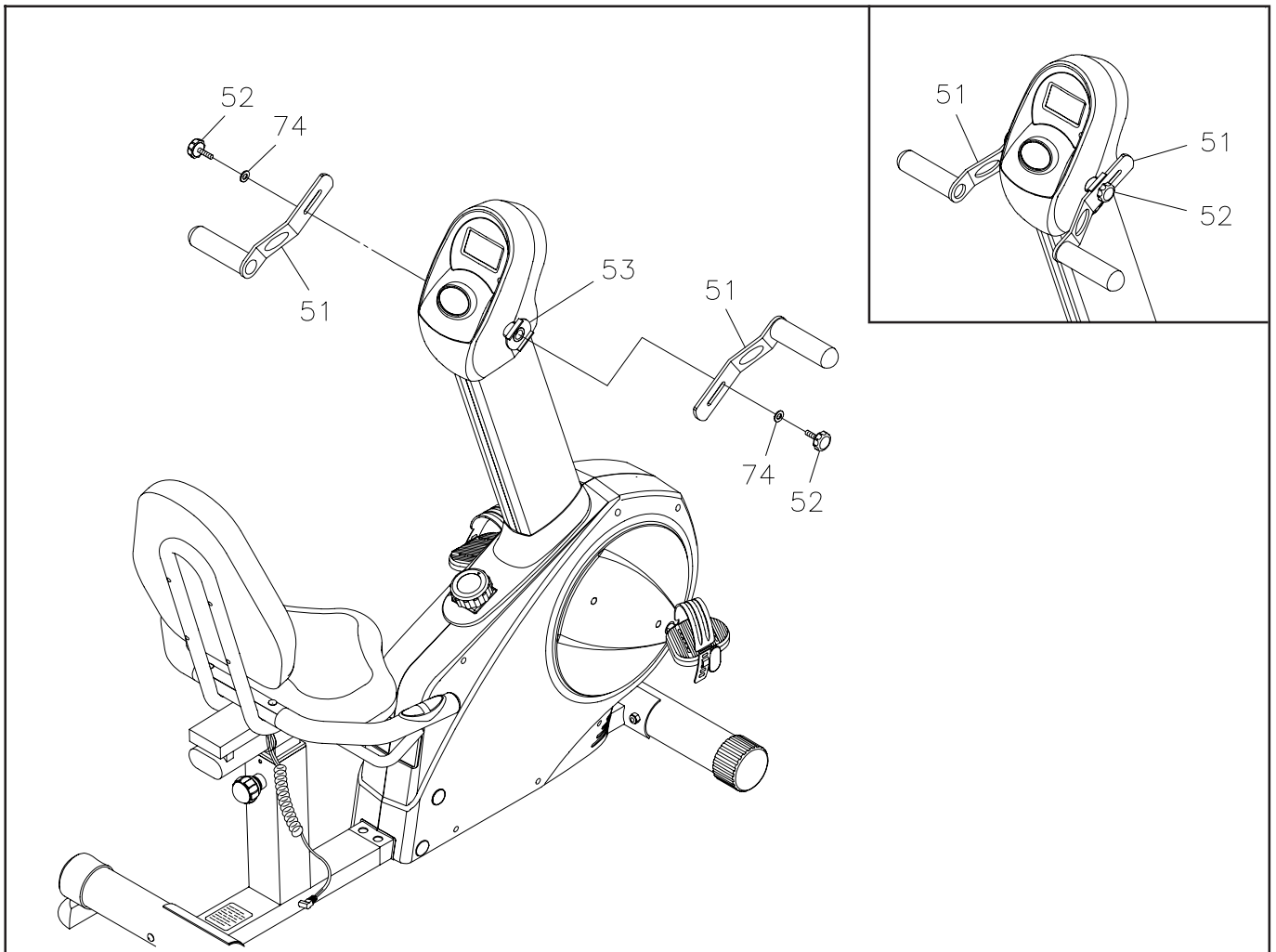

STEP 10

Attach the **HANDLEBARS(51)** onto the **MOUNTING BRACKETS(53)** with the **ADJUSTMENT KNOBS(52)** and **WASHERS(M8)(74)**.

NOTE: The **HANDLEBARS(51)** may be assembled in two configurations. Refer to the inset drawing.

USING THE ELECTRONIC METER

POWER ON: Pedal movement or press any button.

POWER OFF: Automatic shut off after 4 minutes of inactivity.
Resets all values to zero.

FUNCTION BUTTONS:

MODE : Press and release to select each functions for display or preset target values.

ENTER : Press to enter the setting and confirm the selected values of the setting mode.

UP & DOWN: These two buttons set target values for TIME, CALORIE, PULSE, and DISTANCE.

RESET : This button will reset each function to zero.
To reset all functions to zero, press the button and hold it down for two seconds.

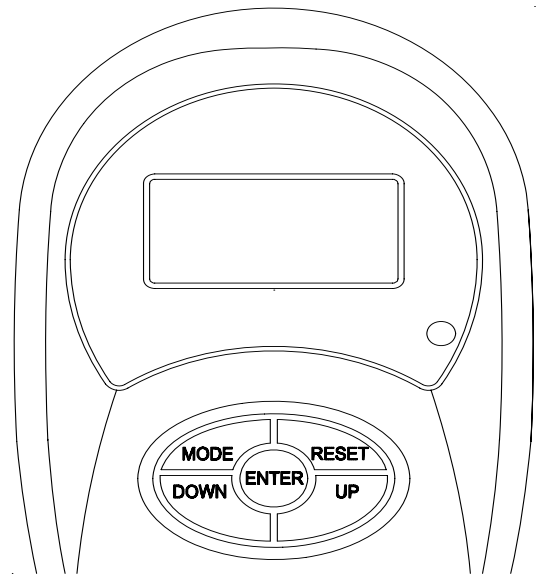

PRESET VALUES OPERATION:

Stop pedaling for four seconds. Press the **ENTER** button to go to setting mode. The meter will cycle through the functions as follows and allow you to set the function values.

Time (0:00 to 99:00) → Calories (0.0 to 999.0 Kcal) → Pulse (90 to 220 BPM) → Distance (0.0 to 999.9 mile)

Use **UP & DOWN** buttons to enter desired values and press **ENTER** button to confirm. Or, just press the **ENTER** button to pass the setting of some functions. Press the **ENTER** button to start to workout after the setting.

FUNCTIONS:

SCAN: Automatically scans **TIME, SPEED, CALORIE, PULSE,** and **DISTANCE** in sequence with a change every six seconds. Press and release the **MODE** button until the "**SCAN**" appear on display.

TIME: Counts upward to 99:59 in one second increments once the meter is turned on. Counts down from preset value.

SPEED: Displays the current speed, from zero to 45 Mile/Hr.

CALORIE: Displays the calorie consumption, from zero to 999.9 Kcal. Counts down from preset value.

The calorie readout is an estimate for an average user. It should be used only as a comparison between workouts on this unit.

DISTANCE: Displays distance up to 999.9 miles in increments of 0.01 miles. Counts down from preset value.

PULSE: Displays your pulse rate in beats per minute. To display pulse, select the PULSE MODE and grasp the pulse sensors on the handrail, one in each hand. The heart icon will begin flashing when the ELECTRONIC METER senses your pulse. Your pulse will be displayed approximately five (5) seconds after the heart icon is displayed. If the heart icon does not appear, relax your grip or change your grip on the pulse sensors.

If you preset the PULSE value, the meter will warn you with an audible alarm when your pulse exceeds the set value. Stop exercising until your pulse comes down.

HOW TO INSTALL AND REPLACE BATTERIES:

1. Open the Battery Door on the back of the meter.
2. The meter operates with two AA batteries, two batteries included. Refer to the illustration to install or replace the batteries.

NOTE:

1. Do not mix a new battery with an old battery.
2. Use the same type of battery. Do not mix an alkaline battery with another type of battery.
3. Rechargeable batteries are not recommended.

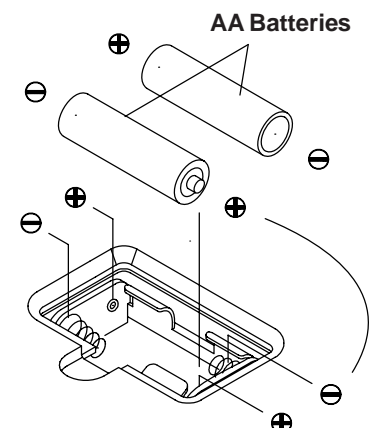

SET UP INSTRUCTIONS

Place the **TOTAL BODY RECUMBENT BIKE** in the area where it will be used. It is recommended that the **TOTAL BODY RECUMBENT BIKE** be placed on an equipment mat. The **TOTAL BODY RECUMBENT BIKE** is approximately 49 5/8" long x 23 5/8" wide x 48 5/8" tall. (These dimensions may vary up to one inch.) An area 4 feet wide x 6 feet long is required for safe operation of the **TOTAL BODY RECUMBENT BIKE**. Make sure that adequate space is available for access to and passage around the **TOTAL BODY RECUMBENT BIKE**.

LEVELING: Place the **TOTAL BODY RECUMBENT BIKE** on a flat surface and equipment mat to set it on the floor without rocking. Adjust the **STAND(65)** under the **REAR FRAME(2)** to get more support for the base of the **TOTAL BODY RECUMBENT BIKE**.

MOVING: The **TOTAL BODY RECUMBENT BIKE** has a pair of **WHEELS(76)** on the **FRONT STABILIZER(8)**. Lift up from **REAR STABILIZER(9)** to move the **TOTAL BODY RECUMBENT BIKE**.

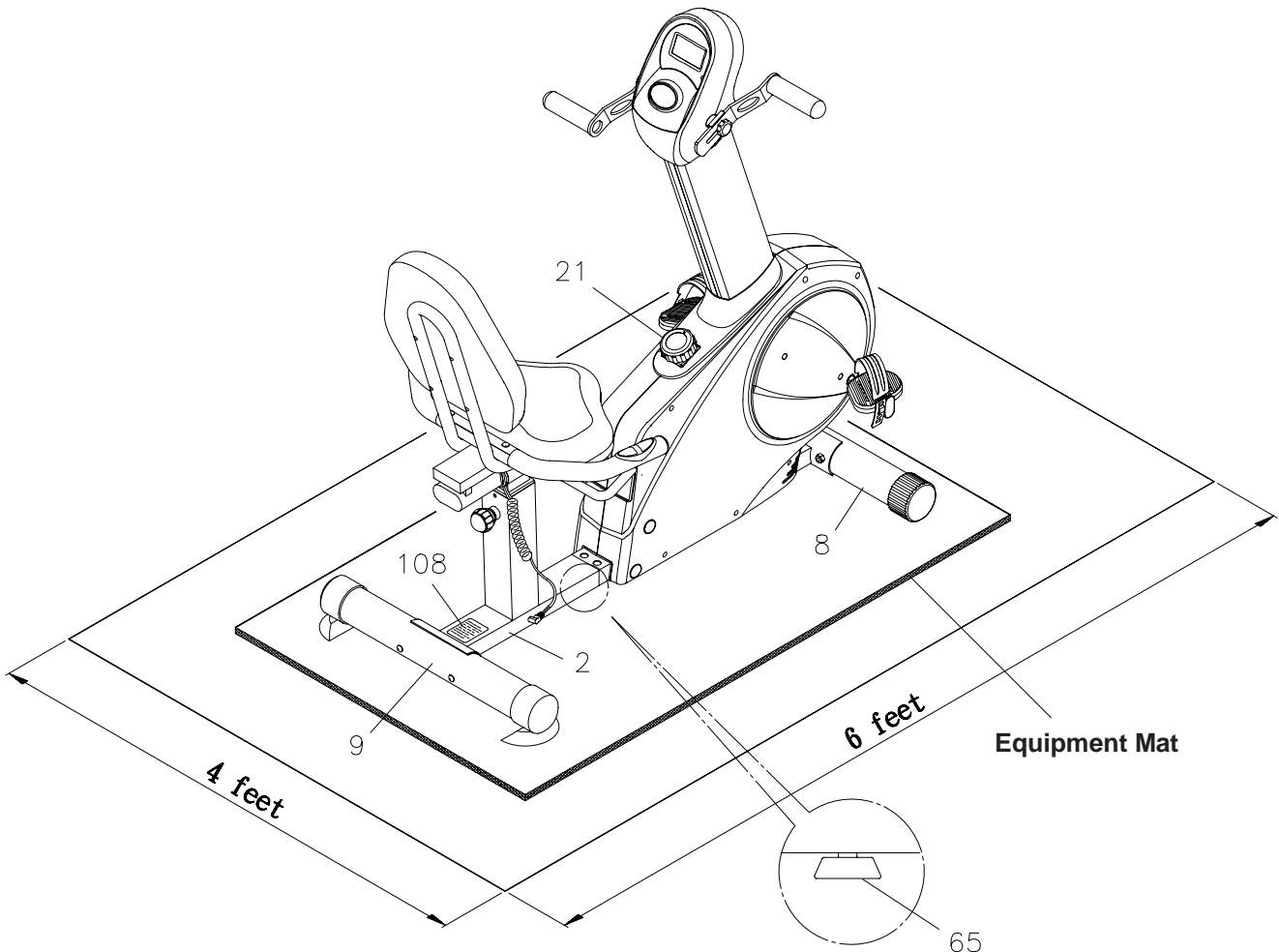

FUNCTION INSPECTION:

Visually inspect the **TOTAL BODY RECUMBENT BIKE** to verify that assembly is as shown in the above illustration. Check the function of the **TOTAL BODY RECUMBENT BIKE**. Turn the pedal and then handlebar slowly through one complete revolution to verify that the drive train functions properly. Adjust the **TENSION KNOB(21)** and verify that it functions properly.

CAUTION: Locate and read the **Warning Label(108)** on the **TOTAL BODY RECUMBENT BIKE**. Make sure that all users read the **Warning Label(108)**.

OPERATIONAL INSTRUCTIONS

NOTE: The **HANDLEBARS(51)** may be assembled in opposite directions or the same direction as shown in illustrations 1 and 2. Opposite directions as shown in illustration 1 is suggested for aerobic exercise.

ADJUST THE LENGTH OF THE ROTATING HANDLEBAR

Loosen the **ADJUSTMENT KNOBS(52)** and adjust the **HANDLEBARS(51)** to your ideal position. Tighten the knob to lock the handlebar in position. The **HANDLEBARS(51)** must adjusted to the same position on both sides.

CAUTION: When using the **ROTATING HANDLEBARS(51)** and **PEDALS(25, 27)** at the same time, take precautions to avoid hitting your knees with the **HANDLEBARS(51)**.

1. Adjust the **HANDLEBARS(51)** to the shortest position.
2. Exercise so that the **RIGHT HANDLEBAR(51)** is up when the right knee is up and the **LEFT HANDLEBAR(51)** is up when the left knee is up.

SEAT ADJUSTMENT

Proper seat adjustment is important.

1. **HORIZONTAL ADJUSTING:** Turn the **SEAT ADJUSTMENT LEVER(63)** counter-clockwise to loosen the **SEAT ASSEMBLY(36)**. Slide the **SEAT ASSEMBLY(36)** forward or backward to adjust the seat and tighten the **SEAT ADJUSTMENT LEVER(63)** clockwise after adjusting the seat to a new position. Refer to illustration 3.

NOTE: Please make sure to tighten the **SEAT ADJUSTMENT LEVER(63)** securely prior to use.

2. **HEIGHT ADJUSTING:** Hold the **BACK CUSHION(35)** as shown in illustration 4. Use other hand to Loosen and pull the **SPRING KNOB(64)**. Slide the seat up or down to adjust. Release the knob and make sure it is inserted into one of the adjustment holes in the **SEAT POST(3)**. Tighten the **SPRING KNOB(64)**.
3. Sit on the seat and place your feet on the pedals. You should be able to move through a complete pedal stroke without locking your knees or shifting your hips on the seat. The seat is too close to the pedals if you have more than a slight bend in your knees at the bottom of the pedal stroke. The seat is too far from the pedals if you have to completely straighten your knees at the bottom of the pedal stroke.
4. Sit on the seat and hold the handlebars. You should be able to move through a complete rotational stroke with arms slightly bent. If your arm is too straight or your upper body leans forward too much, you will need to adjust the seat closer to the handlebar. If your arm is bent too much you will need to adjust the seat farther away from the handlebar.

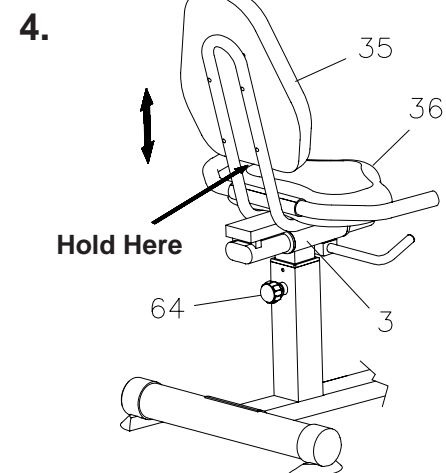
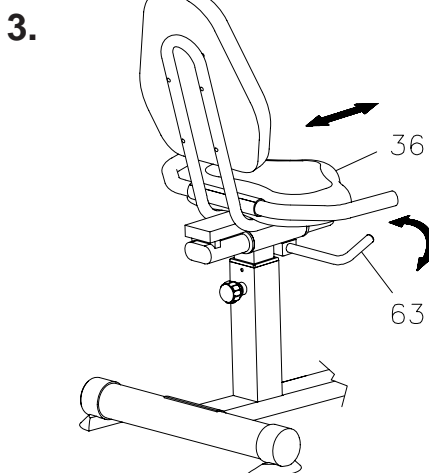
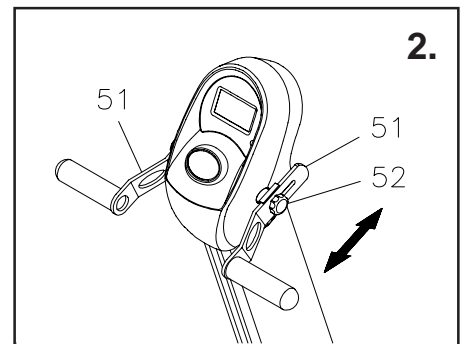
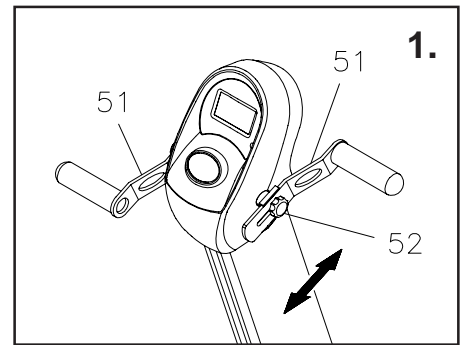

OPERATIONAL INSTRUCTIONS

LOAD ADJUSTMENT

To increase the load, turn the **TENSION KNOB(21)** clockwise. To decrease the load, turn the **TENSION KNOB(21)** counterclockwise. There are eight levels for the load adjustment.

NOTE: The load will increase as you pedal faster.

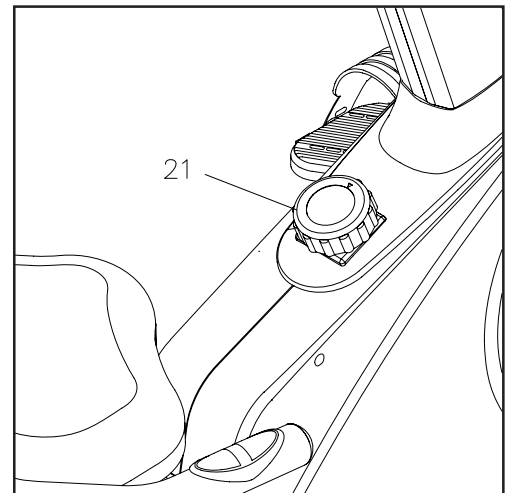

STORAGE

1. To store the **TOTAL BODY RECUMBENT BIKE** simply keep it in a clean dry place.
2. The **TOTAL BODY RECUMBENT BIKE** is approximately 49 5/8" long x 23 5/8" wide x 48 5/8" tall. These dimensions will vary. Please measure your **TOTAL BODY RECUMBENT BIKE** if exact dimensions are needed.
3. To move the **TOTAL BODY RECUMBENT BIKE**, lift the **REAR STABILIZER(9)** and use the **WHEELS(76)** on the **FRONT STABILIZER(8)**.
4. To avoid damage to the electronics, remove the batteries before storing the **TOTAL BODY RECUMBENT BIKE** for one year or more.

MAINTENANCE

The safety and integrity designed into the **TOTAL BODY RECUMBENT BIKE** can only be maintained when the **TOTAL BODY RECUMBENT BIKE** is regularly examined for damage and wear. Special attention should be given to the following:

1. Adjust the **TENSION KNOB(21)** and verify that the Magnetic System provides tension. The Magnetic System should provide many years of use.
2. Use a wrench to verify that the pedals are tightened securely. If tightening is required, remember that the left pedal has left hand threads and is tightened by turning counterclockwise.
3. Verify that the Warning Label is in place and easy to read. Call Stamina Products immediately (1-800-375-7520) for a replacement Warning Label if the Warning Label is missing or damaged.
4. It is the sole responsibility of the user/owner to ensure that regular maintenance is performed.
5. Worn or damaged components shall be replaced immediately or the **TOTAL BODY RECUMBENT BIKE** removed from service until repair is made.
6. Only Stamina Products supplied components shall be used to maintain/repair the **TOTAL BODY RECUMBENT BIKE**.
7. Keep your **TOTAL BODY RECUMBENT BIKE** clean by wiping with an absorbent cloth after use.

CONDITIONING GUIDELINES

How you begin your exercise program depends on your physical condition. If you have been inactive for several years, or are severely overweight, you must start slowly and increase your time on the **TOTAL BODY RECUMBENT BIKE** gradually: a few minutes per workout.

Initially, you may be able to exercise only for a few minutes in your target zone, however, your aerobic fitness will improve over the next six to eight weeks. Don't be discouraged if it takes longer. It's important to work at your own pace. Ultimately, you'll be able to exercise continuously for 30 minutes. The better your aerobic fitness, the harder you will have to work to stay in your target zone. Please remember these essentials:

- Have your doctor review your training and diet programs to advise you of a workout routine you should adopt.
- Begin your training program slowly with realistic goals that have been set by you and your doctor.
- Monitor your pulse frequently. Establish your target heart rate base on your age and condition.
- Set up your **TOTAL BODY RECUMBENT BIKE** on a flat, even surface at least 3 feet from walls and furniture.

EXERCISE INTENSITY

To maximize the benefits of exercising, it is important to exercise with the proper intensity. The proper intensity level can be found by using your heart rate as a guide. For effective aerobic exercise, your heart rate should be maintained at a level between 70% and 85% of your maximum heart rate as you exercise. This is known as your target zone. You can find your target zone in the table below. Target zones are listed for both unconditioned and conditioned persons according to age.

AGE	UNCONDITIONED TARGET ZONE (BEATS/MIN.)	CONDITIONED TARGET ZONE (BEATS/MIN.)
20	138~167	133~162
25	136~166	132~160
30	135~164	130~158
35	134~162	129~156
40	132~161	127~155
45	131~159	125~153
50	129~156	124~150
55	127~155	122~149
60	126~153	121~147
65	125~151	119~145
70	123~150	118~144
75	122~147	117~142
80	120~146	115~140
85	118~144	114~139

During the first few months of your exercise program, keep your heart rate near the low end of your target zone as you exercise. After a few months, your heart rate can be increased gradually until it is near the middle of your target zone as you exercise.

To measure your heart rate manually, stop exercising but continue moving your legs or walking around and place two fingers on your wrist. Take a six-second heartbeat count and multiply the results by 10 to find your heart rate. For example, if your six-second heartbeat count is 14, your heart rate is 140 beats per minute. (A six-second count is used because your heart rate will drop rapidly when you stop exercising.) Adjust the intensity of your exercise until your heart rate is at the proper level.

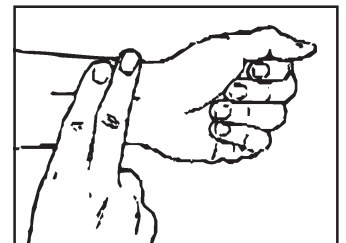

WARM-UP and COOL-DOWN

Warm-up The purpose of warming up is to prepare your body for exercise and to minimize injuries. Warm up for two to five minutes before strength-training or aerobic exercising. Perform activities that raise your heart rate and warm the working muscles. Activities may include brisk walking, jogging, jumping jacks, jump rope, and running in place

Stretching Stretching while your muscles are warm after a proper warm-up and again after your strength or aerobic training session is very important. Muscles stretch more easily at these times because of their elevated temperature, which greatly reduces the risk of injury. Stretches should be held for 15 to 30 seconds. Do not bounce.

Suggested Stretching Exercises

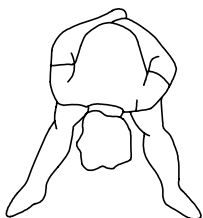

Lower Body Stretch

Place feet shoulder-width apart and lean forward. Keep this position for 30 seconds using the body as a natural weight to stretch the backs of the legs.

DO NOT BOUNCE!

When the pull on the back of the legs lessen, try a lower position gradually.



Floor Stretch

While sitting on the floor, open the legs as wide as possible. Stretch the upper body toward the knee on the right leg by using your arms to pull your chest to your thighs. Hold this stretch 10 to 30 seconds.

DO NOT BOUNCE!

Do this stretch 10 times. Repeat the stretch with the left leg.

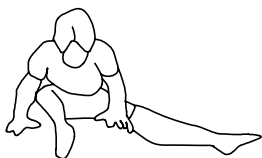

Bent Torso Pulls

While sitting on the floor, have legs apart one leg straight and one knee bent. Pull the chest down to touch the thigh on the leg that is bent and twist at the waist. Hold this position at least 10 seconds. Repeat 10 times on each side.

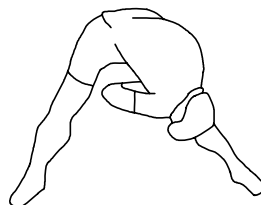
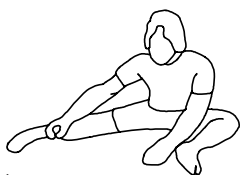

Bent Over Leg Stretch

Stand with feet shoulder-width apart and lean forward as illustrated. Using the arms, **gently** pull the upper body towards the right leg. Let the head hang down. **DO NOT BOUNCE!**

Hold the position a minimum of 10 seconds. Repeat pulling the upper body to the left leg. Do this stretch several times slowly.

Remember always to check with your physician before starting any exercise program.

Cool-Down The purpose of cooling down is to return the body to its normal, or near normal, resting state at the end of each exercise session. A proper cool-down slowly lowers your heart rate and allows blood to return to the heart. Your cool-down should include the stretches listed above and should be completed after each strength-training session.

PRODUCT PARTS DRAWING

FRONT

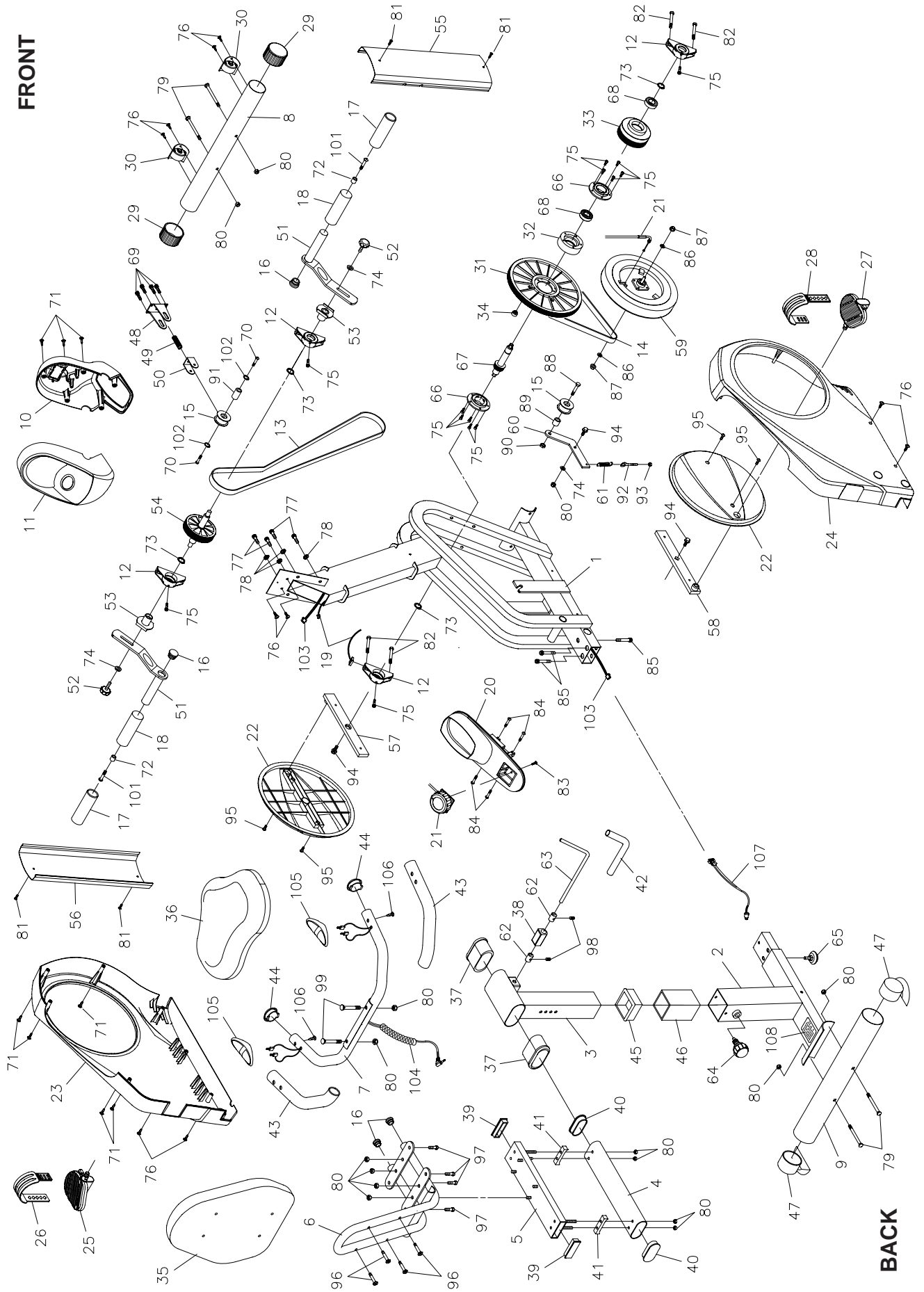

BACK

PARTS LIST

DIAGRAM#	PART NAME	QTY
1	Main Frame	1
2	Rear Frame	1
3	Seat Post	1
4	Sliding Tube	1
5	Seat Support Tube	1
6	Seat Frame	1
7	Handrail	1
8	Front Stabilizer	1
9	Rear Stabilizer	1
10	Back Meter Cover	1
11	Meter /w Front Cover	1
12	Bearing Housing	4
13	Long V-Ribbed Belt (73 inch)	1
14	V-Ribbed Belt (43 inch)	1
15	Idler Wheel	2
16	Round Plug (25mm)	4
17	Grip	2
18	Rotating Sleeve	2
19	Speed Sensor Wire	1
20	Top Cover	1
21	Tension Knob	1
22	Crank Cover	2
23	Left Cover	1
24	Right Cover	1
25	Left Pedal	1
26	Left Pedal Strap	1
27	Right Pedal	1
28	Right Pedal Strap	1
29	Round Endcap (76mm)	2
30	Moving Wheel	2
31	Pulley (250mm)	1
32	Connection Wheel	1
33	Small Pulley (100mm)	1
34	Magnet	1
35	Back Cushion	1
36	Seat	1
37	Oval Bushing	2
38	Adjustment Block	1
39	Rectangular Plug (30mm x 60mm)	2
40	Oval Plug (30mm 70mm)	2
41	Spacer	2
42	Fixing Bar Foam Grip	1
43	Handrail Foam Grip	2
44	Round Plug (32mm)	2
45	Hollow Cap	1
46	Bushing Sleeve	1
47	Stand Cap (76mm)	2
48	Idler Wheel Support Bracket	1
49	Pressing Spring	1
50	Idler Wheel Bracket	1
51	Handlebar	2
52	Adjustment Knob	2
53	Mounting Bracket	2
54	Upper Pulley (105mm)	1
55	Right AL Upright	1
56	Left AL Upright	1

PARTS LIST

DIAGRAM#	PART NAME	QTY
57	Left Crank	1
58	Right Crank	1
59	Magnetic System	1
60	Idler Arm	1
61	Tension Spring	1
62	D Shape Spacer	2
63	Seat Adjustment Lever	1
64	Spring Knob	1
65	Stand	1
66	Free Wheel	2
67	Axle	1
68	Bearing (6004Z)	2
69	Bolt, Hex Head (M6 x 1 x 12mm)	4
70	Bolt, Hex Head (M6 x 1 x 10mm)	2
71	Screw, Round Head (M4 x 20mm)	8
72	Handlebar Spacer	2
73	C Ring (M20)	4
74	Washer (M8)	3
75	Screw, Round (M5 x 0.8 x 15mm)	14
76	Screw, Round Head (M5 x 18mm)	10
77	Bolt, Hex Head (M8 x 1.25 x 15mm)	4
78	Lock Washer (M8)	4
79	Carriage Bolt (M8 x 1.25 x 85mm)	4
80	Nylock Nut (M8 x 1.25)	15
81	Screw, Flat Head (M5 x 0.8 x 25mm)	4
82	Bolt, Hex Head (M8 x 1.25 x 55mm)	4
83	Screw, Round Head (M5 x 0.8 x 15mm)	1
84	Bolt, Hex Head (M6 x 1 x 30mm)	4
85	Bolt, Socket Head (M8 x 1.25 x 50mm)	3
86	Washer (M10)	2
87	Flange Nut (M10 x 1.25)	2
88	Bolt, Hex Head (M10 x 1.5 x 45mm)	1
89	Idler Wheel Spacer	1
90	Nylock Nut (M10 x 1.5)	1
91	Wheel Shaft	1
92	Eye Bolt	1
93	Nylock Nut (M6 x 1)	1
94	Flange Bolt (M8 x 1.25 x 25mm)	3
95	Bolt, Hex Head (M6 x 1 x 10mm)	4
96	Bolt, Hex Head (M8 x 1.25 x 40mm)	4
97	Bolt, Hex Head (M8 x 1.25 x 15mm)	4
98	Set Screw (M6 x 1 x 15mm)	2
99	Carriage Bolt (M8 x 1.25 x 50mm)	2
101	Bolt, Hex Head (M6 x 1 x 25mm)	2
102	C Ring (M10)	2
103	Pulse Connection Wire	1
104	Pulse Sensor Wire	1
105	Pulse Sensor Plate	2
106	Screw, Round Head (M4 x 25mm)	2
107	Pulse Extension Wire	1
108	Warning Label	1
109	Allen Wrench (4mm)	1
110	Allen Wrench (6mm)	1
111	Combination Wrench (13mm and 15mm)	1
112	Manual	1

WARRANTY

Stamina Products, Inc. warrants that this product will be free from defects in materials and workmanship under normal use, service and proper operation for a period of one year on the parts and 5 years on the frame from the date of the original purchase from an authorized retailer. **THIS WARRANTY SHALL NOT APPLY TO ANY PRODUCT WHICH HAS BEEN SUBJECT TO COMMERCIAL USE, ABUSE, MISUSE, ALTERATION OF ANY TYPE OR CAUSE OR TO ANY DEFECT OR DAMAGE CAUSED BY REPAIR, REPLACEMENT, SUBSTITUTION OR USE WITH PARTS OTHER THAN PARTS PROVIDED BY STAMINA PRODUCTS, INC.** Commercial use includes use of the product in athletic clubs, health clubs, spas, gymnasiums, exercise facilities, and other public or semipublic facilities whether or not the product's use is in furtherance of a profit making enterprise, and all other use which is not for personal, family, or household purposes.

To implement this limited warranty, send a written notice stating your name, date, and place of purchase and a brief description of the defect along with your receipt to **Stamina Products, Inc. P.O. Box 1071, Springfield Missouri, USA, 65801-1071** or call us at **1 (800) 375-7520**. If the defect is covered under this limited warranty, you will be requested to return the product or part to us for free repair or replacement at our option. **NO ACTION FOR BREACH OF THIS LIMITED WARRANTY MAY BE COMMENCED MORE THAN ONE (1) YEAR AFTER THE DATE THE ALLEGED BREACH WAS OR SHOULD HAVE BEEN DISCOVERED. NO ACTION FOR BREACH OF ANY IMPLIED WARRANTY MAY BE COMMENCED MORE THAN ONE (1) YEAR AFTER DELIVERY OF THE PRODUCT TO THE PURCHASER.** This limited warranty is not transferable. **IF ANY PART OF THE PRODUCT IS NOT IN COMPLIANCE WITH THIS LIMITED WARRANTY OR ANY IMPLIED WARRANTY, THE REMEDY OF REPAIR OR REPLACEMENT IS THE EXCLUSIVE REMEDY AVAILABLE TO YOU.** In the event that the purchaser makes any claim under this limited warranty or any implied warranty, the Warrantor reserves the right to require the product to be returned for inspection, at the purchaser's expense, to the Warrantor's premises in Springfield, Missouri. Return of the enclosed warranty registration card is not required for warranty coverage, but is merely a way of establishing the date and place of purchase.

Stamina Products, Inc. **SHALL NOT BE LIABLE FOR THE LOSS OF USE OF ANY PRODUCT, LOSS OF TIME, INCONVENIENCE, COMMERCIAL LOSS OR ANY OTHER INDIRECT, CONSEQUENTIAL, SPECIAL OR INCIDENTAL DAMAGES DUE TO BREACH OF THE ABOVE WARRANTY OR ANY IMPLIED WARRANTY.**

This limited warranty is the only written or express warranty given by Stamina Products, Inc. This warranty gives you specific legal rights, and you may also have other legal rights which vary from state to state. **ANY OTHER RIGHT WHICH YOU MAY HAVE, INCLUDING ANY IMPLIED WARRANTY OR MERCHANTABILITY OR FITNESS FOR A PARTICULAR PURPOSE, IS LIMITED IN DURATION TO THE DURATION OF THIS WARRANTY.**

The laws in some jurisdictions restrict the rights of manufacturers and distributors of consumer goods to disclaim or limit implied warranties and consequential and incidental damages with respect thereto. If any such law is found to be applicable, the foregoing disclaimers and limitations of and on implied warranties and consequential and incidental damages with respect thereto shall be disregarded and shall be deemed not to have been made to the extent necessary to comply with such legal restriction.

NOTES

NOTES

